

► **FEATURED:** 2015 FRAME BUILDING EXPO EXHIBITORS

February 2015 • \$4.50

# Rural Builder®

The Business Management Magazine for Rural Contractors

[www.ruralbuilder.com](http://www.ruralbuilder.com)



TOP PRODUCTS  
OF 2014

p. 6

ECONOMIC FORECAST

# CAUTIOUSLY SUNNY

**+**  
**PLUS:**  
New Products  
at the Expo





# Strength in Post Frame

Since 1951, Plyco has stood by you and by their products. Plyco offers a complete line of entry doors that surpass building codes and customer expectations. At Plyco, we've become the leader by delivering the quality products you and your customers demand.

**Build Plyco Strong.**

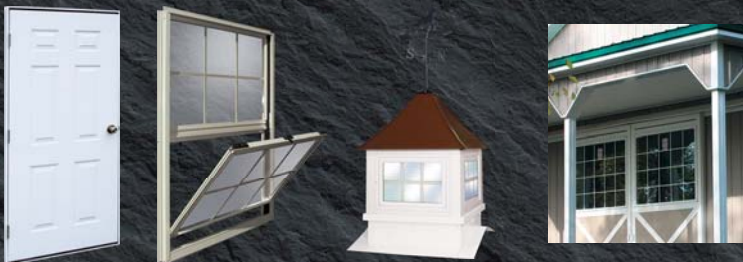
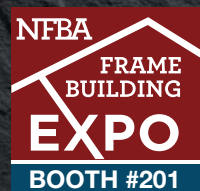

**PLYCO**  
CORPORATION

800.558.5895 • Fax: 800.257.5926 • [www.plyco.com](http://www.plyco.com) • Elkhart Lake, Wis.

Circle Reader Service #313

# Rural Builder

Volume 49 • Number 1

**Group Publisher**  
Jamie Wilkinson

**Publisher**  
David Davel

**Editorial Director**  
Debbie Bradley

**Editor**  
Sharon Thatcher - sharon.thatcher@fwcommunity.com  
715-445-2214, ext. 13644

**VP, Advertising Sales**  
Dave Davel

**Advertising Sales**  
Gary Reichert - gary.reichert@fwcommunity.com  
715-445-2214, ext. 13381

**Publication Design**  
Nicole MacMartin

**Production Coordinators**  
Kathy Budsberg - kathy.budsberg@fwcommunity.com  
715-445-2214, ext. 13309

**Patti Kirchner** - patti.kirchner@fwcommunity.com  
715-445-2214, ext. 13319

**Subscription Services**  
386-246-3452

**Office Phone**  
715-445-2214

**Office Fax**  
715-445-4087

**F+W, A CONTENT + ECOMMERCE COMPANY**

**Chairman & CEO**  
David Nussbaum

**CFO & COO**  
Jim Ogle

**President**  
David Blansfield

**President**  
Sara Domville

**CDO**  
Chad Phelps

**VP, eCommerce**  
Lucas Hilbert

**SVP, Mfg. & Production**  
Phil Graham

**VP, Communications**  
Stacie Berger

**SUBSCRIPTION SERVICE**  
Subscription inquiries, orders and address changes can be made at [constructionmagnet.com](http://constructionmagnet.com) (click on "Subscribe"). Or by mail: *Rural Builder*, P.O. Box 421751, Palm Coast, FL 32142-1751. Or call (866)805-1574, International (386)246-3452.

*Rural Builder* (ISSN: 0888-3025) Volume 49 Number 1 is published monthly, except January, April, June and November, by Krause Publications, a division of F+W Media, Inc., 700 E. State Street, Iola, WI 54990-0001. Periodical postage paid at Iola, Wis., and at additional mailing offices. Canadian Agreement Number: 40666675. POSTMASTER: send address changes to *Rural Builder*, Circulation Department, PO Box 420235, Palm Coast, FL 32142. Copyright 2015 by F+W. *Rural Builder* and its logo are registered trademarks. Other names and logos referred to or displayed in editorial or advertising content may be trademarked or copyright. *Rural Builder* assumes no responsibility for unsolicited materials sent to it. Publisher and advertisers are not liable for typographical errors that may appear in prices or descriptions in advertisements. Mailed free to rural contractors and their suppliers throughout North America. Others may subscribe: \$29.98 for 1 year, \$56.98 for 2 years, and \$79.98 for 3 years in the U.S.; \$39.98 for 1 year, \$74.98 for 2 years in Canada.



Top 10 Products [p.6]



Top eProducts [p.24]

## FEATURES [FEB 2015]

### IN FOCUS

Economic Forecast for 2015 / 12

### EXPO PREVIEW

Exhibitor profiles / 26

### TOP 10 PRODUCTS OF 2014

What readers requested most / 6

### TOP 3 E-GUIDE PRODUCTS

The best of 2014 / 24

### NEW PRODUCTS

Products making Expo debuts / 60

### [ON THE COVER]

A Forest Construction crew readies for roofing on a new barn near Stevens Point, Wisconsin. *Photo by Sharon Thatcher; Cover design by Nicole MacMartin*

## DEPARTMENTS

Editor's Page.....	4
Behind the Hammer.....	56
Advertiser Index.....	58
Supplier News.....	67
Industry News.....	55, 74
Classifieds.....	71
Money Talk.....	72
People in the News.....	74
Calendar of Events.....	74

## MARCH PREVIEW

<b>Overlooked liability issues</b>
<b>Metal Builder updates</b>
<b>Product Profile:</b> -metal building systems -door hardware
<b>Product Feature:</b> foundations



E-MAIL THE EDITOR AT  
[sharon.thatcher@fwcommunity.com](mailto:sharon.thatcher@fwcommunity.com)

Check our website at  
[www.ruralbuilder.com](http://www.ruralbuilder.com)

# TOUGH AS NAILS



## Ritchie®

A lot of folks have used the same Ritchie waterers for more than 30 years. They take abuse from the livestock, as well as the weather, and keep on performing. No waterers are tougher. Whatever your needs, we have the solution.

Let us hook you up.  
[www.RitchieFount.com](http://www.RitchieFount.com)



Fresh Water For Life™

Circle Reader Service #408

## editor's note

BY SHARON THATCHER



## One sexy beef barn

**BEEF FARMS SURE HAVE CHANGED SINCE I GREW UP ON ONE IN THE BUCKEYE STATE.** I don't see many living here in the Dairy State, so it was truly amazing to visit a Forest Construction site near Stevens Point, Wisconsin in January to find an extraordinary beef farm being built from the ground up by its 30-something owner.

During my visit, Joe Gille's crew at Forest—John, Andy, Chad, Mike, Levi and Adam—were preparing to put the roof on the first 108x325 foot barn, while back at the home office in Luxemburg, estimates were being discussed with the owner for a second barn the same size. Rather than grazed or contained on feed lots, the beef cattle will be enclosed in the state-of-art buildings, which the owner wanted to function well and “look sexy.”

The job site graces our cover this issue. Above are a few more views from my visit. **RB**



Sharon Thatcher,  
editor  
[sharon.thatcher@fwmedia.com](mailto:sharon.thatcher@fwmedia.com)  
800-726-9966, ext. 13644

WeatherXL™  
Crinkle Finish

# Performance you can see and feel

Unique textured perfection for the ages with WeatherXL™ Crinkle Finish, the new super-strength effects finish from Valspar.

## Color and texture

The unique texture redirects light for enhanced visual depth, promising a step-change improvement over flat-panels' appearance. The coating has been responsively designed, so its subtle shading mirrors the eye's natural horizontal motion. Let your eyes play over the surface, and delight in how it breaks up the light, creating an endless series of shifting, shimmering tones.

## Durability

Formulated with enhanced WeatherXL™ silicone polyester, this product delivers proven superior quality for outstanding performance. For all its beauty, it features an enduring weatherability to resist fading, scratching and chalking.

## For the "green" side of you

A texture coating that meets current solar reflectivity (SR) standards for LEED and Energy Star, which helps keep buildings cooler and energy costs down.

## A partner for the long haul.

Visit [www.valsparcoilextrusion.com/weatherxlcrinkle](http://www.valsparcoilextrusion.com/weatherxlcrinkle) or visit us at NFBA 2015 in booth #424 to learn more.

valspar  
if it matters, we're on it.®

Valspar Coil and Extrusion Coating Division  
888-306-2645  
coilhelp@valspar.com  
[valsparcoilextrusion.com/weatherxlcrinkle](http://valsparcoilextrusion.com/weatherxlcrinkle)

Circle Reader Service #484

# TOP 10 PRODUCTS OF 2014



In every issue of both *Rural Builder* and *Frame Building News* we have a section called “Product Profile”. There, we showcase products for rural builders. Information and photos are sent to us by suppliers and manufacturers for free exposure in this special section of the magazines.

When our readers take the time to circle our Reader Service Cards to request more information about a given product, those requests are routed to the manufacturers and suppliers for follow up.

But here at the offices of *Rural Builder* and *Frame Building News*, we also use that information. By looking at the numbers of requests, we can better understand the products you need to keep your business running smoothly. It keeps us on track to provide you the most useful information.

Then, at the end of the year we tally all the results to find the products that make up our Top 10 list.

On the next few pages, we share with you the results for 2014: the best of the best. Keep those requests coming in! **RB**



## ▲ PLYCO CORPORATION – COMMERCIAL-QUALITY WINDOWS AND DOORS



Plyco always scores high in our annual Top 10 count-down. In 2014 Plyco did it again.. We give nod to Plyco’s commercial windows and walk doors.

Windows: Plyco’s CTBW is constructed of 100 percent thermalized aluminum extrusions with ¾-inch thermo pane glazing. AATL (All Aluminum Trimline) windows, is an aluminum frame window specifically designed for the metal clad building industry. CVW (Commercial Vinyl Windows), is a commercial grade vinyl window constructed with a 2-inch master frame and multi-chambered PVC profiles with welded corners to increase strength and maintenance-free beauty. Plyco’s vinyl framed basement windows are specifically designed for masonry applications.

Doors: Like its windows, Plyco’s full line of walk doors meets today’s building codes in every category, from agricultural and out buildings to commercial fire- and wind-rated to residential. **Circle 100**



## ◀ CANNONBALL:HNP – FLAT TRACK HARDWARE SYSTEM



CannonBall:HNP’s new flat track and hardware system was introduced in the March issue of *Rural Builder*. The system is perfect for that historical barn door look with the same quality that CannonBall:HNP is known for.

With the option of the horseshoe or strap systems, which include all the hardware needed, the possibilities are endless. **Circle 101**

# FARM AND COMMERCIAL SLIDING DOOR SYSTEMS

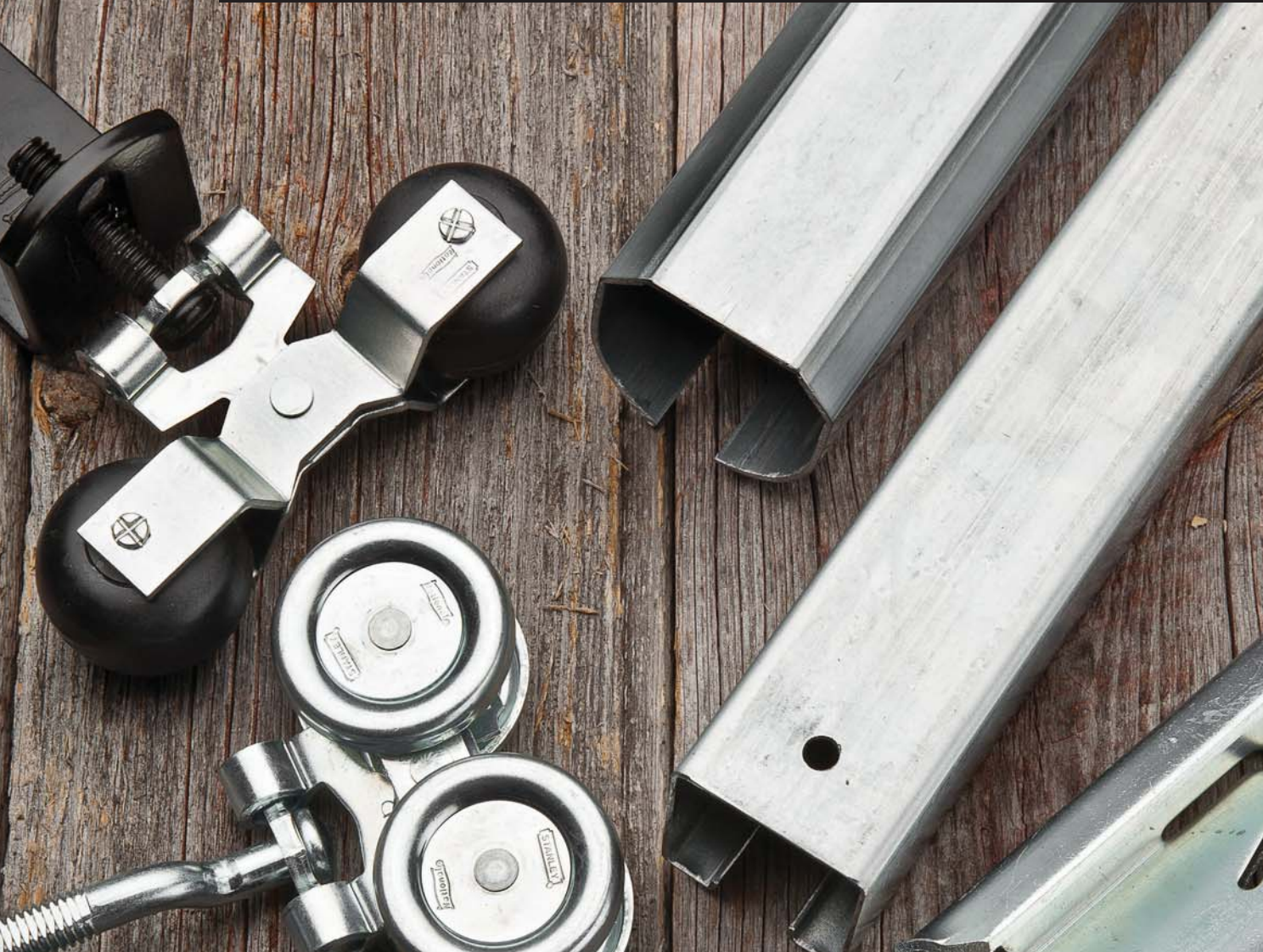

## Featuring TrackMaster™ Round Rail

- Tested for more than 225,000 feet of travel
- Unique design to keep rail from rolling away from building
- Available with loose mounted or welded brackets
- Hangers available with Delrin® or hardened steel wheels

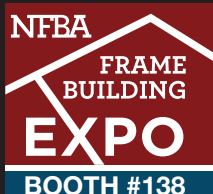

19095

Circle Reader Service #540

**National**  
Hardware™

800.346.9445 | [www.natman.com](http://www.natman.com)

BY RURAL BUILDER STAFF



◀ **DYNAMIC FASTENER – DF BRAND SELF-DRILLING SCREWS**



Featured in the May issue of *Rural Builder* was Dynamic's DF Brand of self-drilling screws.

D.F. brand self-drilling screws are used for stitching and sheet-to-structural applications. Clip screws require a low clearance head when fastening to steel or wood. Fasteners are available in stainless steel and with the Dyna-Coat 1,000 hour salt spray premium coating.

The D.F. Fenderhead line includes the #14 self-drilling T-5 fastener. Available at 1-1/2 to 8 inches long, the T-5 will fasten steel to structural steel from .250 to .625 inches total steel thickness. The 3/8-inch HWH

also comes with a large 5/8-inch O.D. washerface. Fenderheads are available with the Dyna-Coat 1,000 hour salt spray premium coating. **Circle 102**



◀ **MWI COMPONENTS – CUPOLAS**



Also high on the popularity charts for 2014 were cupolas from MWI Components.

Top 10 award-winning MWI-manufactured cupolas offer the perfect decoration for any post-frame project. MWI offers 24, 36, 48 and 66 inch choices in its four-sided design. The company also offers an eight-sided octagon design that stands 7 or 12 feet tall. In addition to the vast color selection, customers have the option of specifying their cupolas with louvers or windows. MWI Components is centrally located in Spencer, Iowa and services customers in the post-frame building industry with quality products all over North America. **Circle 103**

centrally located in Spencer, Iowa and services customers in the post-frame building industry with quality products all over North America. **Circle 103**



▲ **A.J. MANUFACTURING – WALK DOORS**



A.J. Manufacturing grabbed attention last February with its line of walk doors.

Steel frame, composite frame and aluminum frame doors are all 4-way universal with factory-standard low profile sill.

Recent innovations, including the SST – Stainless Steel Responder, FGx – Fiberglass door, Responder and Partner doors demonstrate A.J.'s commitment to the post-frame industry.

Custom sizing, painting and labeling all add value to the doors and are part of A.J.'s commitment to building ideas for post frame. **Circle 104**

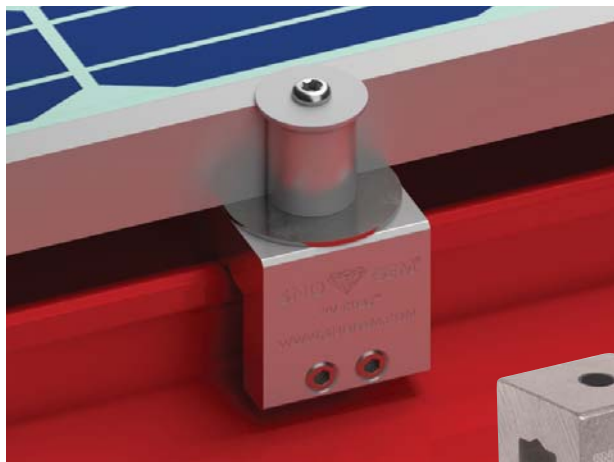

◀ **SNO GEM INC. – PV CUBE STANDING SEAM ATTACHMENT SYSTEM**



As standing seam roofing continues to grow in popularity, so does the need to securely attach things to it and Sno Gem continues to be an innovator. Introduced in the August issue of *Frame News* was the PV Cube attachment system.

Three points of attachment provide unparalleled strength to the PV Cube standing seam attachment system from Sno Gem Inc. The clamp-to-seam solar panel racking and mounting system has been designed to accommodate virtually any standing seam metal roof. It features Sno Gem's Silver Bullet set screws that feature a rounded bullet tip to maximize strength, but doesn't damage the paint finish or pierce the seam.

To assist installers with attachment to a variety of standing seam profiles, Sno Gem has designed the PV Cube, the PV Cube Wide, the PV Cube Mini and the PV Cube Zip. All are constructed of aircraft-grade aluminum extrusion and employ the patent-pending WaveLock technology. **Circle 105**



**BUILT FOR POST FRAME**

**THE INDUSTRY'S LEADING MANUFACTURER AND SUPPLIER OF POST FRAME BUILDING ACCESSORIES**

Since 1985 MWI Components has been manufacturing quality products for the Post Frame Industry, right here in Northwest Iowa.

**WE ARE YOUR ONE-STOP SHOP FOR ALL YOUR POST FRAME NEEDS**

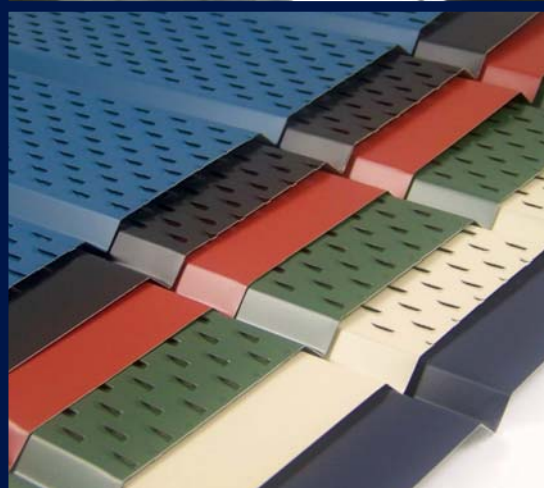

**COME SEE US AT BOOTH #225 AT THE NATIONAL FRAME BUILDING EXPO**

**FEBRUARY 18 - 20 IN LOUISVILLE, KENTUCKY**

• WE LOOK FORWARD TO VISITING WITH YOU •

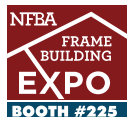

**MWI Components • [www.mwicomponents.com](http://www.mwicomponents.com)**

**1015 32nd Ave West • Spencer, Iowa 51301**

**Ph: 800-360-6467 - Ext 5 • FAX: 800-361-3452**



Circle Reader Service #308



## top products

BY RURAL BUILDER STAFF



### ▲ LEVI'S BUILDING COMPONENTS - TITEBOND, EMSEAL & FLOVENT



With a new name and renewed commitment to be a single-source for building components, Levi's Building Components took top honors in 2014 from our September issue of *Rural Builder* with its offerings of adhesives and sealants. For everything you need to lock nature's elements out of metal buildings check out Titebond (available in over 50 colors), EmSeal expanding foam, and the Flovent metal roofing ridge vent—tested to withstand driving rains with 100 mph winds. **Circle 106**



### GRABER POST - THERMAL 3HT



Grabber Post continues to expand its product offerings. Showcased in the June issue of *Frame Building News* was Thermal 3HT insulation.

Thermal 3HT is a vapor barrier, an air barrier, a radiant barrier, and an insulator all in one product! It is for commercial, agricultural, industrial or residential applications. This type of insulation actually allows thermostats to be set 2 to 4 degrees lower than buildings with conventional insulation products. With Thermal 3HT, your building is environmentally friendly, has stable performance, is water resistant, insect and mold resistant, and has great durability. **Circle 107**



### ▲ SNOBLOX-SNOJAX - ROOFCLAMP



Snow guard solutions put SnoBlox-Snojax at the top of our list in the May issue of *Rural Builder*.

SnoBlox-Snojax offers a variety of snow retention systems for most metal roof applications. Every product is professionally tested, American made and most ship the same day.

SnoBlox-Snojax has snow guard solutions with a variety of mounting options including adhesive attachment, mechanical fastening and non-penetrating clamp attachment. Products are backed with lifetime warranties. Free system design services are available. **Circle 108**

### PALRAM AMERICAS - PALIGHT TRIMBOARD SAND COLOR



Featured as a new product last August in *Rural Builder* was Palram Americas' addition of sand-colored Palight Trimboard to its lineup.

The fully pigmented trimboard is manufactured with color throughout the board, eliminating any need for touch-up painting after routing, mill-work or installation.

It is available in smooth/ smooth and also in a reversible option with wood grain/ smooth textures. The reversible option allows for reduced inventory requirements at distributor warehouses, at lumberyards, and even for contractors who hold small amounts of inventory. It is available with Palram's exclusive protective release film, ensuring the product stays clean from production through installation. **Circle 109**



# INSULATED METAL PANELS

by *McElroy Metal*

*Insulated Metal Panels* (IMP's) are formed by a continuously poured-in-place manufacturing process binding interior and exterior steel facings to a polyisocyanurate insulating foam core.

## *IMP Advantages:*

- Panelized vs Componentized Construction
- Ease of Installation / Reduced Labor
- Excellent Energy Efficiency
- R Value = 8 per inch
- No Thermal Breaks / Leaks
- Improved Climate Control
- Vertical or Horizontal Installation



**MESALINE**



**Metal Roof & Wall Panels**

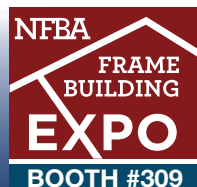

For more information:

**1-800-562-3576**

[info@mcelroymetal.com](mailto:info@mcelroymetal.com)  
[www.mcelroymetal.com](http://www.mcelroymetal.com)

Circle Reader Service #422

A partnership with



**GREEN SPAN PROFILES<sup>®</sup>**  
INSULATED PANEL TECHNOLOGIES

# 2015 Economic Forecast

Our panel of industry professionals are cautiously optimistic

**IT'S BEEN A LONG TIME COMING, BUT AFTER SLOGGING THROUGH SOME TOUGH TIMES FOLLOWING THE 2008 ECONOMIC CRISIS, BUILDERS ARE ONCE AGAIN SHOWING CAUTIOUS OPTIMISM.**

Light at the end of the tunnel? That seems an apt description for how construction professionals are viewing the year going forward in 2015.

*Rural Builder* pulled together a small informal survey to help gauge the mood of the rural construction industry. The graphic at right reveals how the results stacked up. **RB**

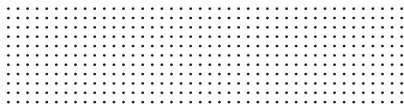

## SURVEY RESULTS

### EXPECTED CONTRACT VOLUME CHANGE 2015 VS. 2014

- Moderate increase expected: 43.9%
- Expect to stay about the same: 43.9%
- Significant increase expected: 8.6%
- Moderate decrease expected: 5.7%

### EMPLOYMENT OUTLOOK FOR 2015

- Likely to remain the same: 62.9%
- Expect to hire: 31.4%
- Expect to be reduce: 5.7%

### BACKLOG AS OF MID-DECEMBER 2014

- Contracts lined up through 2015: 14.3%
- Contracts lined up for 6 months: 25.7%
- Currently working on a project and expect to stay busy all year: 22.9%
- Working project to project but are optimistic: 22.9%
- Currently working on a project with nothing lined up: 5.7%
- Currently have no contracts: 8.6%

### LEVEL OF OPTIMISM ABOUT CONSTRUCTION

- Cautiously optimistic: 42.9%
- Neutral: 22.9%
- Very optimistic: 20%
- Somewhat pessimistic: 14.3%
- Very pessimistic: 0%

### AREAS OF GROWTH EXPECTED IN 2015

- Single-family housing: 48.6%
- Commercial building: 40%
- Multi-family housing: 11.4%
- Agricultural building: 20%
- Institutional building: 8.6%
- Manufacturing building: 14.3%
- Public works: 11.4%
- None of the above: 22.9%

### AREAS OF DECLINE EXPECTED IN 2015

- Agricultural building: 20%
- Single-family housing: 8.6%
- Multi-family housing: 5.6%
- Commercial building: 8.6%
- Institutional building: 2.9%
- Manufacturing building: 5.7%
- Public works: 14.3%
- None of the above: 51.4%

## Save Labor & Materials with TextraFINE® Post Frame Insulation

**Convenient** 93" wide rolls fill cavities between posts requiring no extra lumber to support the insulation. (Other standard sizes available.)

**Fast** Excellent tensile strength and recovery for a friction fit and quick and easy installation.

**Resilient** Rigid insulation holds its shape and won't settle over time.

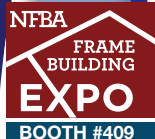

Call 800-837-2626 for a quote today!  
[www.AncoProductsInc.com](http://www.AncoProductsInc.com)



# DYNAMIC FASTENER



*Everything for the Metal Builder and Roofer*

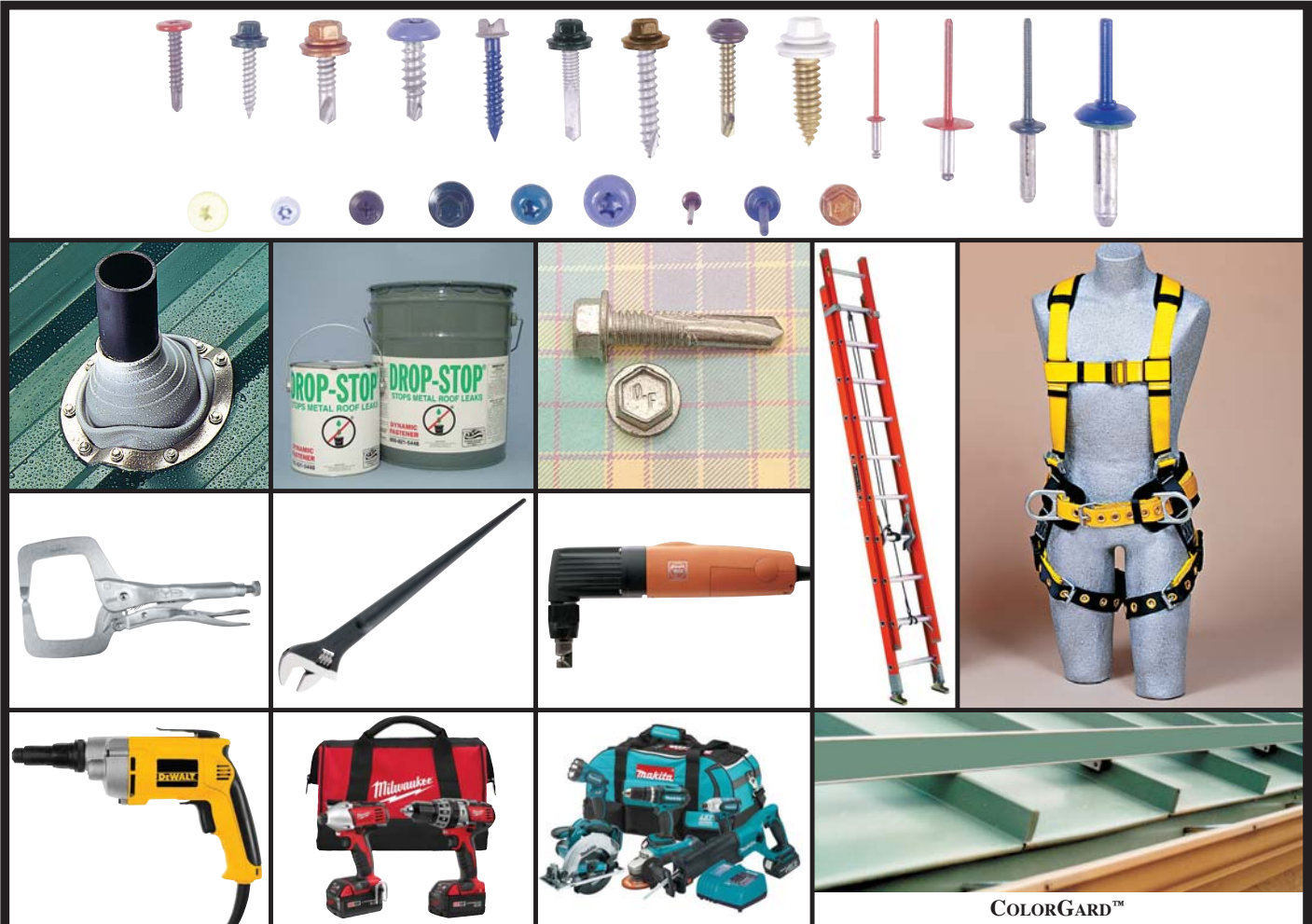

**FREE** 132 Page Full Color Tool & Fastener Hand Guide provides prices, engineering data & details product offering.

**DYNAMIC FASTENER** is specifically geared to handle the needs of the Metal Building Contractor. We provide in-house custom color painting of screws and rivets with just a one or two day (days, *NOT* weeks) lead time. **THOUSANDS** of power tools are stocked and sold at the lowest prices. Highest quality, top name brand fasteners are stocked and sold at the lowest prices. Same day shipment on orders received by 4:00 p.m. CST. We are a supplier to the largest metal building manufacturers.

We want to be **YOUR** source for screws, anchors, flashings, colorgard, safety equipment, hand tools, power tools and accessories.

**7 warehouses to serve your construction needs for tools and fasteners**

(MAIN OFFICE)

Kansas City • Chicago • Houston • Las Vegas • Memphis • St. Louis • St. Paul

**CALL 800-821-5448 or FAX 800-844-1199**

Call for your Free Full Color 132 Pg. Hand Guide. Better yet, call us for your next tool or fastener requirement. Discover for yourself why your peers enjoy doing business with our company!

# Rural builders & suppliers weigh in

Who better to know what the mood is like out in the field than the guys who work there—the builders and their suppliers. So we asked a few of them from across the country to share their outlooks.

## OPPORTUNITY

### Director of Business Development

BlueLinX Corporation is a leading distributor of building products in North America and we have an exciting **Agricultural Business Development** opportunity. We are seeking someone to manage all aspects of sales for our Agricultural business segment.

**Job Description:**

- Drive sales force effectiveness and key productivity initiatives
- Work with external suppliers and internal product management team to build customer relationships
- Manage inventory levels, increase product penetration and mix
- Atlanta Based – Significant travel required
- Excellent Benefits

Contact **Chellany Glover** to learn more about this and other career opportunities in sales, product management, supply chain, logistics and distribution. Send inquires to **Chellany.Glover@BlueLinXCo.com**.

BlueLinX Corporation is an Equal Opportunity Employer.



**888-647-BLUE**  
www.BlueLinXCo.com



Circle Reader Service #276

### DAVID WILLIAMS,

DAVID WILLIAMS CONSTRUCTION, HALFWAY, OREGON

**Outlook:** “2014 was terrific and we are booked into 2015, that hasn’t happened in a long time.

“I am the true rural builder. I live in a rural community. Our town has a population base of about 225, and we serve a population base of about 3,000 in this region. There are about eight general contractors around here that serve the farming, ranching, retirees/vacationers that have homes here. Everybody is fully booked. Mine is primarily high-end residential, stick frame. We do some timber frame, but the majority is stick built.

“Despite what you hear, the current administration has stabilized the economy. Fuel prices have declined dramatically because we’re producing more oil now in this country. Job numbers are up as people are feeling more confident.

“In this region, cattle prices affect the local economy significantly and beef prices are up. My neighbors are earning twice as much in the last two years as what they were earning the last 7, 8, 9 years. When you are doubling your income from your cattle herd that gives you a lot of spending money. So that has made a significant difference at least in Idaho and Oregon.”

**Material prices:** “Right now timber prices seem to be stable, at least in this region, that’s partly because we’re harvesting timber in the northwest, with massive amounts that are being exported as raw lumber to China. That has a lot of people concerned here that we’re shipping so much of our raw materials out of here when it should be engineered with some standards so that we get some value added. A lot of timber is being harvested off of someone’s land and essentially just given away.

“Timber prices I would like to think for the next six months are going to remain stable. But, there’s timber and then there’s engineered products like OSB and plywood products that can be very volatile. We had a big plywood mill, I was told it collapsed in a windstorm in Oregon and I got the last of a particular product I needed for the project we were on. Fortunately I got what was left in about a 250 mile radius.”

**Material supply:** “I have no real concerns. What I’ve learned: I do not intend to know the price of materials until I get a firm quote. Most contractors who have been in this business very long, he learns that by the time you price out a project, and you start a project three months later it can change.

**Advice to younger contractors:** “What I did years ago, I got involved in doing some government work through the U.S.



The market for hobby sheds is expected to remain strong. This one went up last fall near Merrill, Wisconsin with the help of the crew from Wick builder Willie Kimmons. *Rural Builder photo*

Forest Service. I recommend that anybody in rural areas try to diversify through a tie-in with a government agency. There's a government program called HUBZone for under-utilized business zones. It's a program that helps rural businesses connect with government agencies and their contracts. That was a tremendous help for me back in the '90s, because one project led to another, another and another."

**RICK ANDERSON,**  
ANDERSON CONSTRUCTION, STERLING, ILLINOIS

**Outlook:** "2014 was a little above average. New commercial projects in 2014 helped make it a better year.

"We're starting [2015] with a backlog. I'll have probably five buildings going into the year, and maybe more, as well as some odds and ends (repair work, going back and finishing off).

"The country suburban market (hobby sheds) I think are coming back to where they were pre-2008."

**Slow-down in ag construction:** "We did the Peoria farm show [in early December]. That is always a good show for finding out what the farmers are thinking for the next year, and it wasn't very good. A couple said they were thinking about building but not right now, maybe next year. I think I got two definite leads for people who are expecting to build next year, and normally we have more than that.

"So, I don't think [2015] will be as good ... I just don't see the interest from farmers. The farm work was down [in 2014] and I'm expecting it to be down again [in 2015]. It's a combination of lower tax credits and low commodity prices. There might be some live-stock buildings.

"The farming was just outstanding for four or five years and that kept us going. At one time we were doing 1/3 ag, 1/3 commercial, 1/3 suburban hobby sheds—those were always the main ones. Since 2008, the suburban hobby sheds have been way down. And the commercial, until [2014], it was way down. With commercial, right now

we're working on a banquet center that's a big project, we'll be finishing that up this winter. And we also had an oil station, and another oil company that we're working with for a future job."

**Material prices:** "I have no real concerns, not right now. We did get a little increase in labor, basically with insurance. Lumber went up a little bit [in 2014], but it wasn't huge."

**JASON BLENKER,**  
BLENKER COMPANIES (CONSTRUCTION SERVICE AND SUPPLY),  
AMHERST, WISCONSIN

**Market Strengths:** "Multi family was strong [in 2014] and single family is starting to see some improvement. We've got work booked into 2015, both multi family and single family, and I think single family is going to continue to improve based on the fact that the government is trying to clean up the lending situation."

**Lending:** "It's not that there isn't money available, it's just getting qualified, [the banks are] pretty tight on their qualifications. Interest rates are certainly low enough. In talking with consumers in the process of getting a loan the paperwork has gotten unbearable. Trying to address that, getting that cleared up is moving things forward a bit."

**Commercial:** "Commercial has been improving. It is getting better."

**Material prices:** "Drywall is going up. Lumber has been stable. I don't see any major increases. I think you're going to see the standard 3 percent to 5 percent increase, but that's not uncommon going into a new year."

**WAYNE TROYER,**  
PAINT VALLEY EQUIPMENT/ACU-FORM, MILLERSBURG, OHIO

Paint Valley Equipment sells after-market parts for heavy equipment and its Acu-Form division sells in-house roll forming equipment.

BY SHARON THATCHER

**Outlook:** “It looks very busy for us. Gangbusters. It was busy in 2013. The first of November 2014 it started really picking up again. And the way we’re going right now (late November), we’re already booked into April.

**Material prices:** “Steel prices have been fairly stable.”

**Concerns:** None. “Not the way it’s been going right now.”

**SAM TARTER,**

SJ TARTER, REAL ESTATE AND CONSTRUCTION,  
RUSSELL SPRINGS, KENTUCKY

**The past year:** “2014 was a pretty good year. Rural housing did well—vacation homes. Vacationing is a big industry in this area (Lake Cumberland region).

**Outlook:** “I’ve been seeing some new building and a lot of remodeling and a lot of additions.

“I think it will be a good year, as long as gas prices stay down. The only negative I see is that higher income homes are not selling. Most sales are \$200,000 and under. The market for higher-end homes was oversaturated.

“Bank loans are starting to loosen up. Tightening up the loan regulations was a good thing in the long run. They weeded those people out who really didn’t qualify and

couldn’t make the payments. It took a couple of years for that to happen.”

**The housing correction:** Tarter started in the business as a contractor in the early 1980s and said he saw the housing bubble starting to pop before it splattered. “The real estate appraisers were over-appraising properties. People were paying too much for a lot. Anybody can be a private mortgage broker, and they were on every corner.

“I prepared [for the downturn] and I’ve had a good past four years,” he said. “I sold everything out [from the construction business], now I just sub everything. I build only spec homes and I sell them. The subs get in and get it done.”

Today, Tarter picks up real estate for pennies on the dollar on the steps of the county courthouse. He is investing in the future, but he’s not expecting the economy to come roaring back any time soon to pre-2008 levels.

“People my age, I’m 65, heard about the Great Depression and how long it took to recover, and because of that they were concerned that [the latest] could be a long-term recession and they were afraid to spend money. Also I think a lot of people said, ‘Hey, I don’t need to spend this money. I don’t need to keep up with my next door neighbor, because he went broke.’”

# Take a look, check us out!

A.J. Manufacturing has the door and window for every building.

- Stainless Steel Door
- FGx—Fiberglass Door
- Partner Door™
- Responder Door™
- 3100, 5100 & 7100 Rollformed Doors
- 4-Way Universal Doors
- Dedicated Inswing Doors
- Aluminum Windows
- Vinyl Windows
- A.J. Exclusive Patented EZ-V™ Vinyl Window Trim System



Distributors of:



Come visit us at **Booth #530**  
2015 Frame Building Expo in Louisville, KY

**Building Ideas**

A.J. Manufacturing, Inc.  
1217 Oak Street  
Bloomer, WI 54724  
800.328.4448 [www.ajdoor.com](http://www.ajdoor.com)

Circle Reader Service #334

**MIKE MOMB,**  
HANSEN POLE BUILDINGS, BROWNS VALLEY,  
MINNESOTA

**Outlook:** "I think it's going to be a good year and probably for several years. There's a pent up demand. The inquiry levels for us never slowed down. As far as people buying, [that dropped], but as far as people contacting us for information, pricing, there was never even a hiccup."

**Challenges:** "The challenge seems to be finding people that are competent to get things built."

"What we're doing is kits designed for people to do it themselves. The average do-it-yourselfer does great because they read directions. Ninety percent of the technical support we do is where people have hired a builder and the builder doesn't look at the plans and doesn't get instructions, they just wing things together until, whoops, it doesn't work."

"I kind of liken it back to when I was a builder in the '90s and I had construction crews out there. I had some crews that would spend all day long trying to solve something that a five-minute phone call would solve. They just blender through things and that only makes things worse."

**Opportunities:** "At one time, a decade ago, I would have said 75 percent to 85 percent [of kit buyers] built their own, now it's like 45 percent to 50 percent, which surprises me given that the economy has been challenging for the last five or six years. You would expect that more people would be doing their own. My wife and I have talked back and forth about this. She has twin sons who are in their early 30s who would be totally capable of putting up their own building but they would hire someone to do it. They make enough money they can say, 'I want to spend my time fishing and hunting. I don't want to put up my own building.'"

"[At Hansen] when things went into the tank in 2008, we got rid of people we could automate instead. We had almost two dozen then and now we're under 10 full time people and yet ... we're doing far more work with far less people. It was actually painful going through it, but in the long haul we came through the other side in better shape, much better able to handle a huge volume of business with a lot fewer people."

"We spent money on IT people, improving our website. We built a proprietary pricing program that actually engineers the building in the background and can virtually price any building in the country."

**Supplies:** "It seems that things cooling off in China has added some stability to the market. Before, [China was] consuming so

much, it wasn't what was happening in the States that was driving things, it was whatever the Chinese did. It is a global economy whether we want to admit it or not."

"Oil prices are stable so that's a huge driver, too. The price of oil goes over \$100 per barrel and everything goes up because everything gets shipped. **RB**"

## Build with Confidence Build with Wick Buildings

Wick Buildings has been helping farmers, families and businesses by providing long-lasting, low-maintenance buildings since 1954.

Buildings with quality and value...and no compromises. Join our team!

**800-356-9682**  
**WickBuildings.com**







Agriculture ■ Suburban ■ Equestrian ■ Commercial

Stop by our booth, #318, at the NFBA Frame Building Expo and enter to win a free iPad Air 2!





Circle Reader Service #511



The foundation is laid for a good year, just as this concrete crew lays the foundation for a large storage shed. *Rural Builder photo*

## What construction economists are saying

To help make sense of all the government and industry statistics that are generated, *Rural Builder* asked for the input of economists Kenneth Simonson, Associated General Contractors of America, and Anirban Basu, Chief Economist, Associated Builders and Contractors. They offer a look at how 2014 went, and the economic indicators for 2015.

**KENNETH SIMONSON,**  
CHIEF ECONOMIST, ASSOCIATED GENERAL CONTRACTORS OF AMERICA

**Outlook:** “Overall things are looking positive ... I would say the industry is continuing to experience growth but it is moderate, not really rapid and it’s quite uneven.

“In general, multi-family housing construction has been an extremely hot market and looks to continue very strong in 2015. Single-family home building has also been growing but generally falling short of the expectations of home builders and housing analysts. And then on the private nonresidential side, there’s been really strong growth in manufacturing and warehouse construction and in such niches as railroads, hotels and some parts of power (high line construction) but the big retail and office construction categories have remained rather weak.

**Regional trends:**

“Overall the picture is bright but it does have some dark spots. About three-quarters of the states are adding jobs on a year-over-year basis on any one month but the particular states on that list do change from month to month.

“There are some consistent winners on that list, namely North Dakota thanks largely to the Williston Basin oil. Also oil-related states like Louisiana, Oklahoma, and Texas, all doing very well.

“California has been adding jobs at a strong rate.

“Other states that had been doing well earlier have

OVERALL THE PICTURE IS POSITIVE...

# 1900-SERIES ENTRY DOORS

SNEAK PEEK  
*Coming Soon!*

Come see for yourself!

**FEB. 18-20**

NFBA  
FRAME  
BUILDING  
**EXPO**

**BOOTH #143**

*Louisville, KY*

- Professional looks and field adaptability for any building project
- 24-gauge steel skin, 16-gauge steel jamb and Grade 40 security
- Wide variety of panel embossment options

Recommended Project Use

	<b>Agriculture</b>	<input checked="" type="checkbox"/>
	<b>Commercial</b>	<input checked="" type="checkbox"/>
	<b>Metal</b>	<input checked="" type="checkbox"/>

**GET READY FOR OUR NEWEST, MOST VERSATILE DOOR**



800-766-2825 • Beloit, WI  
[www.cnbhnp.com](http://www.cnbhnp.com)



Circle Reader Service #386

# SNO GEM®

Snow Retention, Solar Panel & Roof Accessory Attachments

S  
N  
O  
W



S  
O  
L  
A  
R

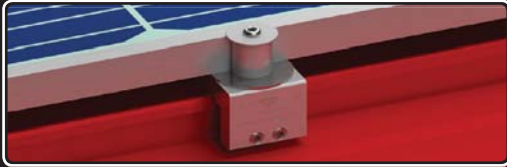

R  
O  
O  
F



## ACCESSORIES



All Clamp Systems Utilize Our Patent-Pending WaveLock™ Technology



www.snogem.com | info@snogem.com | (888) SNO-GEMS

Circle Reader Service #482

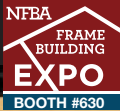

10 WoodTiteHL™  
ATLAS HIGH-LOW FASTENER

### Type-17 Point

Helps to penetrate metal more quickly!

High Major Threads with Low Minor Threads

Ensures Faster Drill Times!

### Aster Threads

Innovative hybrid threads cut through hard woods!



Circle Reader Service #328

## in focus

BY SHARON THATCHER

dropped back: Arizona and West Virginia [there has been some oil and gas activity in the northwestern edge of West Virginia, but not enough to offset the drop in demand for coal and coal-related construction activity].

“A few other states have remained lackluster throughout, such as New Jersey [still recovering from Hurricane Sandy while residents migrate from suburban areas to more urban areas outside the state] and New Mexico [dependent on military bases and laboratories that have been affected by federal spending freezes].”

**Concerns:** “Most general contractors expect 2015 to be a good year. ...I would say their biggest concern right now is not in finding work, but finding the workers to do it. The AGC sent out a survey in September that over 1,000 member contractors answered. Eighty-three percent of those companies had trouble filling one or another craft positions and 61 percent said they were having trouble filling professional positions, notably project managers and supervisors ... The bigger worry will be labor cost as contractors scramble to bring in the skilled labor they need. They’re going to be paying higher wages or bonuses to sign on, and a per diem for workers to travel.”

**The ag market:** “The AGC doesn’t cover the ag market in particular but the dollar has really strengthened a lot against the Euro and many other currencies in the last few months and that is generally bad news for farmers who rely on exports for many of their products, whether grain or corn or meat products, so I do think that will be a problem for farmers.

“Farmers use a lot of fuel so the drop in fuel costs, diesel fuel, propane or natural gas they use for drying crops, that will be quite helpful, but on net I think they’re going to be a lot more cautious about construction than they’ve been in the past few months.”

**Material prices:** “That’s a mixed picture but largely good news because the drop in diesel prices affects construction in a lot of ways. Contractors buy diesel for their trucks and other equipment, it affects fuel costs for delivery of materials ... there’s an awful lot of what goes into a construction project that requires fuel in some form or another ... so the drop in oil prices pays a lot of dividends for construction.

“Copper prices have also dropped very dramatically from the record they set four years ago. Steel prices have come down from their peak four years ago. Gypsum wall-board is continuing to go up. Lumber prices are always volatile but they’ve been on the upside.

“On net, though ... looking across 2015 I think material costs will generally be very close to where they have been.”

**ANIRBAN BASU,**  
CHIEF ECONOMIST, ASSOCIATED BUILDERS AND CONTRACTORS

**Outlook:** “ABC forecasts nonresidential construction spending will expand by roughly 7.5 percent [in 2015]. The segments that will experience the largest

# Code Slowing You Down?

The Uplift Solution is

## Simpler, Quicker, and Stronger



# UPLIFT PLATE™

## Post Foundation Anchor System

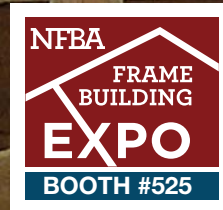

Advantages of **UPLIFT PLATE** vs. traditional rebar:

Over  
**300% MORE**  
Holding Power

**100% Right Choice!**



Over  
**50% LESS**  
Installation Time

- Low cost
- Easily applied in the field
- Ready to install
- Just hammer it on & done!
- Regular or hot dipped galvanized available
- Hot dipped galvanized plate is IBC approved 
- Does not expose the center of the post to the elements
- Meets or exceeds post uplift code requirements
- Made in the USA

(877) 897-7020

**LEVI'S™**  
BUILDING COMPONENTS

[www.levisbuildingcomponents.com](http://www.levisbuildingcomponents.com)  
Circle Reader Service #392

# Battling Condensation

Determining the Best Method of Control

BY MARK MULLINS, FABRAL



**AS SUPPLIERS AND INSTALLERS OF METAL ROOFING, WE HAVE ALL LIKELY DEALT WITH THE ISSUE OF CONDENSATION.**

There are several control methods available so the first consideration must be towards looking at the building construction to then determine the best method of controlling con-

densation. It's crucial to have conversations with customers and end users about condensation. The condensation control measures can, and most likely will, affect cost, so owners must be in the loop and fully educated as to their options. It's always best to educate the customer so they can make an informed decision about the next course of action.

This education starts with understanding the source of the issue. Condensation is caused when warm moist air inside a structure comes in contact with the cooler under side of the metal. The metal does not "sweat" – moisture must be introduced from another source, such as cooking or showering in residential projects. In post-frame structure, moisture stems from outdoor humidity, damp ground or animals.

When working with metal, three weapons are traditionally deployed in the battle against condensation: ventilation, insulation and vapor barriers. Venting removes the warmer moist air from the structure but requires open air flow from eave to ridge for this method to work properly. Insulation is used to keep attic space as close to the outside air temperature as possible but is only applicable to heated and cooled structures with an attic, such as a home. Vapor barriers prevent moist air from getting to the back of the metal panels but again are typically used only on projects with a solid deck such as a home.

This of course begs the question of what to do with open framed structures that typically have no attic space to vent or a solid deck to apply a vapor barrier. In this case, insulation blankets can be used between the purlins and the metal roof panels, but there are other alternatives to this available in the market. Condensation control products can be applied to the back of the metal panels during the fabrication process. It is always best to check with the panel manufacturer and inquire about what type of products they offer to help you effectively wage your battle against condensation.

For more information on condensation options e-mail questions to: [Fabral.com/askMark](mailto:Fabral.com/askMark).

## in focus

BY SHARON THATCHER

growth in construction spending in 2015 include power (e.g. natural gas-related construction), lodging (leisure and business spending), office space (professional services employment creation) and manufacturing (rebounding industrial production).

"The public sector will see far more sluggish growth in construction spending, however this fits a multi-year pattern with private nonresidential spending exceeding public nonresidential spending by 28 percent in 2014, up from 15.6 percent in 2013.

"Taking into account current economic momentum, especially in the form of employment growth, ongoing accommodative monetary policy and increased growth in consumer spending, further stoked by falling gasoline prices, 2015 should be a decent one for the U.S. economy. Contractors should continue to experience a lengthening backlog and the industry should continue to see increases in nonresidential construction spending and employment growth."

**Regional trends:** "Areas that have concentrations of industrial production and technology firms will lead the pack in 2015. These areas will also generate the most construction opportunities per capita going forward.

"There are always issues, of course, including compensation costs that will rise more quickly per worker than in years past. This will be particularly apparent in areas like Louisiana and Northern California, places that have experienced significant economic growth recently."

**Concerns:** "While the industry has seen a more robust recovery over the past year, the industry has still not fully recovered along many dimensions, including in total spending, employment and profit margins."

**Material prices:** "While material price inflation has been suppressed, it may accelerate in 2015. [In 2014] prices were suppressed due to a combination of factors, such as softer growth in most of Europe and Asia, rising energy production here in the U.S., and a stronger dollar. Some of these factors might not be as prominent [in 2015], so the stage could be set for price increases close to 3 percent.

"The sharp drop in oil and related commodity prices render those the most likely to experience [increases] in 2015."

**General mood of contractors:** "Contractors are generally upbeat regarding [the 2015] economic outlook. In fact, contractors have not expressed this level of optimism since the pre-recession period regarding demand for construction services. However, many are unnerved by expanding skills shortages and are nervous about winning work that they will not be able to complete on time or on budget because of a lack of personnel or available subcontractors." **RB**

# THERE'S A REASON WHY MORE CONTRACTORS LOOK TO FABRAL.



GRANDRIB 3® PLUS—THE BEST

GRANDRIB 3®—THE BETTER

NEW! TRUSTIRIB™—THE GOOD

That's because we help you perform at your very best.

As the premier supplier of quality metal roofing and wall panels, **Fabral offers solutions for any installation type and budget**—from our top tier GRANDRIB 3® series to our new, economical TRUSTIRIB™ line. Standing behind our products are some of the industry's strongest warranties, matched by the expertise and knowledge of a customer care team committed to supporting you at every step through project consultation, training and technical support.

Ready to take your business from good to best? Better talk to Fabral.

Visit us at the Frame Building Expo, booth 539 on February 18-20

**FABRAL**  
METAL WALL AND ROOF SYSTEMS

800-477-2741  
Fabral.com



POST FRAME | RESIDENTIAL | LIGHT COMMERCIAL | ARCHITECTURAL

Circle Reader Service #393

# TOP e-PRODUCTS OF 2014



Requests for more information from our online e-Guides determine the winners of our annual Top eProducts. In 2014 the most requests were received for equestrian planning and construction from Wick Buildings; Retro-Pan insulation system from TVM Building Products; and the Master One-Steppers fastener from Leland Industries. **RB**



## LELAND INDUSTRIES - MASTER ONE-STEPPERS

Master One-Steppers, the only one-step fastener for fiberglass or PVC panels, are designed for attaching panels that exhibit thermal expansion to wood frame structures. The revolutionary patented design self-drills an expansion hole, automatically centers, drives in and provides a cushioned expansion seal in one step with no pre-drilling and no panel cracking. Master One-Steppers are available in 304 and 410 stainless steel, or in carbon steel with Leland's renowned long-life platings and powder coatings. **Circle 115**



YOU'RE ON THE RIGHT TRACK WITH



## New Products

## ROUND TRACK AND BOX TRACK



Call us with your requirements today. We'll help you build the future.

(800) 553-5142

[www.westernproductsinc.com](http://www.westernproductsinc.com)

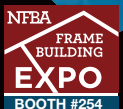

AN INDUSTRY LEADER IN QUALITY BUILDING PRODUCTS  
SLIDING DOOR TRACK AND HARDWARE · SLIDING DOOR  
FRAMES · WALK DOORS · WINDOWS · DUTCH DOORS · HORSE  
STALLS · CUPOLAS · POLYCARBONATE · PVC WALL LINER





**WICK BUILDINGS – EQUESTRIAN BUILDINGS**

From large arenas to small horse stables, Wick Buildings is a leader in equestrian facility planning and construction. Your Wick equine facility will accommodate and incorporate the latest technology for horse and human comfort and convenience. Planning on some second-story living quarters? Want to incorporate a viewing room into that arena? Would you like power-vented cupolas that bring in fresh air based on temperatures or humidity levels? Wick Buildings can do that and more. **Circle 116**



**TVM – RETRO-PAN INSULATION SYSTEM**

TVM Retro-Pan insulation system is an easy to install, cost-effective way to retrofit existing buildings to a better-than-new look and insulating value. By installing the system between the purlins, there is no costly removal of the roof or utilities. Made from a ¼-inch layer of 2.2 pound Polystyrene foam and a reflective surface, Retro Pan will solve your retrofit problems. **Circle 117**

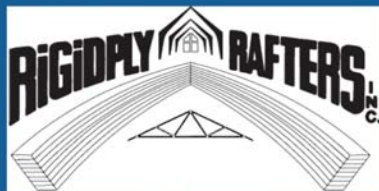

[www.rigidply.com](http://www.rigidply.com)

The Only Real Glu-Laminated Post -  
Choose Rigidply Rafters, Inc. for your  
next project!



701 E. Linden Street, Richland, PA 17087  
Phone: 717-866-6581 ~ Fax: 717-866-7237

[www.rigidply.com](http://www.rigidply.com)

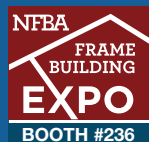

# Who's going to Louisville?

## Your guide to exhibitors scheduled to be at the trade show

BY THE TIME YOU RECEIVE THIS ISSUE, OUR STAFF WILL BE WELL INTO PREPARATIONS FOR THE FRAME BUILDING EXPO AT THE KENTUCKY INTERNATIONAL CONVENTION CENTER IN DOWNTOWN LOUISVILLE. We're looking forward to the trip, which always supplies us with great contacts and materials for future articles. Better yet, it allows us to talk personally with some of our readers and advertisers to find out first hand what's going on in the industry.

Our last issue included a brochure showing all the details of what to expect at the Expo: the workshops, the trade-show demonstrations, the hospitality events, the awards. In this issue we feature the businesses who will be displaying on the show floor. Take a look in the next several pages to see who will be there and what they will be showcasing.

If you haven't made your reservations yet, contact the National Frame Building Association at [www.nfba.org](http://www.nfba.org) or call 800-557-6957.

And if you can't make the show, circle the Reader Service Card number on the insert between pages 58 and 59 and send it in to receive more information.

Hope to see you at the show! **RB**

**NFBA**  
**FRAME BUILDING**  
**EXPO**

**2015**  
**FRAME BUILDING EXPO**  
**The Framework for Success**  
February 18-20, 2015  
Louisville, KY

### 3GM STEEL INC.

**Booth 633 / Circle 120**

3GM Steel Service Center provides quality pre-painted and bare products for your metal roofing requirements. Visit their booth for a detailed description of items including color, gauges and widths that are inventoried and ready for shipment at any given notice.

### A J MANUFACTURING INC.

**Booth 530 / Circle 121**

A.J. Manufacturing 4-way universal steel frame, composite frame and aluminum frame doors with steel, fiberglass or aluminum panels will be on display in Louisville. A.J.'s commitment to building ideas and providing its customers and the post-frame industry the highest value solutions are just part of what you'll see on display. Two Expo Live! Education Sessions make A.J.'s booth a must-visit during your time in Louisville.



### A.B. MARTIN ROOFING SUPPLY

**Booth 219 / Circle 122**

A.B. Martin Roofing is a manufacturer of quality metal roofing and siding panels including the ABM multi-purpose panel, the ABSeam standing seam panel and the PBR commercial panel. It provides building materials for pole buildings, including framing lumber, insulation, doors and windows, tongue-and-groove lumber and stalls for horse barns and much more.

### ADMIRALS BANK

**Booth 643 / Circle 123**

Admirals Bank is a federally-chartered financial institution

See you at the  
**2015 NFBA**  
Booth #219



# A. B. MARTIN

## ROOFING SUPPLY, LLC

Roofing & Siding • Hardware • Lumber

### ABM Metal Panel

#### 1. **Thicker Steel Coil**

Our premium panel is over 6% heavier than some competitors.

#### 2. **Heavier Zinc Coatings**

More Zinc or Aluminum means more rust protection.

#### 3. **Better paint bond**

Premium G-100 - Zinc Phosphate makes for a strong paint bond and better corrosion protection.

#### 4. **Manufacturer Paint Warranties**

Premium G-100 - Has 40 year Valspar paint warranty + 10 year edge rust warranty.

#### 5. **Heat Formed Panels**

We Pre-Heat the coil prior to rollforming. This will reduce the paint from cracking on the outside bends.

#### 6. **Larger Minor Ribs**

This strengthens the panel and improves the looks.

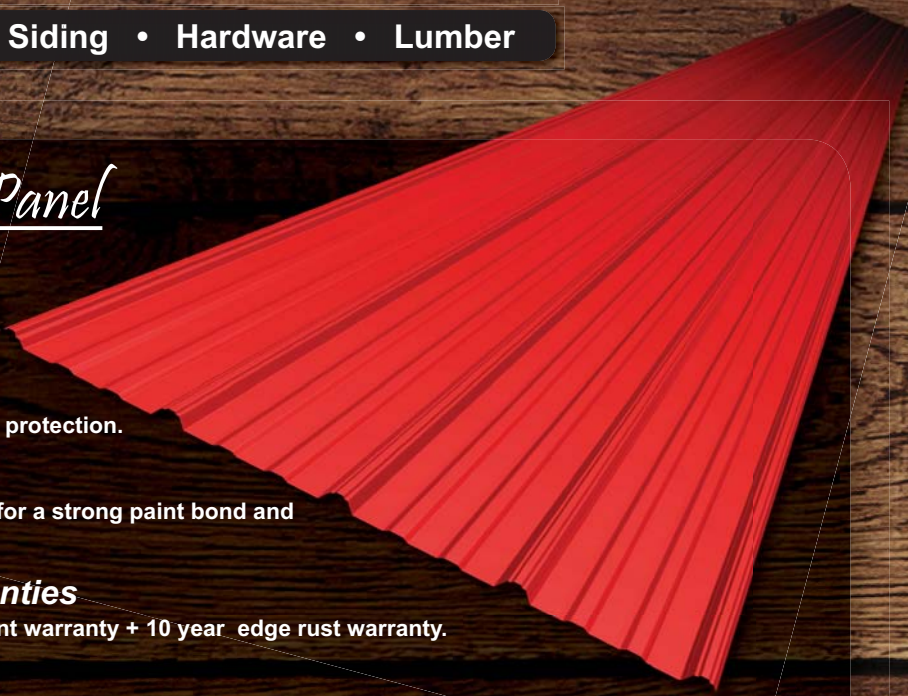

### Nationwide Wholesale

- Soffit
- Sealrite Screws
- Roll Door Track
- Double Bubble Insulation
- Ultra-Vent (ridge vent)
- Uplift Plates (post uplift)
- Glu-Lam Posts
- Cupolas
- Snowguards
- S-5! Snow Rails
- S-5! Solar Clamps
- Polycarbonate Skylights
- Agtuff (PVC wall & ceiling panels)
- Green Posts (Rot Resistant)



*Direct Shipped or Delivered from our Warehouse*

35 Ridge Road  
Newville, PA  
717-776-5951

[www.abmartin.net](http://www.abmartin.net)

Circle Reader Service #291

150 Slate Road  
Ephrata, PA  
717-445-6885

## expo exhibitors

BY RURAL BUILDER STAFF

headquartered in Boston, with a regional banking center in Providence, Rhode Island. As an FHA approved lender, Admirals Bank is the largest national provider of the Title I Home Improvement Loan. Admirals Bank has continued to focus its Title I lending efforts towards the residential and agricultural post-frame industry. The financing provided by Admirals Bank can be used toward the construction or repair of residential, hobby and agricultural post-frame structures in all 50 states. Admirals Bank is a Member FDIC, Equal Housing Lender and a proud Gold Club Member of the National Frame Building Association. All loans are subject to credit approval.



### AMERIPAK STRETCH WRAP SYSTEMS

**Booth 521 / Circle 124**

Ameripak Stretch Wrap Systems is a leading manufacturer of Ameripak Horizontal Stretch equipment designed specifically for unitizing and protecting metal wall and roof panels, standing seam panels, metal molding and trim. With the ability to talk or “handshake” with most roll forming equipment, Ameripak Horizontal Wrappers increase efficiency and output by speeding up the forming lines packaging process. Ameripak Horizontal wrappers are in use by many of the nation’s leading metal forming companies.

### AMERICAN BUILDING COMPONENTS

**Booth 425/ Circle 125**

Tirelessly committed to quality products and service, American Building Components has built a strong reputation of providing premium metal roofing and building solutions that customers



have relied on for more than a century. Servicing primarily the residential, commercial, post-frame and agricultural markets, ABC offers a wide variety of premium metal panels in both 29- and 26-gauge steel that are second to none. Utilizing only top grade painting technologies in its coating facilities, ABC steel is backed by industry-leading warranties that assure your projects will stand the tests of time.



### AKZONOBEL

**Booth 519/Circle 126**

AkzoNobel manufactures high performance coil coatings for the pre-painted metal construction industry, serving the commercial, agricultural, architectural and residential markets. Coil coating products include Trinar, a 70 percent PVDF coating, and Ceram-A-Star1050, which is the industry-leading silicone-modified polyester coil coating. Both are available in Cool Chemistry formulations which help make projects more energy efficient and sustainable.

### ANCO PRODUCTS INC.

**Booth 409/Circle 127**

Anco Products manufactures insulation solutions for post-frame and metal building applications. TextraFine post-frame insulation is fire and moisture resistant. Manufactured with recycled textile fibers, this insulation is earth friendly and resilient for excellent recovery. TextraFine also friction-fits, making installation quick and easy. This insulation is available up to 93 inches wide with custom lengths

available for laminated orders. Anco also offers 1- to 2-inch thick condensation control blanket ideal for noise abatement in horse arenas and animal barns.

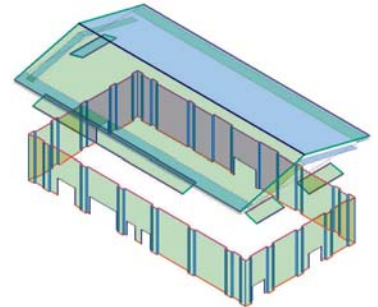

### APPLICAD-USA INC.

**Booth 128/Circle 128**

AppliCad is a specialized CAD application software development company based in Melbourne, Australia. AppliCad has developed CAD applications since 1989 and now exports its specialized software to roofing and cladding companies in 143 countries around the world. AppliCad also has offices in the U.S. and the U.K. Customers who benefit the most from using our software include metal roofing and cladding installers, contractors, distributors and manufacturers. They achieve this by improving accuracy, productivity and quality of output.

### ARCH WOOD PROTECTION

**Booth 419/Circle 129**

Arch Wood Protection recently introduced an additive for treated wood that provides enhanced defense against common fungi as well as against certain aggressive rogue fungi that can tolerate commonly-used residential preservative systems on the market. BARamine technology, for which a worldwide patent is pending, is being incorporated into the treatment of Wolmanized Outdoor Wood, the production of which is licensed by Arch Wood Protection.

### ASC MACHINE TOOLS INC.

**Booth 509/Circle 130**

ASC offers American-built quality roll forming equipment at a competitive price. ASC Machine Tools offers a line that is three machines in one. It cuts to length, slits with up to five knives and is a roll former. The roll former can be



**AkzoNobel**

**In all seasons  
and climates,  
CERAM-A-STAR®  
1050 sets the  
standard.**

Consistent, reliable  
and proven paint  
performance  
that stands the  
test of time.

CERAM-A-STAR 1050 coatings for prepainted metal have stood up to the harshest of elements throughout years of real-world exposure. Providing you with superior chalk and fade resistance and industry-leading gloss retention. CERAM-A-STAR 1050 is in it for the long haul.

Discover CERAM-A-STAR 1050's benefits at  
[www.akzonobel.com/ccna](http://www.akzonobel.com/ccna)

## expo exhibitors

BY RURAL BUILDER STAFF

single- or dual-height tooled with a g panel, R-panel, or up to three trim profiles on each level.

### ATLAS FASTENERS

Booth 630/Circle 131

The Atlas #10 WoodTite HLX Atlas High-Low Fastener is engineered with a Type-17 Point to penetrate the metal panel quickly. The Atlas HLX features specialized hybrid Aster threads that reduce pigtailed along with drive torque in hardwoods and knots. The high-major with low-minor threads ensures faster drill times.



inches wide, a full line of insulation accessories, reflective insulation, Thermax rigid insulation, Baylight prismatic skylights and Expi-Door walk doors with fire-rated and high-security features.

### BECK AUTOMATION LLC

Booth 343/Circle 133

Beck Automation is a leading control system provider for the metal forming industry. Beck designs controls and related products specifically for roll forming, cut-to-length, tube mills, portable roll formers and folding machines. Whether you are

looking for a control upgrade or office-to-shop software, Beck can provide the right solution to make your production lines more efficient and profitable. Stop by the booth to see how Beck can make your business run more efficiently.



### BECKER SPECIALTY CORPORATION

Booth 531/Circle 134

Becker Specialty supplies coatings for the industrial finishing of metal and plastic. It is a European market leader for coil coating paints and a key supplier of special coating systems for the industry.

# MASTER FLASH® 35 YEAR

**THE ONLY ICC FLASHING OF ITS KIND,  
Listed with the Florida & California Building Codes.**







Compliance with the following Codes:  
 International Building Code® (IBC) • International Residential Code® (IRC)  
 California Building Code® (CBC) • California Residential Code® (CRC)  
 Florida Building Code® (IBC) • Florida Residential Code® (IRC)



1-800-WASHER 5 (927-4375) • Fax: 858-513-4305  
[www.aztecwasher.com](http://www.aztecwasher.com) • [sales@aztecwasher.com](mailto:sales@aztecwasher.com)

Circle Reader Service #441

chiohd.com      residential | commercial | rolling steel





The Door to Quality.™

BOOTH#  
220



from C.H.I. OVERHEAD DOORS



Circle Reader Service #553

**BESTLINE BUILDING PRODUCTS**

**Booth 214/Circle 135**

The Illinois company specializes in soft-fits, rainware and accessories made to be perfect matches for roof and wall panels.

**BOTKIN LUMBER CO.**

**Booth 102/Circle 136**

The Botkin family settled in the Missouri Ozark Mountains in the 1800's where they started sawing hardwood logs to support their families. Moses Botkin started what would eventually become Botkin Lumber Company. Botkin has evolved into a full-service lumber company with plants located in Missouri, Illinois, Georgia and Oregon. It has matched high-grade raw materials with automated production processes to establish a nationwide reputation for customized high quality and low cost products to match its customers' diverse requirements.



**BRADBURY GROUP**

**Booth 431 /Circle 137**

The Bradbury Group of companies make an extensive line of roll forming equipment including panel and trim roll formers, folders, Panther Cub II Slitter/Shears, uncoilers and recoilers, stand-alone sheet slitters, hemmers, and gutter machines. Offered are equipment options for the startup producer as well as the established manufacturer. The companies of the Bradbury Group are known for

cutting-edge technology and reliability built into every product.

**BRUT POST GRABBER**

**Booth 600/Circle 138**

Never manhandle heavy posts again! The Brut Post Grabber skid steer attachment makes easy work of post placement. This innovative attachment was designed and developed by a post-frame building contractor. The Brut solves problems of safety, physical strain and hole sloughing. And, it's made in the USA.



**BURROW'S POST FRAME SUPPLY**

**Booth 518/Circle 139**

Burrow's Post-Frame Supply is an



Dual Level Rollformer with Underlayment Fixture

**Manufacturers of:**

- Panel and Roofing Rollformers
- Trim Rollformers
- Hydraulic Folders
- Coil Processing Lines
- Precision Levelers
- Insulated Panel Lines

See us at  
Frame Building Expo  
Booth #431  
Louisville, KY  
February 18-20, 2015



Ridge Cap Bender



Rat Guard Trim



Fascia Trim



Starter Trim



F and J Trim

[www.bradburygroup.com](http://www.bradburygroup.com)

THE BRADBURY GROUP

620.345.6394

Circle Reader Service #435

## expo exhibitors

BY RURAL BUILDER STAFF



integrated manufacturer and turnkey supplier of construction materials for the post-frame construction market. The company roll forms steel siding and steel roofing, custom manufactures wood trusses and laminated posts and manages a massive inventory of related lumber, steel trim and post-frame accessories. The relationships Burrow's builds with its distributor partners and builder-end customers are guided by the fact that it is stubborn about quality in everything it does for them.

### CANNONBALL:HNP Booth 143 /Circle 140

CannonBall – original inventors of round track and trolley – offers a wide range of door track and sliding door systems, entry doors, windows, horse barn systems, ventilation, polycarbonate building material and builders hardware for the agriculture and commercial metal building markets.



### CENTRAL STATES MFG. Booth 401/Circle 141

Central States manufactures metal building components for the post-frame, light-gauge, architectural, residential and commercial markets. Offerings include

both exposed and concealed fastener panel profiles, as well as trapezoidal standing seam panels in a selection of gauges, colors and warranties. Trim and purlins are also available. Complete mini, boat or RV storage packages are available through the Central Storage Works division.



### C.H.I. OVERHEAD DOORS Booth 220/Circle 142

If you are in the market for a residential, commercial, or rolling steel overhead door, look no further than C.H.I. Overhead Doors. The company, through its commitment to quality and value,

**TORSION SHAFT TECHNOLOGY ON UPPER AND FOLDING BEAM  
DEPENDABLE QUALITY FOLDERS FOR LIFE**  
SEE WHY SO MANY CUSTOMERS HAVE SWITCHED

**CIDAN MACHINERY**  
THALMANN FORSTNER  
ROLL PROCESSING

NFBA FRAME BUILDING EXPO BOOTH #613

611 HIGHWAY 74S, SUITE 700 PEACHTREE CITY, GA 30269 770.692.7230 WWW.CIDANMACHINERY.COM  
Circle Reader Service #531

**800-746-8273**

**DOORS**

- AG DOORS
- SHOP DOORS
- BARN DOORS
- AVIATION

NFBA FRAME BUILDING EXPO BOOTH #148

**HYDRAULIC**  
"One-Piece" DOOR  
OR  
**BIFOLD**  
STRAP LIFT and auto latch

The Door Leader **SCHWEISSDOORS.com**

Circle Reader Service #414

One-Piece  
...Lift Straps

recognizes the importance of delivering a reliable product. C.H.I. offers an impressive selection of models in a wide range of sizes so you can find a garage door to match your exact specifications.

**CIDAN MACHINERY INC.**

**Booth 613/Circle 143**

Cidan Machinery offers a complete line of metal forming devices. Whether you're looking for the sheer capacity of its top model, the MegaPro, the utility and flexibility of its Profi CTL system, or the efficiency and economy of its portable BA machine, Cidan has a model to fit your needs.

**CLARK INDUSTRIES INC.**

**Booth 647/Circle 144**

Clark Industries Inc., Monett, Missouri is a privately owned and operated company that has been supplying the building components industry with manufacturing equipment, parts and service for more than 35 years. Lines include roof truss gantry systems, multi-head truss presses, floor truss machines, column laminators, hips and jacks machines, post nailing machines and more.

**DIRECT METALS INC.**

**Booth 601/Circle 145**

Direct Metals Inc. is a master distributor of many products for the post-frame building market including fasteners, flashings, insulation, ridge vents, closures, sealants, anchors, doors and door hardware. Its American-made products such as Razorback Ridgeback and standing seam metal roof clips are now in stock at the Plymouth, Indiana, Midwest Service Center. Please visit booth #601 for a catalog.

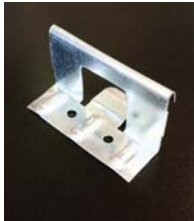

**DURA COAT**

**Booth 224/Circle 146**

Dura Coat specializes in high-quality, high-performance coil coatings for com-

mercial, farm and residential applications. Durapon 70 is a PVDF formulation equal to or better than any coating on the market. With an exceptional resistance to installation scratching, scuffing and transit abrasion, it is also flexible enough to handle demanding post-forming. The unique

chemistry of Durapon 70 reduces the carbon footprint which makes a greener product. Ceranamel XT-40 SMP is a proprietary polymer formulation that is harder and more flexible and significantly more abrasion- and stain-resistant than conventional coatings. Ceramic pigmentation prompted

## We Have Standard Fasteners, Tools, Sealants and Accessories

### ....AND MUCH MORE!





At Triangle Fastener, you will find the largest selection of specialty products in the industry. Our proprietary and patented products are designed for superior performance and fast installation.

- **VRT® Patented Back-Out Resistant Thread**
- **BRACER® Patented Hillside Washer**
- **BLAZER® Drill Screws**
- **CONCEALOR® Low Profile Screws**
- **ULTRA 1000® Silicon Sealant**
- **PIPEMASTER® Pipe Flashing**
- **Specialty Power Tools and Accessories**
- **Product Design and Engineering Support**



Scan our QR Code to find out more information about our products



**TRIANGLE FASTENER CORPORATION**

*Fastening Systems and Solutions for Construction*  
800.486.1832 | www.trianglefastener.com

Circle Reader Service #425

## expo exhibitors

BY RURAL BUILDER STAFF

the name, Ceramel. It runs like a dream at all speeds and has excellent flexibility, weathering and fade resistance properties. Both coatings are energy efficient and meet Energy Star standards.

### EAGLE METAL PRODUCTS

**Booth 144/Circle 147**

Serving the wood truss industry for more than 25 years with connector plates, truss design software, engineering services and manufacturing equipment, Eagle Metal is committed to providing exceptional products and customer service. Manufacturers across the country are discovering the advantages. Visit Eagle Metal Products' booth to learn more about its connector products and software solutions.

### EAST COAST FASTENERS & CLOSURES

**Booth 308/Circle 148**

Together with Plyco, East Coast Fasteners

produces top quality building supplies including toggle bolts, rivets, grommets, drill-bits, magnetic sockets, sealing washers, butyl tape, threaded fastener hardware, and HVAC duct strips. East Coast Fasteners & Closures provides the strongest and most effective building components for fastening wood, aluminum, steel, roof deck, plywood, drywall, insulation, gutters, concrete, brick, block and mortar.



### ENERGY PANEL STRUCTURES

**Booth 212 /Circle 149**

Energy Panel Structures specializes in pre-engineered buildings and tilt-up

panel systems for all types of construction. Since 1981 EPS has brought only the best building designs in commercial, agricultural, residential and cold storage.

### EVERLAST ROOFING INC.

**Booth 442 /Circle 150**

Everlast Roofing's metal and siding is uniquely superior to anything else on the market. Creating this success is the one-of-a-kind heat forming process, which prevents microscopic paint cracks. This enables the use of harder, more scratch-resistant paints. Offering a variety of gauges, colors and custom trims to suit every customer's application makes Everlast Roofing the perfect choice for the agricultural, commercial and residential markets.

### EXTRUTECH PLASTICS INC.

**Booth 209/Circle 151**

The Extrutech FORM System, for dairy



## SHEET METAL FOLDING MACHINE

Engineered for Speed & Accuracy!



**Single & Double Benders**

European-Designed & USA Made!



The Variobend technology guarantees outstanding clearance and unique profile variety!



Finally, an insulation for all below grade applications!



## Hitz Halter

- Proven by Unbiased, Real World Testing
- Owner, Shipper, and Installer Friendly
- 4' x 24' Fanfolded Sheets
- Termite & Insect Resistant • Will Never Waterlog



## RADIANT FLOOR HEAT Solution!

Call Today for More Information and Your Free Brochure on the Hitz Halter and Variobend!



Hershey's the Metal Meister, LLC  
Nelson Hershberger & Sons  
7405 E Mt. Pleasant Ln.  
Claremont, IL 62421  
**1-877-289-3030**  
PH: (618) 869-2222

Circle Reader Service #536

and car wash buildings, brings a bright new look to concrete form construction. The 24-inch wide by 6-inch thick panel is pre-cut to project specifications and snaps together with a double-spline, E-locking system. The company is certified ISO 9001-2008 QMS compliant and a U.S. Government certified supplier.



**FABRAL**

**Booth 539/Circle 152**

Fabral is 48 years strong and offers metal panel solutions, system components and accessories for agricultural, light commercial and residential projects. Fabral's solutions range from the good, to the best to the better! It gets you access to the right system your project demands. Backed by the best support in the industry, Fabral promises to work with you to get the job done right.



**FASCO AMERICA**

**Booth 151/Circle 153**

Fasco America offers a full range of Jumbo Nails and two well-designed tool models to conquer your BIG timber framing jobs. These tools have a side handle for extra support while driving the Jumbo Nails. Jumbo Nails are available in 4 inch to 6-3/8 inch lengths and can be ordered in many different finishes, shank deformations, points, and collations to meet your exact needs.

**FASTENERS DIRECT LLC**

**Booth 638/Circle 154**

Fasteners Direct manufactures the screws that attach metal roofing and siding. Fasteners Direct sells screws through distributors, along with accessories like closure, flashing and mastic tape, concentrating its efforts on supplying distributors with the best parts at the best prices and keeping them in stock.

**FILC USA/DRIPSTOP**

**Booth 507/Circle 155**

Dripstop from FILC USA helps fight condensation without insulation. Dripstop has specially-designed air pockets that store condensation and hold it until conditions change and it evaporates back into humidity. Because it arrives at the job site already on the steel, there are no costs for installing insulation, plus it



**BeckryTex**

NEW TEXTURED PAINT SYSTEM



**Beckers**

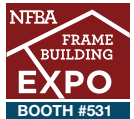

**Architectural low gloss anti-reflective coating**

BeckryTex technology allows you to design unique and distinctive exterior textured finishes. A flexible, low gloss polyurethane coating, it is most often used on roofing for a well defined wrinkled look that creates the appearance of materials other than metal. A wide range of popular colors are available in this weather resistant product.

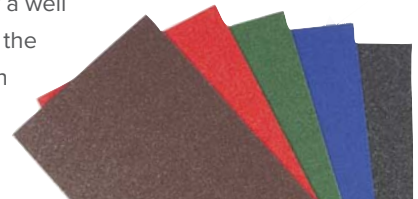

**Becker Specialty Corporation**

2526 Delta Lane, www.beckers-group.com  
 Elk Grove, IL 60007 rob.roy@beckers-group.com  
 P: (847)766-3555  
 TF: (800)782-2400

Beyond The Surface

Circle Reader Service #338

## expo exhibitors

BY RURAL BUILDER STAFF

saves time by removing one step of the building process and helps fight corrosion by adding another layer of protection from the corrosive elements found in livestock confinement.

### FLAGPOLES BY UNCOMMON USA

Booth 116/Circle 156

### GRABER POST BUILDINGS

Booth 437/Circle 157

Graber Post has everything for a post-frame structure or metal roofing project. GPB manufactures metal panels for any residential, commercial, industrial, agricultural or roofing application. Graber Post also produces custom trusses, metal trims, laminated poles and now also features a steel coils division. GPB saves you time and money by supplying all needed materials with just one phone call. Wholesale customers/distributors are desired.

### H & H METAL PRODUCTS

Booth 549/Circle 158

H&H manufactures and distributes quality steel roofing and siding products and accessories for the post-frame building and residential roofing markets, including CondenStop. CondenStop is a highly absorbent, layered fleece material containing millions of micro spheres that absorb and contain condensed water. It prevents dripping inside the building until the water evaporates.



### HERSHEY'S METAL MEISTER

Booth 543/Circle 159

Hershey's Metal Meister of Claremont Illinois, now manufactures Variobend folding machines, which were designed in Europe for speed and accuracy. Single and double folders have outstanding clearance and unique profile variety. Hershey's Metal Meister has experience in roll forming and designing equipment. It also offers radiant floor insulation, the Hitz Halter: finally, insulation for all below-grade applications.

### HIAB USA, INC.

Booth 313/Circle 160

### HOOVER TREATED WOOD PRODUCTS

Booth 344/Circle 161

Hoover Treated Wood Products Inc., in business since 1955, supplies a comprehensive portfolio of pressure-impregnated kiln-dried lumber and plywood products for fire retardant and preservative applications. Hoover has five company-owned treating facilities conveniently located to service a 100-plus member stocking distributor network, which thoroughly covers the USA and Canada. The rigorous quality control procedures employed by Hoover are constantly reviewed and inspected by Underwriters Laboratories and Timber Products Inspection's follow-up services.



### HÖRMANN LLC

Booth 134/Circle 162

As one of the world's leading manufacturers of doors, Hörmann is committed to providing a wide selection of German-engineered and American-made products. It includes the Orion 3200 (insulated sandwich) and Phoenix 500 (carriage house style) residential doors along with the Silent Driver 7500 garage door opener. Both doors come standard with FingerGuard pinch-resistant section joints for safety, plus 3-layer sandwich construction with polystyrene core and in-between section seals for increased energy efficiency.

### I-BEAM SLIDING DOORS

Booth 609/Circle 163

"Doors Done Right. Doors that Work!" is what I-Beam Sliding Doors stands for. Offered are doors from 6 feet x 6 feet up to 48 feet x 20 feet, sold standard with door frame, track systems, standard center latch



(military-grade bomb shelter quality) and handle and door hardware. I-Beam doors are constructed with a lightweight I-Beam aluminum door frame, and steel top and bottom rails and are engineered to withstand 90 mph winds.

### INDIANA WARM FLOORS

Booth 634/Circle 164

Since 1979 Indiana Warm Floors has been the authority in radiant floor heat, specializing in snow melt systems, radiant floor heat, geo-thermal heat pumps, IR tube heat, on-demand tank-less water heaters, and wood boilers. Radiant heat provides long-term energy efficiency with reduced operational and maintenance costs. Radiant heating is truly remarkable heat and is superior to traditional heating systems, requiring up to 30 percent less energy than a gas heating unit.

### INTEGRITY METALS

Booth 605/Circle 165

Integrity Metals offers metal roof and wall panels for light-gauge agricultural, light commercial and residential uses. Serving Kentucky, Tennessee, Indiana, Ohio, Illinois, Virginia and West Virginia, the Carolinas, Georgia and Alabama, the company is part of the "go green" market with Energy Star products, 40 year warranties and one of the best paint systems.

### JANUS INTERNATIONAL

Booth 131/Circle 166

Janus International is the leading manufacturer of roll-up doors for the commercial and self-storage markets. Headquartered in Temple, Georgia, Janus has five domestic locations and two international facilities. Ease of use, quick delivery, unparalleled warranty and strong customer





## Protecting the protectors

### APPLIED SCIENCE

*Dura Coat's team of resin experts made sure that that Station 37's roof is as durable as it is attractive. Ceranamel will help it withstand Colorado High Plains weather extremes.*

DURA COAT PRODUCTS, INC.

RIVERSIDE, CALIFORNIA  
(951) 341-6500

HUNTSVILLE, ALABAMA  
(256) 350-4300

[www.duracoatproducts.com](http://www.duracoatproducts.com)

WHEN THE NEW PLATTE VALLEY FIRE STATION WAS DESIGNED, it had to accommodate a range of professional emergency services such as fire, EMS, rescue and assists, as well as crew housing, community events, training and more. Quality was essential, but so was value.

For the metal roof, Dura Coat Products Ceranamel™ XT40S was specified, the finest coil coating available from resin specialists who are never sidetracked by making house paint or craft paint in spray cans. Ceranamel is tough enough to withstand Colorado winters and High-Plains heat. It applies fast and produces a ceramic/porcelain-type finish that is harder and more resistant to abrasions and stains than conventional coatings. And with an excellent hardness/flex ratio and internal lubricants, the coating handles the toughest roll-forming applications.

Ceranamel applies easily to primed hot-dipped galvanized, zinc-aluminum alloy steel, and aluminum substrates. Ceranamel is also Cool. Complying with Cool Roof Rating Council, Energy Star and LEED 29 standards, it helps the environment by reducing the carbon footprint. Protect your buildings 24/7 too.

Call 951-341-6500 for more information.

Circle Reader Service #581



## expo exhibitors

BY RURAL BUILDER STAFF

support has made Janus a favorite with door dealers nationwide since 2002.



### KENWOOD PAINTED METALS INC.

Booth 125/Circle 167

Kenwood is a single source supplier for preprinted metal for the construction and door industries with more than 30 years experience in the coil coating industry. It is a value-added supplier of pre-painted steel that will manage your supply chain, with stocking locations throughout the United States.

### KLOECKNER METAL BUILDING PRODUCTS

Booth 312/Circle 168

Kloeckner offers painted and bare coils for roll forming of building panels and components. Distribution is available throughout the U.S., offering more than 160 colors. Kloeckner provides paint systems in multiple grades, widths and substrates from Valspar, AkzoNobel and Dura Coat. Bare and acrylic-coated products, along with cold rolled, stainless and aluminum coil are stocked across the country. Kloeckner also distributes plate, beams, structurals, pipe and tubing. The company is headquartered in Roswell, Georgia, and consists of three business segments: Flat Rolled Group, Heavy Carbon Group and the Special Products Group which consists of building products.



### LANTOR BV

Booth 649/Circle 169

Lantor offers the leading condensation control solution in the construction industry with CondenStop. CondenStop effectively prevents problems caused by condensation in non-insulated metal buildings and roof systems. It can replace insulation blankets and vapor retarders to protect roof systems and building contents.

### LELAND INDUSTRIES

Booth 501/Circle 170

Leland boasts the fastener industry's first "long-life" powder coating warranty to match WeatherX, Spectracote and Perspectracote paint systems. Leland manufactures a complete line of fasteners for metal roofing, wood frame or steel frame projects, offering self-drilling and self-tapping fasteners in lengths to 4 inches in Nos. 10-12 and 14 diameters. Lengths up to 8 inches are also available.

# THE ONLY ONE-STEP FASTENER! for fiberglass or PVC panels!

**Master One-Steppers®** are the only time-saving one step screws for attaching panels that exhibit thermal expansion to wood frame structures. The revolutionary patented design self-drills an expansion hole, automatically centers, drives in and provides a cushioned expansion-seal in ONE STEP! No pre-drilling. No panel cracking!

**Master One-Steppers®** are available in 304 and 410 stainless steel, or in carbon steel with Leland's renowned long-life platings and powder coatings. Find out more today!

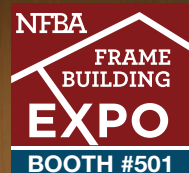

Hexavalent Chromium Free!  
It's the law.

Toll Free: 1-800-263-3303  
www.lelandindustries.com

Demand North American Quality!

Circle Reader Service #341

Leland fasteners are made of carbon or stainless steel, plated, coated or powder coated to match panel colors. Leland's powder coating covers both the head and under the head where corrosion starts.

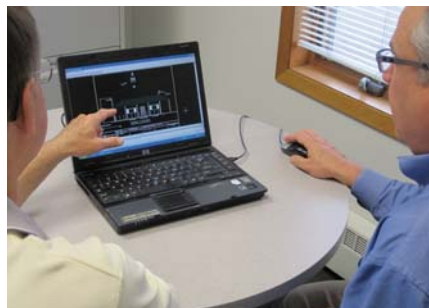

**LESTER BUILDING SYSTEMS LLC**

**Booth 137/Circle 171**

Lester is a leading post-frame manufacturer and builder with more than 150,000 buildings constructed since 1947. In support of its quality products and

engineering, Lester offers a structural warranty unmatched by others. Lester builders are equipped with time-saving sales tools like eBuildings instant online pricing and Improv software that can promptly design, price and engineer a building—right in front of the customer—when and where it's convenient. Lester is seeking professional builders who can leverage this innovative approach to selling buildings.

**LEVI'S BUILDING COMPONENTS**

**Booth 525/Circle 172**

Would you like to consolidate your roofing accessory orders? Visit Levi's Building Components' booth to discover a one-stop shop for your metal building fasteners and accessories. Levi's is a wholesale supplier of proven-quality products at fair prices with friendly service. Check out Levi's for fasteners, snow retention, venting, sealants and more.

**LIBERTY STEEL INC.**

**Booth 623/Circle 173**

Andrew Weller and his sons Andrew and James founded Liberty Steel Products in January of 1965. Today, the business operates four ISO 9001:2008 certified steel servicing and processing plants in Ohio and Mexico. Headquartered in North Jackson, Ohio, it processes all types of flat rolled carbon steel and provides a variety of state-of-the-art stamping and blanking services. Its innovative handling, staging and delivery systems are designed to enable its customers to meet the rigorous demands of the 21st Century "just-in-time" operation. Liberty Steel Inc. now offers a complete lineup of pre-painted products to the metal building industry. It has established relationships with metal coaters, paint companies and mills throughout the world, allowing it to offer the same "just-in-time" services to both new and existing customers requiring a pre-painted product at a competitive price.

**EDCO delivers beautiful exteriors with high-quality roofing and siding that is engineered to last a lifetime.**

*Talk to us any time with questions, we'd love to partner with you.*



**EDCOproducts.com • 800.593.2680**

## expo exhibitors

BY RURAL BUILDER STAFF



### MAC METAL SALES INC.

Booth 230 /Circle 174

MAC Metal is pleased to introduce a new panel offering to its customers. MAC Ultra is a true 28-gauge, .0153-inch minimum steel panel that is available in 11 colors to service the post-frame industry.

### MARCO INDUSTRIES

Booth 139/Circle 175

Economically and ecologically smart metal construction products from Marco

Industries include easy-to-use, reliable adhesives and sealants; rolled-edge super sealing doors; low- and ultra-low profile, extra griping clip screws; ventilation products with extreme durability, energy efficiency and outstanding warranties; pipe flashing; and a non-warping, non-corroding re-roof retrofit spacer. Together these products make up the Marco Weather-Tite System.



also offers a full service machine shop and re-tooling/service on other brands of equipment.

### MARTIN BUILDING PRODUCTS

Booth 421/Circle 177

Martin Building Products is a master distributor of reflective insulation, representing companies that supply the highest quality products in the industry. Martin sells to post-frame and red iron building distributors of all sizes who are promoting the growth of the metal building and the metal roofing

### MARION MANUFACTURING

Booth 124/Circle 176

Marion Manufacturing adds the value to the metal! It designs, fabricates and installs custom manufacturing and production machinery. Marion Manufacturing specializes in metal forming equipment such as: roll formers, uncoilers, shears, stackers, etc. It

## FIGHT CONDENSATION WITHOUT INSULATION

- Arrives on site already on roof panels
- Helps fight corrosion in livestock confinement
- Significantly reduces construction time
- Saves money



When condensation occurs, moisture gets stored in the specially designed pockets of the DR!PSTOP membrane.

It stops the dripping and eliminates the need for insulation and vapor barrier.

**ASK FOR IT  
FROM YOUR  
PREFERRED  
STEEL PANEL  
SUPPLIER**

### What Are Builders Saying About Dripstop?

*"All the owners, I have never had 1 complaint...we have done over 300 buildings and I have been back to 75 - 100 and they all love it" ... "I really do believe this is one of the best products to come out in our line of work"*

---Ohio builder

*"For us, we have had no complaints, no dripping, no issues, customers seem to really like it..."*

---Illinois Builder

*"With double bubble or insulation, you take twice as much time, you have to lay down the insulation, and then you have to lay down the steel"*

---Minnesota Builder

*"In windy days, you can still run roof"*

---Wisconsin Builder

Product Is Applied At Time Of Roll Forming

**DR!PSTOP**  
Condensation control 



VISIT US AT THE 2015 FRAME  
BUILDING EXPO IN LOUISVILLE!

[www.dripstop.net](http://www.dripstop.net)

Circle Reader Service #384

industries. Martin Building Products is independently owned.



**MAZE NAILS**

**Booth 100/Circle 178**

Maze Nails is the exclusive manufacturer of Stormguard double hot-dipped galvanized nails with a lifetime warranty against rust. In business since 1848, Maze offers a full line of specialty nails in bulk for hand driving and in collated sticks and coils for popular pneumatic nailers. Maze has been serving the post-frame industry for many years, providing painted rubber washer nails for corrugated roofing and siding. Maze post-frame nails meet ASTM F 1667 specification. In addition, Maze manufactures nails for fiber cement siding products, cedar and redwood sidings, fencing, decking and roofing. Customers have come to identify Maze Nails with top-quality products, excellent customer service and quick, dependable shipments. Help hammer out foreign competition one nail at a time and bring jobs back to America. All Maze Nails are proudly 100 percent made in the USA.



**MCELROY METAL INC.**

**Booth 309/Circle 179**

McElroy Metal's Max-Rib and MESA wall and roof panels feature Kynar 500 coating systems. Kynar 500 systems are proven to provide unsurpassed protection against fade and chalk. In addition, Kynar 500 coatings have superior gloss retention when compared to siliconized polyester coatings. The end result is a project that retains its aesthetics

and curb appeal year after year. With McElroy having 12 manufacturing facilities and 20 service centers you are sure to find a location nearby to serve you.

**MENARDS INC.**

**Booth 101/Circle 180**

Menards began as a seller and builder

of pole barns more than 50 years ago. Today it is the largest manufacturer and supplier of post-frame materials and services. The broadest selection of trusses, unparalleled steel panels and numerous trim shapes are in stock as well as custom trim made to your specs, laminated columns and much more. It has more

**UNITED STEEL SUPPLY**

When you need steel,  
**you can count on us.**

As the leading distributor of high quality flat rolled steel coils, you can count on United Steel Supply to offer competitive pricing, on-time delivery and superior customer service.

We furnish Galvalume®, galvanized, and prepainted coils for all metal roofing and siding applications. With a wide variety of stock colors and color-matching capabilities, you're sure to find what you need with United Steel Supply.

**NFBA  
FRAME BUILDING  
EXPO  
BOOTH #506**

For more information, visit [www.unitedsteelsupply.com](http://www.unitedsteelsupply.com) or call 512-263-0954.

**Circle Reader Service #564**

than 160 roll formers in service. The most complete design, engineering, technical drawings, presentation drawings and estimating services are available. Menards Stores offer a contractor program with a personal rep, contractor credit card and an expansive range of delivery options.



## METAL ROLLFORMING SYSTEMS

**Booth 637/Circle 181**

Metal Rollforming Systems designs and manufactures industry-leading roll forming equipment and accessories. MRS offers complete in-house design and a manufacturing facility allowing for competitive pricing, making MRS a leader in roll forming equipment manufacturing. MRS's product lines consist of single and double-deck roll formers, single and multi-trim roll formers, slitters and much more. MRS takes great pride in customer support both before and after the sale.

## METAL SALES MANUFACTURING CORP.

**Booth 118/Circle 182**

Metal Sales offers a complete line of metal roof, wall and fascia panel systems for the agricultural, suburban, residential and commercial markets. Celebrating 52 years of service in 2015, Metal Sales has the expertise to service post-frame builders and their customers' needs in new construction, expansion and retrofit. With the industry's largest and most knowledgeable sales and technical support team supported by 21 facilities nationwide, Metal Sales provides you with quality solutions for your building needs.

## METALFORMING INC.

**Booth 631/Circle 183**

Headquartered in Peachtree City, Georgia and privately held, MFI is the largest supplier of high-end architectural sheet metal machines in North America. It is

also a world leader in providing software, communications, training and consulting services for companies in the metal building and roofing industries, helping its customers to optimize both job site and factory operations in ways that reduce waste, increase revenue and efficiently position them to meet the "just-in-time" needs of today's construction business.



## MILL STEEL CO.

**Booth 319/Circle 184**

Now in its 55th year in business, Mill Steel is more dedicated than ever to its history of innovation and people-first culture that has made it one of the largest flat-rolled steel service centers in North America. Comprised of 12 production lines and four locations in Grand Rapids, Michigan; Detroit; Birmingham, Alabama; and a brand new facility in Jeffersonville, Indiana, Mill Steel guarantees quick turnarounds of pre-painted or bare steel for customized color match. Mill Steel proudly offers AkzoNobel and Valspar color systems.

## MSW CANADIAN PLASTICS

**Booth 126/Circle 185**

MSW Canadian Plastics Inc. is a leading profile extrusion company based in Palmerston, Ontario, Canada. It strives to produce high quality products that provide PVC liner panel and partition solutions to its customers. MSW believes that quality and customer service are the first priorities. Products the company manufactures include Trusscore, Ribcore and Norlock. It also offers custom extrusion. It has distribution partners across North America and also ships product to many countries around the world.

## MWI COMPONENTS

**Booth 225/Circle 186**

MWI Components offers more color

options for metal building components than anyone in the industry. With more than 100 colors available in steel, almost 30 different aluminum colors and 50-plus powder coat colors, the combinations are endless. This will allow builders and their customers to create beautiful and unique buildings using MWI cupolas, Ridg-Vents, soffit, trim, Arcadian sliding doors, Dutch doors, bale doors and stall systems.



## NATIONAL HARDWARE / SPECTRUM BRANDS

**Booth 138/Circle 187**

National Manufacturing Co. was started in 1901 as a small wagon company in Sterling, Illinois. The focus soon turned to manufacturing and selling general hardware. Over the course of the next century, National Hardware grew to be one of the leaders in builders' hardware. Today, the National Hardware brand has reached global status and offers more than 7,500 products. Its focus is on providing the best hardware and service to its valued customers.

## NEW PROCESS STEEL CORPORATION

**Booth 641/Circle 188**

This Indiana-based multi-divisional steel service center specializes in flat rolled carbon products, including all materials needed in the frame-building industry for panels and roofing. New Process has coil in galvanized, Galvalume and pre-painted materials. Several paint systems are available as well as custom painting through regional roll coaters.

## NOFP INC.

**Booth 112/Circle 189**

NOFP manufactures high performance

# NATIONAL FRAME BUILDING ASSOCIATION'S 2015 FRAME BUILDING EXPO

## Specialized Workshops for Building Professionals Across All Levels

FROM CREW MEMBERS TO BUSINESS OWNERS!

### OSHA 10-Hour Workshop on Construction and Safety



PRESENTED BY RAY WELLINGTON,  
ENERGY PANEL STRUCTURES, INC.

Whether you are an employer or an employee, if you are interested in recognizing, avoiding, and preventing safety hazards on a construction job site, you'll want to attend this two-part 10-hour workshop on safety.

**Part 1:** Wednesday, February 18, 1–6 pm

**Part 2:** Thursday, February 19, 7:30 am–12:30 pm

Attend both sessions and earn the 10-Hour OSHA card!

**NFBA members: \$50; nonmembers: \$75**

### Five Ways to Grow Your Business Profitably



PRESENTED BY K. P. PERSAUD

Learn practical, easily applicable strategies for growth and business development.

This workshop—crafted for senior managers—helps you determine and refine your unique selling proposition and target markets. Gain insight and diagnostic tools that will allow you to make your business a profitable, sustainable enterprise.

**Part 1:** Wednesday, February 18, 1–5 pm

**Part 2:** Thursday, February 19, 7:30–11:30 am

**NFBA members: \$300; nonmembers: \$400**

“K.P. has been coaching me directly and working with my business now for about 3 years. Our growth in financials, business acumen, and professionalism has been astounding.”

—Matt Greiner,  
president of  
Greiner Buildings

Circle Reader Service #378

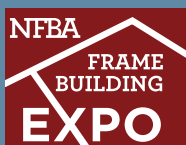

**2015 FRAME BUILDING EXPO**  
Kentucky International Convention Center  
Louisville, KY  
February 18–20, 2015

Learn more about  
these workshops and  
register at **NFBA.org**.

# IBeam SLIDING DOORS

**DOORS DONE RIGHT. DOORS THAT WORK!**

PHONE: 815-945-3667 • FAX: 815-945-7073 • WWW.IBEAMDOOR.COM  
900 E. CEMETERY AVE. CHENOA, IL. 61726



- Door kits are delivered to your desired location with all the hardware and frames pre-cut, pre-punched for ease of installation
- Doors are constructed of lightweight aluminum I-beams that are designed for openings up to 48' wide by 20' high
- Heavy duty military grade latches and high strength steel brackets and hardware are all included with door kits
- 10 year 90mph wind warranty; when you see it you will believe it; unlike any door out there
- Competitively priced to match your competitors wood or abusively heavy steel door systems

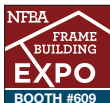

Circle Reader Service #512



**Safety, Durability and Beauty**



Our new and unique Orion 3110/3210 collection with TimberLast™ finish offer the durability of steel with the elegant look of natural wood. The new collection comes standard with Hörmann's exclusive FingerGuard™ pinch resistant section joints, a choice of either 1-3/8" or 2" steel sections and three layer sandwich construction with polystyrene core bonded to steel front and back.

To learn more, call us or visit our website or call us today.

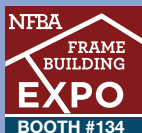

Hörmann LLC • 877.654.6762 • www.hormann.us

Circle Reader Service #538

## expo exhibitors

BY RURAL BUILDER STAFF

reflective foil insulation and under-concrete insulation for commercial, agricultural and residential construction. The new BarrierX5 under-concrete insulation is 1-1/4 inches thick and comes in a 4x60 foot roll of flexible EPS foam used for radiant heated floor and goes directly on the grade. It meets the R-5 insulation requirement for most radiant floor installations. It's a great replacement for rigid sheet insulation because it is flexible and won't break when walked on. In addition, it has poly film layers laminated to the top and bottom so it doubles as a vapor retarder.

### NORTH STAR METALS MFG. CO.

Booth 617/Circle 190

Established in 1994, North Star manufactures metal roofing, siding, custom components and assemblies for agricultural, architectural, industrial and residential markets. North Star utilizes state-of-the-art roll forming and folding equipment to produce consistently top-quality panels and trims exactly to order. A large selection of roll formed panel and trim is available and CNC folding capabilities allow North Star to satisfy any custom panel or trim requirements, including matching discontinued and hard-to-find panels. North Star also offers on-site delivery with crane-equipped tractor-trailer unit and roll-off capable gooseneck trailers.

### NOVAGARD SOLUTIONS

Booth 314/Circle 191

Novagard Solutions offers Novaflex Metal Roof Sealant for commercial and residential metal roofing applications. Novaflex Metal Roof Sealant offers superior performance and adhesion and easier use and cleanup than traditional solvent-based or polyurethane sealants. Novaflex is a specially-engineered high performance metal roof sealant that has been shown to offer more outstanding adhesion to Kynar-coated metal, steel and aluminum metal roof substrates than other roofing sealants on the market. It offers better UV resistance, better weatherability, tack-free time of less than 15 minutes, total cure in as little as 24 hours and has shrinkage on cure of 1- to 4-percent. It extrudes easily down to 0 degrees F and is mildew resistant.



### OFIC NORTH AMERICA INC.

Booth 342/Circle 192

OFIC North America manufactures Tuftex PVC AgLiner panels 38-inches wide for ceiling and sidewall applications in dairy, hogs and poultry confinement facilities or as an alternative to metal in high corrosive environments. Poly Lite polycarbonate 9- and 12-inch R-panel is available in clear smoke and translucent white.

### OHIO TIMBERLAND PRODUCTS

Booth 407/Circle 193

Ohio Timberland Products has long been considered the pioneering leader of nail-laminated column manufacturing and supply. It is flattered that while a number of "sup-

pliers” have emerged over the years copying its design, Ohio Timberland remains true to the engineering principals involved with column production. Ohio Timberland’s Christ-centered mission remains the same—to provide the post-frame community with the best quality nail-laminated columns delivered in a timely and economical fashion.

**PACESETTER STEEL SERVICE**

**Booth 618/Circle 194**

Pacesetter Steel Service Inc. is ISO-9001 Certified and a leader in the flat-rolled industry with products ranging from slit coil and blanks for segments of the industry, including but not limited to HVAC, grain bin, roll-up doors, metal buildings, as well as pre-painted and Galvalume coil for standing seam metal roofing and wall panels. For 38 years Pacesetter has been providing quality products backed by excellent customer service. With locations in Atlanta, Houston and Chicago, Pacesetter is positioned geographically to provide you the advantage of just-in-time shipping.

**PAINT VALLEY PARTS LTD. / ACU-FORM**

**Booth 620/Circle 195**

Acu-Form, a division of Paint Valley Parts, is a manufacturer of metal forming equipment such as the ag panel, stretch wrapper, corner, post cut shear, hemmer, slitter, J-channel, rat guard, uncoiler, table and roll, ridge cap and more for commercial and residential construction use. The company’s goal is to meet and exceed customer expectations. The No. 1 priority is to send customers a durable, top-performing machine that will give years of trouble-free service. Acu-Form uses D2 tool steel as a standard.

**PALRAM AMERICAS**

**Booth 533/Circle 196**

Palram continues to expand its SunSky polycarbonate panel line, allowing builders to offer more day lighting and side lighting options to customers. With Palram’s new MetalMatch Technology, it can match virtually any corrugated metal panel profile available with minimal order requirements. Palram also offers a complete line of Ag-Tuf PVC liner panels for interior and exterior use.



**PARAMOUNT METALS**

**Booth 114/Circle 197**

Paramount Metals provides 29- and 26-gauge Grade D and E coils to metal building manufacturers in the U.S. and Canada. Paramount’s goal is to provide service and guidance to help businesses grow. Paramount stocks a full line of coil inventory including 20-inch standing seam coils. Paramount is better able to control delivery by using its own trucks and has the ability to provide several common trims and trim flat sheets.



**PERMA-COLUMN INC.**

**Booth 412/Circle 198**

Perma-Columns are 5-foot precast concrete columns that keep wood out of the ground, ensuring your building’s foundation will never rot. They are the first product to combine the economy of post-frame construction with the durability of a concrete foundation.



**PLANET SAVER INDUSTRIES LLC**

**Booth 614/Circle 199**

GreenPost offers a unique non-toxic concept for protecting in-ground wood from the harmful effects of ground contact decay, at the same time providing uplift restraint. GreenPost is laboratory proven, termite tested and building-code compliant and is applied to posts using a specialized production machine so posts arrive ready for installation. GreenPost also complements pressure-treated posts by providing an environmentally friendly barrier, helping to keep the preservatives in the post longer.



**PLASTI-SLEEVE / HOMEWORK DESIGN**

**Booth 119/Circle 200**

With 19 years in production, the original Plasti-Sleeve is



**Paint Valley Parts, Ltd.**

**10550 Township Road 262**  
**Millersburg, OH 44654**  
**Phone 330-674-4003**  
**Fax 330-674-4035**  
**pvp@paintvalleyequipment.com**



**PAINT VALLEY PARTS / ACU-FORM**

Acu-Form (a division of Paint Valley Parts) is a manufacturer of metal forming equipment, such as the Ag Panel, Post Cut Shear, Uncoiler, Corner, J Channel, Ridge Cap, Rat Guard, Hemmer, Slitter, Wrapper, Tables & Rolls, Etc. Also Machines made to your specs. Our goal is to meet and exceed our customer’s expectations. Our number one priority is to send our customer a durable top performing machine, that will give you years of trouble free service. We use D2 tool steel as a standard.





**Circle Reader Service #516**

# WE DON'T WANT TO TELL YOU ABOUT CONDENSATION PROBLEMS

## WE JUST OFFER THE SOLUTION

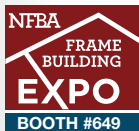

### CONDENSTOP®

Reliable condensation control in metal roofs & buildings

Mike Shelburne  
CONDENSTOP Sales Manager  
Work address: P.O. Box 178,  
New Washington, IN 47162 USA  
Telephone: Mobile (502) 548-4631 • Email: mike.shelburne@ngnx.com (Work)



Circle Reader Service #521



### The Affordable Rollforming Equipment Manufacturer

Metal Rollforming Systems designs and manufactures reliable and affordable rollforming equipment and accessories, making us a leader in rollforming equipment manufacturing. Our unsurpassed technical support is unlike any other in the industry, we work until the job is done. Our customer's success is our success. For more information, please contact us at 1.888.284.6794 or visit us online.

- Single & Double Deck Rollformers
- Trim Rollformers
- \*NEW\* Patriot Rollforming Line
- Coil Reels

- Precision Cut Slitting Lines
- Sheet Stackers
- Coil Upenders
- Ridge-Cap Press



1.888.284.6794 [www.mrsrollform.com](http://www.mrsrollform.com)

**MADE  
IN USA**

Circle Reader Service #584

## expo exhibitors

BY RURAL BUILDER STAFF

a leader in post protection for buildings, offering economical, versatile and easy slide-on installation for 18 different post sizes.

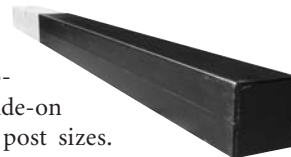

Made in the USA from the highest quality black HDPE plastic, Plasti-Sleeve offers unparalleled in-ground durability. Newly patented Plasti-Skirt, an economical protective plastic skirt board cover, is available for 2x8 and 2x6 skirt boards.

### PLYCO CORPORATION

Booth 201/Circle 201

Plyco manufactures a full line of walk doors and windows to meet today's building codes. From agricultural and outbuildings to commercial fire- and wind-rated to residential, Plyco can supply quality products to fit your needs. Plyco track, SDR, ridge vents, cupolas, slide doors, Dutch doors, Champion doors, Equus products and Ply-Foil help make your life easier with one-stop shopping. East Coast Fasteners can fill your fastener requirements for a complete package.

### POST PROTECTOR INC.

Booth 327/Circle 202

Post Protector is a slide-on barrier system, delivering serious post decay protection. Post Protector tackles post longevity concerns by eliminating both soil/concrete-to-post contact and chemical migration. Post Protector retains the simplicity, affordability, speed and strength of typical post-in-ground construction technique. Horizontal perimeter ribs, in conjunction with provided hardware yield substantial post uplift protection and best of all, installation is a snap. It's simple: by keeping soil out and treatment in, Post Protector dramatically improves post-frame foundations!

### POWER LIFT HYDRAULIC DOORS

Booth 243/Circle 203

PowerLift Hydraulic Doors is North America's largest hydraulic door manufacturer. With more than 23 years experience, PowerLift custom designs and installs



doors for agricultural, aviation, commercial and residential projects. Each local PowerLift manufacturing location offers the industry's only lifetime structural warranty. For doors built to last a lifetime contact PowerLift.

### PPG INDUSTRIES

Booth 602/Circle 204

PPG metal coatings balance the performance and budget demands of building product manufacturers, building owners and architects. DuraStar SMP (silicone-modified-polyester) and DuraForm next-generation polyester coatings deliver long-lasting, value-oriented color and protection for metal panels,



roofs, door frames, garage doors and more. DurAnar fluoropolymer coatings, including IR-reflective DurAnar Ultra-Cool and Vari-Cool coatings, provide exceptional performance for high-end wall panels and roofing applications, even in harsh seacoast, desert or industrial environments.

**PRECOAT METALS**

**Booth 516/Circle 205**

You name it, Precoat Metals can process it. With 13 plants strategically placed, the ability to coat up to 72 inches wide and an extensive line of processing capabili-

ties, Precoat Metals has positioned itself as an industry leader. From its outstanding customer service, to its attention to detail they've got you covered. Precoat Metals: your one-stop shop for your coil coating needs. Visit the Expo booth to view the company's innovative products.

**PROGRESSIVE METALS INC.**

**Booth 345/Circle 206**

Progressive Metals aims to meet and exceed all customer coil needs. Offering high-quality metal in many colors, excellent service and exceptional delivery will put Progressive Metals on the top of your list as the choice for all your metal roofing options.

**PROPEL SLIDING DOOR AUTOMATION**

**Booth 611/Circle 207**

Propel makes life easier. You have a remote for your garage door, why not your sliding doors? Propel's award-winning, patented system automates slid-

ing shed doors at a fraction of the cost of overhead door systems. The system was designed specifically for single- and split-sliding shed doors. It's the most effective, least expensive way to automate your doors. Perfect for retrofit and new construction. Propel's system features no loss in opening height and minimal loss in opening width. Works on doors up to 42 feet, and it's easy to install.

**RADIANT OUTFITTERS**

**Booth 621/Circle 208**

Radiant Outfitters specializes in hydronic radiant floor heat. Radiant floor is a popular option for post-frame builders. Radiant Outfitters takes the guesswork out of floor heat for building contractors. Radiant Outfitters offers very unique tubing that has 20



**BORN IN FIRE**  
 NOW IN 36  
**POWDERFUL™**  
**COOL**  
 METAL COLORS

**40 YEAR WARRANTY SEALTITE STRONG**

COME SEE US AT BOOTH 413 NFBA EXPO

**ZXL WoodBinder®**

The journey for all carbon steel fasteners begins in a heat treat furnace. However, it is the engineering excellence & functional, yet attractive design that separates the **ZXL WoodBinder®** from competitive long-life screws.

- Head is molded for maximum pullover strength.
- KWIKSEAL® thread & point designed for today's high quality residential & commercial metal roof panels.
- Available with POWDERFUL™ powder coat paint system.
- EPDM rubber washer fits securely underneath the head.
- Written 40 year warranty against red rust on the head is available upon request.

**No Red Rust**



Molded ZAMAC 5 Zinc-Aluminum alloy provides maximum protection against red rust

CALL TODAY 800.352.4864



Circle Reader Service #429

**Novaflex. The flexible seal that lasts as long as the roof.**



Your reputation depends in large part on the materials you use. Build a reputation for dependable performance with Novaflex® Metal Roof Sealant. Novaflex gives you superior flexibility and adhesion to most construction materials, including metal, coated metal, wood, masonry, PVC, and Kynar®. It's easy to apply, especially in cold weather, and easy to clean.

**NOVA FLEX** SILICONE

*When you want the seal to last®*

[www.novagard.com](http://www.novagard.com)

**Visit us at Frame Building Expo Booth 314**

Circle Reader Service #290



**TVM RETRO-PAN -** For Metal Buildings & Pole Barns

**RETRO-PAN YOUR BUILDING**



**Before & After**

**ADDS R-9**

- Class 1/ Class A Fire Rating
- Most cost effective way to Retro-fit
- Installation is quick, safe and easy

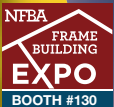

**CONTACT US AT**

**814.269.9674**

**[www.tvmi.com](http://www.tvmi.com)**

Circle Reader Service #600

**expo exhibitors**

BY RURAL BUILDER STAFF

percent better heat transfer and the highest pressure and temperature ratings on the market. Add floor heat to your offering and add to your profits.



**REPLICATIONS UNLIMITED**

**Booth 149/Circle 209**

The Urestone Professional Series from Replications Unlimited represents the latest technology in interlocking faux stone and brick panels. Replications Unlimited has developed a unique line of high quality large 4-foot x 8-foot panels and an accompanying wainscot series that measures 42 inches high x 8 feet that includes a built-in 4-inch top trim. Both series are extremely realistic in appearance, durable, lightweight, provide energy savings and are easier to install than other stone and panel systems.

**RICHLAND LAMINATED COLUMNS**

**Booth 218/Circle 210**

Laminated columns are an industry standard and Richland Laminated Columns continues to offer post-frame builders an increasing range of products. In 2010, it acquired the rights to manufacture and distribute Perma-Column. Combined with Sturdi-Wall brackets, Footing Pad by Ag-Co and the Post Protector, the customer now has access to a full range of post protection products.



**RIGIDPLY RAFTERS**

**Booth 236/Circle 211**

Rigidply Rafters has improved the quality of post-frame buildings by manufacturing and distributing the original 100 percent glue-laminated post. By specifying Rigidply Posts, you guarantee the labor saving and quality advantages of true glulam posts. Not only are glulam posts lighter, straighter and stronger than solid sawn posts, but

they minimize cracking and splitting. When planning your next building project, count on Rigidply Rafters to supply integrity, quality and service with your glulam posts.

**S-5!**

**Booth 226/Circle 212**

S-5! products attach ancillaries securely to almost any metal roof profile, including exposed-fastened and corrugated. Brackets boast unprecedented holding strength, making them ideal for heavy-duty applications such as the S-5! ColorGard snow retention system. The latest innovation in an expanding line of brackets is the versatile ProteaBracket, designed to fit any trapezoidal sheet shape. ProteaBracket is ideal for medium-duty applications and is compatible with the S-5 PV Kit for mounting and bonding solar panels.



**SAFE-WAY GARAGE DOOR**

**Booth 215/Circle 213**

Safe-Way Door manufactures a complete line of residential and commercial sectional garage doors in steel, wood and aluminum. They are available in multiple configurations including insulated, un-insulated and up to eight colors depending on the model. Panel configurations include three raised panel designs, ribbed steel and stamped carriage offerings. Commercial door sizes are available in all of the panel designs. Also offered is an aluminum service station door with full-vision sections. All Safe-Way doors come with heavy-duty track, hardware and 11 ball nylon rollers. Safe-Way also sells Lift-Master openers and carries stop-molding products and other accessories.



**SCHWEISS DOORS**

**Booth 148/Circle 214**

Schweiss Doors has been a leading manufacturer of hydraulic one-piece doors and patented Lift Strap/Autolatch Bifold Doors for more than 35 years. Renowned for its quality craftsmanship, Schweiss' custom-made engineered doors are specially designed for many applications, including commercial, industrial, agricultural, residential, hangars and designer doors. A Schweiss rep will demonstrate working models of both style doors at the Frame Building Expo.

**SEALTITE BUILDING FASTENERS**

**Booth 413/Circle 215**

Sealtite supplies steel-frame and post-frame screws for agricultural, commercial, industrial and residential metal roof applications. Product strengths are drill quality and corrosion resistance, showcased on the Maxx Steelbinder drill screw and Kwikseal II post-frame screw. Both products are greatly enhanced by Sealtite's powder coat paint process, which improves corrosion resistance 300 percent versus wet-paint processes. Sealtite markets its Woodbinder HSS full hard 304 stainless steel screw, which requires no pre-drilling in metal panels, and the ZXL Woodbinder zinc-aluminum alloy head for roof systems requiring a 20-year or longer warranty. Solid and vented foam closure strips, pipe flashings, pancake- and wafer-head screws for standing seam roofs and other accessories round out the product line.



**SEMMLER SYSTEMS INC.**

**Booth 426/Circle 216**

Big Red 111, Semmler's newest model for fabricating wood laminating columns features a new design that contains 10,000 nails in one loading. Special design of in-line equipment best saves plant layout space and requires only one operator for the total system. Total system equipment includes the Big Red fabri-

**TRI-STATE LUMBER CO.**

Fulton, Mississippi www.homanindustries.net (662) 862-2125

NFBA FRAME BUILDING EXPO BOOTH #417

**POST FRAME CONSTRUCTION**  
4x4, 4x6, 6x6, 6x8, 8x8, 10x10, 12x12  
*We Specialize in Long Timbers Treated CCA*

**CUSTOM SAWN LUMBER**  
3x8, 3x10, 3x12, 4x8, 4x10, 4x12  
*Most dimensions up to 40 feet long*

**FENCING & POST**  
1x6, 2x6, Round & Square Post Treated  
*Full Inch Corral Boards Cut 12, 14, 16 feet*

**REMANUFACTURING**  
Precision End Trimming, Dadoing, Drilling  
*No job too big or too small*

**T&G CENTER MATCH**  
2x6, 3x6, 4x6, 2x8, 3x8, 4x8  
**V-JOINT**  
2x6, 3x6, 2x8, 3x8

Quality

Quick Shipping

Fair Pricing

Circle Reader Service #576

## expo exhibitors

BY RURAL BUILDER STAFF

cator, conveyor system, gusset press, planer with chip collector, bunk-stacking cart with flanged wheels and track. Now available is the finger joint system that features unique finger joint detail. Available with jib crane with vacuum lift and scissor lift.

### SEWARD ASSOCIATES LLC

Booth 121/Circle 217



### SFS INTEC

Booth 325/Circle 218

SFS intec is a premier manufacturer of fasteners for metal panel attachment for metal building and post-frame markets. The #12 Woodgrip XG, with a large aggressive thread design, provides superior performance in OSB and plywood. Other fasteners include #9 Woodgrips, #10 HiLo MP, EverGrip bi-metal screws, and WoodZAC and WoodMAC SS capped fasteners. Accessories include ProfileVent ridge ventilation, pipe flashing and WG-7 foam closure.

### SIMPSON STRONG-TIE CO. INC.

Booth 113/Circle 219

Simpson Strong-Tie works closely with industry professionals to provide code-

listed, field-tested products, and value-engineered solutions. Its product lines include structural connectors, fasteners, wood and steel strong-wall prefabricated shearwalls, anchor tiedown systems for multi-story buildings, Quik Drive auto-feed screw driving systems, and Anchor Systems for concrete and masonry. Simpson Strong-Tie products are known for their consistent quality and availability as well as for helping structures resist high winds, hurricanes and seismic forces.

### STEEL DYNAMICS INC.

Booth 443/Circle 220

Steel Dynamics is a leader in the production of high-quality, low-cost, pre-painted steel for the metal construction industry. Its wide-width, light-gauge, pre-painted flat-rolled steel is perfectly suited for roof, wall and fascia systems used in the construction of metal structures. Also, SDI's pre-paint lines run parallel to its galvanized and Galvalume lines, reducing transportation costs and shortening the supply cycle, and that saves time and money.

### STILETTO TOOLS

Booth 238/Circle 221

Stiletto's Titanium Ti-Bone hammer has become the tool of choice for professional post-beam and pole-barn framers in the U.S. and Canada because the 20-, 30- and 60-penny spikes these builders use are hammer and elbow killers. Titanium offers 10 times more dampening of recoil shock than steel hammers



and has an indefinite service life with its replaceable steel faces.



### SWENSON SHEAR

Booth 109/Circle 222

Swenson Shear has been in business since 1959, supplying the metal construction industry with innovative and unique metal cutting tools. From its Model 20 for soffit and metal shingles, to the Model 64 for hip and valley cuts, the original Swenson Shear is a must-have for all of your exposed fastener profiles. Swenson also offers its SnapTable HD, a one-of-a-kind notching, slitting and hemming tool for your standing



2015 NFBA Frame Builders Expo—Louisville, KY  
February 18-20 Kentucky International Exposition  
Center

### Increase Your Sales.....

Our method will eliminate rework due to handling damage.

Ameripak wrappers will allow you to contain and protect your finish product metal. Wrapping metal saves time and makes sense.

1-800-942-9194

sales@Ameripak.net



www.ameripak.net



Circle Reader Service #569

seam job site. In addition, Swenson offers the One-Arm Bandit Stone Cutter. This rugged shear will stand up to the brutal wear and tear of the stone-coated steel job site.



**SYMUN SYSTEMS/  
CONSTRUCTION MAESTRO**

**Booth 104/Circle 223**

Construction Maestro, known for its detail, accuracy and ease of use, automates the process of generating all necessary field-ready plans and materials lists within just a few minutes for a post-frame or stud-frame building.

**TAYLOR STEEL INC.**

**Booth 217/Circle 224**

For more than 46 years, Taylor Steel Inc. has been supplying the building products and construction markets throughout North America. With an extensive inventory of bare and pre-painted coil and sheet, Taylor Steel offers a quick turnaround for your standard or custom supply needs.

**TIMBER TECH ENGINEERING INC.**

**Booth 106/Circle 225**

Timber Tech Engineering provides structural design of building components and complete building systems for post-frame and light wood constructed buildings. Timber Tech also offers structural design of foundation systems, roof systems, concrete, masonry and steel. Engineer's certifications are available for all 50 states and Canada. Designs are customized for each specific application. Timber Tech would enjoy the opportunity to review its services with you as well as show you some of its recently completed projects.

**TRIANGLE FASTENER CORP.**

**Booth 213 /Circle 226**

Triangle Fastener is a leading supplier of standard and specialty fasteners, tools, sealants and accessories for the commercial construction industry. A complete line of fasteners for metal-to-

metal, metal-to-wood, drywall and concrete anchoring is available from each of its 24 locations. Triangle's "Need-It-Now! Program" is designed to provide fastening solutions for difficult applications. Triangle has eight in-house painting facilities that can custom color match fasteners to exact requirements with deliv-

ery in three days or less. Triangle offers job site assistance, technical assistance, Pak-One inventory management programs and product devel-



# PEEL IT. SEAL IT. DONE!





**Peel & Seal®** is the original self-adhering waterproofing membrane designed for low slope roofing or flashing applications. This single-ply membrane applies directly to the roof deck and serves as the final roofing surface. Ideal for hundreds of applications including whole roofs, dormers, sunrooms, metal roofs, and flashing around exterior penetrations.



- Ideal for difficult roofing applications
- Aggressively adheres to the roof deck
- Self-seals around fasteners
- Aluminized surface limits solar gain
- Easy handling and installation
- Requires no coatings or coverings for permanent exposure to sunlight
- Virtually maintenance-free
- Variety of widths and color options
- 10-year limited warranty
- Made in the USA



800-882-7663 | [www.mfmbp.com](http://www.mfmbp.com)

Circle Reader Service #412

## expo exhibitors

BY RURAL BUILDER STAFF

opment. The TFC Fastening Systems Guide can be found on the website, and is complete with products and technical information on a wide variety of fastening systems solutions.

### TRI-STATE LUMBER COMPANY

Booth 417/Circle 227

Tri-State manufactures southern yellow timbers at its Fulton, Mississippi sawmill (from 4x4s to 10x10s). It has dry kilns and planer as well as re-saw and re-man capabilities. Tri-State Lumber can also center-match 2-x's and has a treating plant that treats CCA as well as dispersed copper azole. It can also do larger timbers and specialty timbers on a by-order basis.

### TRITON BARN SYSTEMS

Booth 108/Circle 228

### TVM INDUSTRIES

Booth 130/Circle 229

TVM supplies reflective bubble insulation in many sizes and configurations to complete any job. It also provides scrim-tough radiant barrier when the job calls for it. You can count on TVM for sealants, foam and tape products that will put the best finishing touches on all of your insulation projects. TVM was awarded with one of the best three new eGuide products in 2014 by *Rural Builder* for its retro pan replacement ceiling product. Please stop by booth 130 to see all of these exciting products from the people that know insulation.

### UNION CORRUGATING

Booth 606/Circle 230

For more than half-a-century, Union Corrugating has served the metal building components industry, including residential, commercial and agricultural roofing and siding markets from 10 manufacturing facilities.

### UNITED STEEL SUPPLY

Booth 506/Circle 231

United Steel Supply is a leading distributor of Galvalume, galvanized and pre-painted steel coils for metal roof and siding applications in the agricultural, commercial, industrial and residential markets. The company's products are made of the highest quality steel, allowing customers to maximize production efficiency and provide top quality material and efficient yield to final users. Stop by the booth to get a quote, make a purchase or hear about what United can do for you.



Universal Forest Products



United Steel Supply

## BIG RED III

### Make Your Own Nail-Lam Column

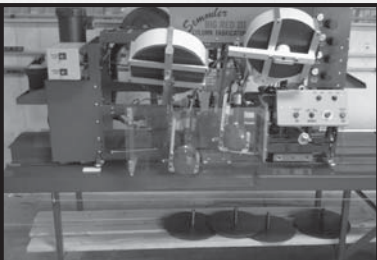

## ONE STOP SHOP

Total Fabricating System

- Fabricates up to 140 3-ply 16'0" columns without reloading
- Total inline fabricating equipment, planner, conveyor, stacking cart
- Finger joint equipment options
- Requires only one fabricator
- Column engineering and design
- Fabricates 3 ply, 4 ply, 2x6 and 2x8 columns

NFBA  
FRAME  
BUILDING  
EXPO  
BOOTH #426

SEMMLER  
SYSTEMS  
INC

Column  
Fab. Equip.  
Leader

Ph: 605-787-4765

Email: jimsemmler1@msn.com

www.semmlerinc.com

Circle Reader Service #454



## LAM-PLY TRUSS

The Truss That Will Carry The Load

- Spans up to 72 ft.
- Spacings up to 12 ft. on center, depending on the load you desire
- Bird Nesting Control
- Better Ventilation & Visibility
- No Feed Alley Post Obstruction
- Additional Ceiling Height

### Starwood Rafter Uses

- Pole Sheds
- Free Stalls
- Pavilion Shelters
- Machinery Storage
- Riding Arenas
- Solar Barns



Starwood Rafters, Inc.  
W24141 Starwood Lane  
Independence, WI 54747  
(715) 985-3117 • 888-525-5878

www.starwoodrafters.com

Circle Reader Service #375



**UNIVERSAL FOREST PRODUCTS**

**Booth 513/Circle 232**

Universal Forest Products is an industry leader in custom-engineered trusses, treated lumber and column materials designed and manufactured to exact specifications. UFP guarantees standout service and reliability on each and every project it takes on. Its reputation for delivering the highest quality, custom framing components to post-frame construction builders has been diligently earned, and customers trust UFP to produce and deliver the right products the first time, on time, every time.

**VALLEY LUMBER**

**Booth 133/Circle 233**

Valley Lumber supplies treated timber, lumber, plywood and post and manufactures Ultralam columns, 100 percent glulam, all from Number 1 Southern Yellow Pine.

**VALSPAR CORPORATION**

**Booth 424/Circle 234**

For more than 200 years, Valspar has been a leader in the art and science of coatings that excel in both beauty and function. The expansive range of superior coatings comes to life through a full palette of colors and surface textures to meet the most demanding environmental conditions and designs. WeatherXL—more of what made WeatherX your first choice—is the latest in cutting-edge formulation. It is recognized for its durability and offers even stronger protection against weathering and superior scratch resistance. Ideal for commercial and residential metal roofing, agricultural and industrial buildings and metal wall panels, WeatherXL lives up to its reputation.

**WAYNE DALTON**

**Booth 146/Circle 235**

As a leading brand in the garage door industry since 1954, Wayne Dalton is



American Made product offerings include Panel Clips , Butyl Tape, Self Drill Fasteners, Ventilation, Sealants, Translucent Panels, Doors, Track and Frame, Windows, Closures, Tapcon, REDHEAD Anchors and more.

Serving Distributors all across the U.S.A.

Ph 855-800-8878 [www.directmetalsinc.com](http://www.directmetalsinc.com)



Please visit us at the NFBA Show  
Booth 601, February 18th-20th  
in Louisville, KY.

## expo exhibitors

BY RURAL BUILDER STAFF

committed to offering a wide variety of distinctive designs to complement any elevation. With over 16 residential door collections and a multitude of color, glass and decorative hardware options, Wayne Dalton is able to suit the personal taste and architectural style of virtually every

customer. Pictured above is the Wayne Dalton Model 9700 Carriage House Steel.

### WESTERN PRODUCTS OF INDIANA Booth 254/Circle 236

Whether you use box track or round track, you'll find the strength, shape,

size and operational smoothness you desire in door tracks, hangers, trolleys, brackets, sliding door accessories, bottom guide systems and frames from Western. Choose from box track options of 400- to 1,000-pound capacity or round track at 600-pound capacity. Discover the convenience of Western's complete product line.



### WICK BUILDINGS Booth 318/Circle 237

Wick Buildings is a leader in the post-frame industry, founded in 1954 and with more than 71,000 buildings completed. Wick builds everything—from industrial and light manufacturing facilities to banks and aviation buildings, from gas stations and churches to equine and livestock facilities to storage facilities. When you choose to become a Wick builder you'll have a building partner with corporate strength and a name you and your customers can trust.



### WORLD CLASS CORRUGATING Booth 624/Circle 238

World Class Corrugating has proven its ability to supply quality roofing and siding panels with service that is second to none. The knowledge and experience of the WCC team shows in its ability to understand and supply products and services needed for the post-frame and residential roofing markets. WCC is one of the few manufacturers that supplies painted siliconized polyester panels in either Galvalume or galvanized substrate.

*The building suppliers you can trust focus on*

# BUILDING STRONG RELATIONSHIPS.

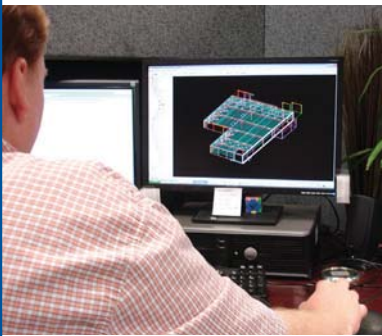

The most solid foundation upon which to build a partnership is trust. That's why, for more than 60 years, Varco Pruden has focused on creating relationships that last.

Our interest is always your best interest. While we offer decades of experience and expertise, constantly educating ourselves on your environment and consumers, we also take pride in our loyalty and value our credibility. You can depend on us to work for you. Because we're not just reliable, we're dedicated. And we never compete against our builder partners.

We offer superior products and service, including:

- ◆ Unrivaled quality
- ◆ Cutting-edge technology and innovation
- ◆ Unequaled marketing tools and resources
- ◆ A wide array of products
- ◆ Experienced project management and field support

Contact Varco Pruden today. Let us show you how, together, we can add value to your business and your reputation.



**BECOME AN AUTHORIZED VARCO PRUDEN BUILDER TODAY.**

Call 1-866-538-0012 or log on to [www.VP.com/ad/RBM](http://www.VP.com/ad/RBM).

Circle Reader Service #301

## industry news

BY RURAL BUILDER STAFF



## 2015 NDS and SDPWS standards approved by ANSI

The American Wood Council 2015 "National Design Specification for Wood Construction" and "Special Design Provisions for Wind and Seismic" standards have been approved by the American National Standards Institute.

Updated standards are available in electronic format on the AWC website. Print versions of the standards are expected to be available for purchase in early 2015. Primary changes to these standards are:

► **2015 NDS** – A new product design chapter for cross-laminated timber includes the design of CLT members, connections and fire design. Another significant change is new provisions that explicitly permit Structural Composite Lumber to be designed for fire requirements using NDS Chapter 16. The 2015 NDS Supplement, packaged with the NDS, contains updated design values for visually-graded southern pine and mixed southern pine dimension lumber.

► **2015 SDPWS** – New provisions have been added for seismic and wind design of cantilevered wood-frame diaphragms that provide important design clarifications, especially for design of "corridor-only" multi-story wood-frame structures. There are also revisions to the protocol for determining equivalent deformation-based shear distributions that allow more efficient seismic design of shear walls containing high aspect ratio shear walls.



## TITANIUM TOOLS

NEW!  
STAINLESS STEEL  
Nail Puller & Prybar



TiBone 15  
milled/curved

12" Stainless  
ClawBar w/ Dimpler

15" Stainless  
Flatbar w/ staple puller

10X LESS RECOIL  
HALF THE WEIGHT  
MORE PRODUCTIVITY

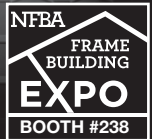

[www.stiletto.com](http://www.stiletto.com)

(800) 987-1849

Circle Reader Service #557

## TIRED OF OLD SCHOOL ESTIMATING?



## INCREASE SALES A BETTER WAY!

Construction  
**Maestro**<sup>®</sup>

POST FRAME & STUD FRAME ESTIMATING SOFTWARE

VISIT US AT BOOTH # 104

AND SEE THE ALL NEW 5.0

NFBA EXPO DISCOUNT PRICING!  
FAST. EASY TO USE. PROFESSIONAL RESULTS.

888-220-6230 [WWW.SYMUN.COM](http://WWW.SYMUN.COM)

Circle Reader Service #445

# Taking the Expo by storm

Tips for getting the most out of the Frame Building Expo

**IT HAS BEEN MORE THAN A COUPLE OF YEARS SINCE I ATTENDED MY FIRST, WHAT IS NOW, FRAME BUILDING EXPO.** For the gray beards amongst us, it was in Hershey, Pennsylvania. I've been to a few since, including exotic locations like Orlando and Phoenix and not as exotic, like Cincinnati below-zero degrees!

While some folks may look upon the Frame Building Expo as a welcome respite from the doldrums of winter or a tax deductible vacation, some advance preparation can make the event payoff a hundred fold.

**Important Tip Number One** – don't go alone. Certainly one could go solo, however to get the most possible out of the Expo, having a good team pays huge dividends. There is just too much going on to try to take it all in by yourself.

Who to bring on your team? If your spouse is active in the business, better bring them. If they are not an active participant in the business, it is best to leave them at home. You want to maximize your time and not have to be entertaining a spouse. Business partners, active management people, or others on your staff who will be with you for the long haul make ideal participants. These folks understand the value to be gained from being an Expo participant and the trip makes for a good reward to those who work hard.

I've brought sales persons as well as crew chiefs (when I was a builder). Personally I would now think long and hard about repeating either again, as for the great majority it was perceived as an expenses-paid vacation, rather than as a learning experience.

Once the core group has been decided upon, it is time to build the "game plan". Think of yourself as being the quarterback—call the plays which will maximize the coverage of the event, with the right people in the right place and your team will score touchdowns!

**Important Tip Number Two** – only bring staff who will take excellent notes and share with the rest of the group.

Check the content of any Special Workshops being offered. Make sure to get the right person to the right workshop, having a sales-oriented person at a safety workshop may not be the best fit. Workshop hours may also overlap other presentations or trade show time, so be prepared with sufficient people power to cover everything which needs to be seen.

Educational sessions should also be scoped out in advance. Get one team member to each session

which is relevant to your business. One single nugget gleaned from an educational session can more than pay for the entire trip.

We all have our favorite vendors who we dearly love. The trade show floor is not the place to spend hours patting each other on the back. Instead, use the time to pick the brains of those who are not your primary suppliers. You know what your current supplier can do for you, as well as their product line—this is the time to explore and to pick the brains of those you are less familiar with.

**Important Trade Show Floor Tips** – do not drag your entire team with you like an entourage. Encourage each of them to explore on their own. While each team member may very well visit any given exhibitor, chances are good they will speak to a different person manning the booth, or connect in a fashion to have gained different information. Start each day in the back and work towards the front, to avoid crowds.

Try to at least make a cursory visit to every booth before the last day. Plan the last day to laser focus on the new suppliers which are of greatest interest to you and can best help to grow your business. The last hour of the last day is always the best time to get undivided attention. Reserve the most important new contact for then.

After hours...is when the serious money gets made. If attending hospitality events, split the team up and have them meet and talk to as many folks as possible. Seek out those from other parts of the country who do what you do, and ask them how they do it. Find out what makes them successful as well as their challenges—and share with them in return.

The most valuable tip is to not run out of town the minute the show is over. Gather up the team for supper the evening after the Expo, have them all bring their notes and be prepared for discussion. Talk about what was learned and determine if there are benefits to implementing a new strategy or adding new products. What would it take to make each individual change in time, effort and costs, as well as what would the expected benefits be.

Prioritize from this after-show debriefing session, determine who will be responsible for each item to be implemented, as well as a time frame for completion. If any portion is long term, develop a regular reporting system to monitor the progress.

Make this and every future Frame Building Expo a part of your springboard to success!

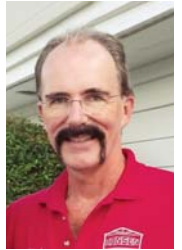

Mike Momb is technical director for Hansen Pole Buildings, LLC of Browns Valley, Minn. His daily post-frame blog, as well as his weekly "Ask the Pole Barn Guru" column can be followed at [www.hansenpolebuildings.com/blog/](http://www.hansenpolebuildings.com/blog/).



## Tip

The most valuable tip is to not run out of town the minute the show is over.

The One Event for Metal Construction  
Products, Technologies & Solutions  
[www.metalcon.com](http://www.metalcon.com)

25<sup>th</sup>  
**METALCON**

October 14 - 16, 2015

Tampa Convention Center

Tampa, Florida

SPONSORED BY  PRODUCED BY **PSMJ**

Circle Reader Service #331



Looking for more information from companies featured in this issue?

Use the Reader Service card between 58-59 to get **FREE** information from our advertisers!

Free online info at [www.bit.ly/info-rbfn](http://www.bit.ly/info-rbfn)

### ADVERTISERS

RS #	Company	Page #	RS #	Company	Page #	RS #	Company	Page #
334	A J Manufacturing, Inc	16	512	I Beam Sliding Doors	44	382	Rigidply Rafters	25
291	AB Martin	27	521	Lantor BV	46	408	Ritchie Industries	4
459	Akzonobel	29	341	Leland Industries	38	449	Rosko Fasteners	72
324	Anco Products Inc	12	392	Levi's Building Components	21	414	Schweiss Doors	32,71
328	Atlas Bolt & Screw	20	355	Marco Industries	68	429	Sealtite Building Fasteners	47
441	Aztec Washer Co	30		Marion Manufacturing	71	454	Semmler Systems Inc	52
569	Ameripak Inc	50	306	Maze Nails Company	75	523	Sheltercraft	63
338	Becker Specialty Corp	35	422	McElroy Metal Inc	11	482	Sno Gem, Inc	20
276	Bluelinx	14		Merrick Machine Co	71	540	Spectrum Brands HHI	7
435	Bradbury Group, The	31	282	Metal Coaters/Metal Prep	69	375	Starwood Rafters Inc	52
386	Cannonball:HNP LLC	19	584	Metal Rollforming Systems	46, 71	557	Stiletto Tools	55
553	CHI Overhead Doors	30	331	METALCON	57	472	Swenson Shear	70
531	Cidan Machinery Inc	32	412	MFM Building Products Corp	51	445	Symun Sys./Construct. Maestro	55
	Clark Industries	71	308	MWI Components	9	523	Sheltercraft	63
530	Direct Metals Inc	53	378	National Frame Building Assn	43,61	570	Timber Tech Engineering Inc	70
581	Dura Coat	37	463	Nationwide Protective Coating Mfrs Inc	64	576	Tri-State Lumber Company	49
316	Dynamic Fastener	13	290	Novagard Solutions	48	425	Triangle Fastener Corp	33
364	EDCO Products, Inc	39	516	Paint Valley Parts, LTD	45	600	TVM Building Products	48
407	EVERLAST Roofing Inc	76	350	Palram Americas	67	564	United Steel Supply	41
	Extrutech Plastics	71	313	Plyco Corporation	2	529	Valley Lumber	63
393	Fabral	22, 23	399	Precoat Metals	73	484	Valspar Corporation	5
384	Filc USA LLC	40		Power Lift Hydraulic Doors	71	301	VP Buildings Inc	54
433	Graber Post Buildings	65	503	Replications Unlimited	62	374	Western Products of Indiana	24
538	Hormann LLC	44		Ridge Craft	71	511	WICK Buildings	17
536	Hershey's Metal Meister	34						

EXPO 2014



## STORY RESOURCES

RS #	Company	Page #	RS #	Company	Page #	RS #	Company	Page #
<b>TOP 10 PRODUCTS OF 2014</b>								
100	PLYCO.....	6	151	EXTRUTECH PLASTICS INC.....	34	200	PLASTI-SLEEVE.....	45
101	CANNONBALL:HNP.....	6	152	FABRAL.....	35	201	PLYCO CORPORATION.....	46
102	DYNAMIC FASTENER.....	8	153	FASCO AMERICA.....	35, 66	202	POST PROTECTOR.....	46
103	MWI COMPONENTS.....	8	154	FASTENERS DIRECT.....	35	203	POWER LIFT DOORS.....	46
104	AJ MANUFACTURING.....	8	155	FILC USA.....	35	204	PPG INDUSTRIES.....	46
105	SNO GEM.....	8	156	FLAGPOLES BY UNCOMMON.....	36	205	PRECOAT METALS.....	47
106	LEVI'S BUILDING COMPONENTS.....	10	157	GRABER POST BUILDINGS.....	36	206	PROGRESSIVE METALS INC.....	47
107	GRABER POST.....	10	158	H & H METAL PRODUCTS.....	36	207	PROPEL SLIDING DOOR.....	47
108	SNOBLOX-SNOJAX.....	10	159	HERSHEY'S METAL MEISTER.....	36	208	RADIANT OUTFITTERS.....	47
109	PALRAM.....	10	160	HIAB USA, INC.....	36	209	REPLICATIONS UNLIMITED.....	48
<b>TOP E-PRODUCTS OF 2014</b>								
115	LELAND INDUSTRIES.....	24	161	HOOVER TREATED WOOD.....	36	210	RICHLAND LAMINATED.....	48
116	WICK BUILDINGS.....	25	162	HÖRMANN LLC.....	36, 62	211	RIGIDPLY RAFTERS.....	48
117	TVM INDUSTRIES.....	25	163	I-BEAM SLIDING DOORS.....	36	212	S-5!.....	49
<b>FRAME BUILDING EXPO EXHIBITORS</b>								
120	3GM STEEL INC.....	26	164	INDIANA WARM FLOORS.....	36	213	SAFE-WAY GARAGE DOOR.....	49
121	A J MANUFACTURING INC.....	26	165	INTEGRITY METALS.....	36	214	SCHWEISS DOORS.....	49
122	A.B. MARTIN ROOFING SUPPLY.....	26	166	JANUS INTERNATIONAL.....	36	215	SEALTITE.....	49
123	ADMIRALS BANK.....	26	167	KENWOOD PAINTED METALS.....	38	216	SEMMLER SYSTEMS INC.....	49
124	AMERIPAK STRETCH WRAP.....	28	168	KLOECKNER BUILDING PROD.....	38	217	SEWARD ASSOCIATES.....	50
125	ABC.....	28, 60	169	LANTOR BV.....	38	218	SFS INTEC.....	50
126	AKZONOBEL.....	28	170	LELAND INDUSTRIES.....	38	219	SIMPSON STRONG-TIE.....	50, 64
127	ANCO PRODUCTS INC.....	28	171	LESTER BUILDING SYSTEMS.....	39	220	STEEL DYNAMICS INC.....	50
128	APPLICAD-USA INC.....	28	172	LEVI'S BLDG COMPONENTS.....	39, 63	221	STILETTO TOOLS.....	50
129	ARCH WOOD PROTECTION.....	28, 60	173	LIBERTY STEEL INC.....	39	222	SWENSON SHEAR.....	50
130	ASC MACHINE TOOLS INC.....	28	174	MAC METAL SALES INC.....	40, 66	223	SYMUN SYSTEMS.....	51, 65
131	ATLAS FASTENERS.....	30	175	MARCO INDUSTRIES.....	40	224	TAYLOR STEEL.....	51
132	BAY INSULATION CO.....	30	176	MARION MANUFACTURING.....	40	225	TIMBER TECH ENGINEERING.....	51
133	BECK AUTOMATION.....	30	177	MARTIN BUILDING PRODUCTS.....	40	226	TRIANGLE FASTENER.....	51, 66
134	BECKER SPECIALTY.....	30	178	MAZE NAILS.....	41	227	TRI-STATE LUMBER CO.....	52
135	BESTLINE BUILDING PROD.....	31	179	MCELROY METAL INC.....	41	228	TRITON BARN SYSTEMS.....	52
136	BOTKIN LUMBER CO.....	31	180	MENARDS INC.....	41	229	TVM INDUSTRIES.....	52
137	BRADBURY GROUP.....	31, 60	181	METAL ROLLFORMING SYS.....	42, 63	230	UNION CORRUGATING.....	52
138	BRUT POST GRABBER.....	31	182	METAL SALES MFG.....	42	231	UNITED STEEL SUPPLY.....	52
139	BURROW'S SUPPLY.....	31	183	METALFORMING INC.....	42	232	UNIVERSAL FOREST PROD.....	53
140	CANNONBALL:HNP.....	32	184	MILL STEEL CO.....	42	233	VALLEY LUMBER.....	53
141	CENTRAL STATES MFG.....	32	185	MSW CANADIAN PLASTICS.....	42	234	VALSPAR CORPORATION.....	53, 65
142	C.H.I. OVERHEAD DOORS.....	32	186	MWI COMPONENTS.....	42	235	WAYNE DALTON.....	53
143	CIDAN MACHINERY INC.....	33	187	NATIONAL HARDWARE.....	42	236	WESTERN PRODUCTS.....	54
144	CLARK INDUSTRIES INC.....	33	188	NEW PROCESS STEEL CORP.....	42	237	WICK BUILDINGS.....	54
145	DIRECT METALS INC.....	33	189	NOFP INC.....	42	238	WORLD CLASS CORRUGATING.....	54
146	DURA COAT.....	33	190	NORTH STAR METALS MFG.....	44	<b>SUPPLIER NEWS</b>		
147	EAGLE METAL PRODUCTS.....	34	191	NOVAGARD SOLUTIONS.....	44	260	NUDO.....	68
148	EAST COAST FASTENERS.....	34	192	OFIC NORTH AMERICA.....	44	261	PALRAM.....	69
149	ENERGY PANEL STRUCTURES.....	34	193	OHIO TIMBERLAND PROD.....	44	262	ABC SEAMLESS.....	69
150	EVERLAST ROOFING INC.....	34	194	PACESETTER STEEL SERVICE.....	45	263	TRIANGLE FASTENER.....	69
			195	PAINT VALLEY PARTS LTD.....	45	264	SIMPSON STRONG-TIE.....	70
			196	PALRAM AMERICAS.....	45, 62			
			197	PARAMOUNT METALS.....	45			
			198	PERMA-COLUMN INC.....	45, 64			
			199	PLANET SAVER.....	45			

*The index is provided as a reader service. Occasional last-minute changes may result in ads or editorial copy appearing on pages other than those listed here. The publisher assumes no liability for omission or errors.*

## new products at the expo

BY RURAL BUILDER STAFF

# Products making their Expo debut

Options for post-frame builders just keep getting better



### AMERICAN BUILDING COMPONENTS

#### Commodity Panel Line

Ideal for barns and storage projects, the Commodity panel line provides great value paired with the unparalleled quality you've come to expect from ABC. The Rustic Trail panel offers a unique look and feel with rich traditional oxidized rust color, an ideal solution for post-frame projects. ABC has also added three new commodity panel colors with vintage white, radiant red and clay. **For more information circle 125.**



## visit us

The staff of *Rural Builder* and *Frame Building News* will be at the Expo. **Visit us at Booth #249.**



### THE BRADBURY CO. INC.

#### The Mini-B.O.S.S. Flying Shear

The Bradbury Co. Inc. is pleased to introduce 24 inch and 36 inch wide Mini-B.O.S.S. Flying Shears to complement its existing 48-inch model. The 24-inch model is ideal for trim roll-forming lines or standing seam lines while the 36 inch can be used for narrow panel lines such as corrugated and 5V panels. Its servo acceleration and closed loop controls provide +/- 1/16-inch length tolerance at any speed up to 200 feet per minute. The B.O.S.S. shear does not require a conveyor for part separation, making it ideal for upgrades or retrofits to existing equipment. **For more information circle 137.**

### ARCH WOOD PROTECTION

#### BARamine technology

Arch Wood Protection recently introduced an additive for treated wood that provides enhanced defense against common fungi as well as against certain aggressive rogue fungi that can tolerate commonly-used residential preservative systems on the market. BARamine technology, for which a worldwide patent is pending, is being incorporated into the treatment of Wolmanized Outdoor Wood, the production of which is licensed by Arch Wood Protection. **For more information circle 129.**

# Calling All Post-Frame BUILDERS!

# Calling All Post-Frame SUPPLIERS!



**NFBA**  
NATIONAL FRAME BUILDING ASSOCIATION



## Enjoy the value of NFBA membership and hold your own among your peers.

NFBA membership provides building professionals with *must-have* networking opportunities, technical and marketing resources, and industry news.

### I'm a BUILDER.

What NFBA offerings are specifically for builders?

- Leads through the [nfba.org](http://nfba.org) and [postframeadvantage.com](http://postframeadvantage.com) "Find a Builder" directories
- A listing in the *Frame Building News* directory of builders
- Free technical advice from post-frame experts
- Free safety and legal advice from NFBA's legal counsel
- Accredited Post-Frame Builder program
- Safety review and recognition program for builders
- Building of the Year Awards program
- *OSHA Compliance Guide*
- Access to building code e-library
- Frame Building Expo attendee discounts

### I'm a SUPPLIER.

What NFBA offerings are specifically for suppliers?

- Leads through the [nfba.org](http://nfba.org) "Supplier Marketplace" directory
- A listing in the *Frame Building News* directory of suppliers
- Free technical, safety, and legal advice
- Safety review and recognition program for suppliers
- Inside knowledge and forecasts on post-frame products
- Frame Building Expo exhibitor discounts

Visit [nfba.org](http://nfba.org), e-mail [info@nfba.org](mailto:info@nfba.org),  
or call 800.557.6957 to join and learn more.

## new products at the expo

BY RURAL BUILDER STAFF



### HÖRMANN

#### TimberLast Finish Doors

Hörmann is introducing a new and unique line of doors that offer the durability of steel with the elegant look of natural wood. The Orion 3110/3210 collection with TimberLast finish comes standard with Hörmann's exclusive FingerGuard pinch resistant section joints for both the interior and exterior, a choice of either 1-inch or 2-inch thick galvanized and finish painted steel sections, durable steel front and back three-layer sandwich construction insulated with expanded polystyrene. **For more information circle 162.**

### PALRAM AMERICAS

#### MetalMatch technology

Palram continues to expand its SunSky polycarbonate panel line, allowing builders to offer more day lighting and side lighting options to customers. With Palram's new MetalMatch Technology, it can match virtually any corrugated metal panel profile available with minimal order requirements. Palram also offers a complete line of Ag-Tuf PVC liner panels for interior and exterior use. **For more information circle 196.**



### PRE-ENGINEERED FAUX STONE PANELS



4 Styles & multiple colors available



for more info and samples contact  
us at 314-524-2040

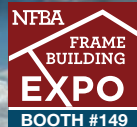

- Single piece 8 foot long wainscot stone panels with built-in ledger
- Lightweight System - no footing or support beam required
- Simple low cost installation
- High quality coloring, depth and appearance
- Matching column kits available
- High R-Value (5-6)
- Low maintenance

[www.urestonepanels.com](http://www.urestonepanels.com)

Circle Reader Service #503

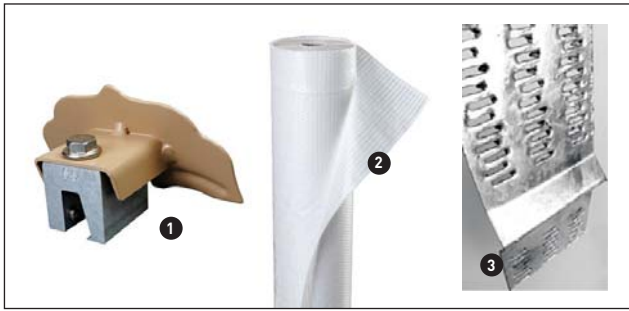

## LEVI'S BUILDING COMPONENTS

### 55RF Snow Defender, Metal Wrap, and Hot Dipped Galvanized Uplift Plate

Levi's Building Components will be showing off three new products at the Expo: the 55RF Snow Defender snow guard; woven polypropylene Metal Wrap for roofing; and its innovative Uplift Plate system now in an IBC approved hot dipped galvanized version.

**1 55RF Snow Defender:** The 55RF Snow Defender is designed to take the frustration out of aligning on standing seam. It combines the durability of the Snow Defender series with the versatility of the S-5 clamp systems to adapt quickly. The 55RF comes in 30-plus color finishes and fits with multiple S-5 clamps (N, U, S and V).

**2 Levi's Metal Wrap:** Levi's new woven polypropylene Metal Wrap product is designed to provide a temporary weather resistant barrier between the elements and a builder's metal roofing project. Metal Wrap is lightweight and easy to install as well as highly tear resistant. Your company logo can be imprinted at no extra charge.

**3 Hot dipped galvanized coated Uplift Plate:** Levi's innovative Uplift Plate system is designed to help the post-frame builder save time and money in the field. Now available in an IBC-approved hot dipped galvanized version, Levi's makes this Uplift Plate product even more suitable for all types of building projects. Ideal for underground application, the Uplift Plate is easy to install and stronger than rebar.

For more information from Levi's circle 172.



## METAL ROLLFORMING SYSTEMS

### Patriot Rollforming Line

Metal Rollforming Systems is introducing the new Patriot Rollforming Line. The Patriot's integrated shear and modular die-set cartridge is capable of producing many different profiles on one single machine. The versatility of the Patriot Line is not just limited to the panel design, it can be reconstructed into a slit to recoil line as well. Because all equipment is designed and manufactured in-house, MRS offers very competitive pricing. For more information circle 181.

# ULTRALAM

*When strength counts!*

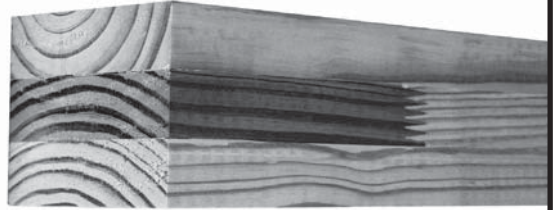

- ULTRALAM is an all glue structural framing column for vertical applications
- #1 southern pine upper Finger jointed to kiln dried, .60 CCA treated #1 southern pine lower
- 50' lengths are available.



800-553-0661 | valleylb@hotmail.com  
valleylumbercompany.com

Circle Reader Service #529

935 N 275 W Suite B  
Angola, IN 46703

**Indiana Warm Floors**  
Efficient for Life

SHELTER CRAFT SUPPLY

Snow Melt Systems  
Radiant Heat  
Geothermal  
Tankless Hot Water

## Radiant Floor Heat!

- Warm, Silent & Efficient
- Hot Water or Electric
- Tankless Hot Water
- Slabs
- Wood Floors
- Geothermal
- Wood Boilers

Heated Floor Before

Heated Floor After

See us at [www.indianawarmfloors.com](http://www.indianawarmfloors.com)  
260-668-8836 • 800-700-8830

Circle Reader Service #523

## new products at the expo

BY RURAL BUILDER STAFF

### PERMA-COLUMN

#### SW60 Universal Brackets

In response to customer requests, Perma-Column now offers a new drill-set bracket that accommodates 4 inches or wider posts and three-ply laminated columns.

Two SW60 Universal brackets on adjacent sides of a post are often used so the anchor flange does not stick out of a corner or into a doorway. Because the SW60 is 5 inches wide, it is a bit larger than 3-ply laminated columns. To affix two SW60 universal brackets to a laminated column the common practice is to turn one SW60 backwards and place it under the laminated column so it does not stick out of the corner of the building or into a doorway.

To provide another option for 3-ply columns and posts 4 inches or wider, the new SW6C was developed to work with 3-ply laminated columns in corners and doorways within the wall.

The new SW6C drill-set bracket is 4 inches wide to better fit against the plies of laminated columns and smaller posts. **For more information circle 198.**

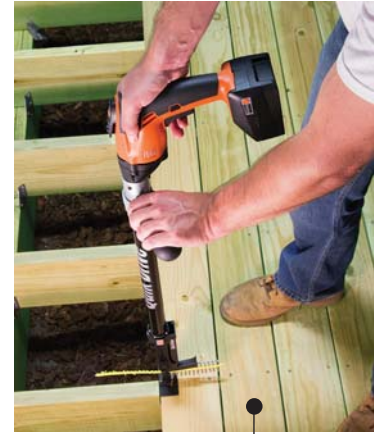
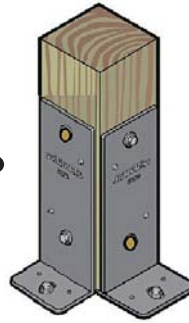

### SIMPSON STRONG-TIE

#### FEIN ASCS6.3 motor for Quik Drive Systems

Simpson Strong-Tie now offers the FEIN ASCS6.3 motor for use with all Quik Drive Auto-Feed Screw Driving Systems; making this the most versatile cordless auto-feed screw driving solution on the market. Quik Drive systems with the FEIN cordless driver offer superior performance and reliability to keep you working faster for years to come. **For more information circle 219.**



**100% ACRYLIC** **EXCELLENT MILDEW RESISTANCE**

# SHINGLE SEALER™

**RE-GLUES & SECURES LOOSE SHINGLE GRANULES**

**5 YEAR WARRANTY**

## WATERPROOFING CLEAR PROTECTORANT

**RESTORE, EXTEND, PRESERVE and REJUVENATE Your ROOF, Any ROOF**

**CALL TODAY FOR YOUR FREE SALES & MARKETING KIT!**

**NATIONWIDE PROTECTIVE COATING MANUFACTURERS, INC.**  
www.nationwidecoatings.com

SARASOTA - FLORIDA  
ACCREDITED BUSINESS  
BBB A+ RATING  
Member Since 1997

Over 100 GREEN SAFE PRODUCTS including CERAMIC PAINTS, ROOF & WALL COATINGS and MANY OTHER QUALITY PRODUCTS

1.800.423.7264 941.753.7500

Circle Reader Service #463

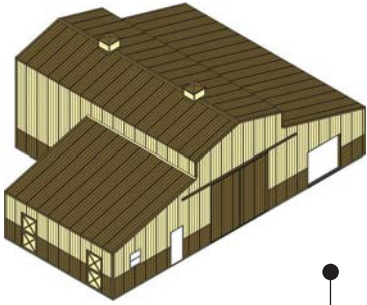

**SYMUN SYSTEMS**

**Construction Maestro Version 5**

Symun Systems' newest version of its software will be available for review at the Expo. Construction Maestro Trio Version 5 estimating software (post frame, stud frame garages, and decks) streamlines the estimating process to create a complete set of plans and materials lists in a matter of minutes. This easy to use, customizable system is designed for lumber companies and building contractors alike. Take advantage of a preloaded product database containing nearly 50,000 products from 70 of the industry's leading vendors. Create and promote package sales with custom templates. A 20-day fully functioning trial is available upon request. **For more information circle 223.**



**VALSPAR**

**WeatherXL Crinkle Finish**

Valspar's WeatherXL Crinkle Finish coatings for coil applications deliver outstanding durability with a unique, textured appearance that redirects light for enhanced visual depth. Designed to create a shifting and shimmering effect, WeatherXL Crinkle finish is available in a number of color options that meet solar reflectivity (SR) standards for LEED and Energy Star. The coating's silicone polyester resin system offers maximum hardness and unrivaled performance against chalking, fading and scratching. **For more information circle 234.**

GRABER POST IS HOSTING A RECEPTION AT THE 2015 FRAME BUILDING EXPO

# GRABER POST HOSPITALITY

*Reception*  
"FEATURING WILL STOLTZ"

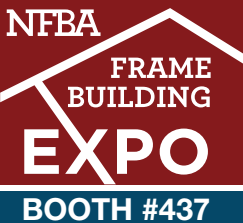

**THURSDAY FEBRUARY 19TH**  
**SALON BALLROOM**  
**8:00-12:00 PM**  
**DRINKS, HORS D'OEUVRES LIVE MUSIC**

**7716 N. 900 E. Montgomery, Indiana 47558**  
**800-264-5013 | Fax 812-636-4936**  
**www.graberpost.com**



Circle Reader Service #433

## new products at the expo

BY RURAL BUILDER STAFF



### TRIANGLE FASTENER CORPORATION Burr-Buster self-piercing screws

Ordinary self-piercing screws produce burrs during installation that can damage surface and corrode quickly. Triangle Fastener's Burr-Buster Technology produces less burrs compared to ordinary self-piercing screws. The proprietary dual thread was designed to penetrate steel up to 2x20 gauge faster with less chips than ordinary self-piercing screws. The screws are provided with Tri-Seal 1,000 hour salt spray coating for superior corrosion protection.

### APS 500 Advanced Polymer Sealant

TFC is also introducing APS 500 Advanced Polymer Sealant. APS 500 is formulated for superior adhesion, excellent resistance to weathering and is compatible for use with a variety of substrates. The sealant comes in plastic "job site friendly" tubes and combines the strength of polyurethanes with the weathering resistance of silicones, installing at temperatures from -35F to 140F and available in custom colors. **For more information from TFC circle 226.**

### FASCO AMERICA Jumbo Nails

Fasco America offers a full range of Jumbo Nails and two well-designed tool models to conquer your BIG timber framing jobs. These tools have a side handle for extra support while driving the Jumbo Nails. Jumbo Nails are available in 4 inch to 6-3/8 inch lengths and can be ordered in many different finishes, shank deformations, points, and collations to meet your exact needs. **For more information circle 153.**

### MAC METAL SALES INC. MAC Ultra steel panel

MAC Metal is pleased to introduce a new panel offering to its customers. MAC Ultra is a true 28-gauge, .0153-inch minimum steel panel that is available in 11 colors to service the post-frame industry. **For more information circle 174.**



## >>> Calendar of Events

# 02 /

## FEBRUARY

**18-20**, Frame Building Expo, Louisville

**24-26**, International Roofing Expo (IRE),  
New Orleans

# 03 /

## MARCH

**1-3**, National Ready Mixed Concrete  
Association Annual Convention, Orlando.

**18-20**, 96th Annual Associated General  
Contractors Convention,  
San Juan, Puerto Rico.

**22-24**, North American Lumber Association  
Leadership Summit, Scottsdale, Ariz.

**25-26**, North/East Roofing Contractors  
Association (NERCA), Mashantucket, Conn.

# 05 /

## MAY

**14-16**, American Institute of Architects (AIA)  
Convention 2015, Atlanta.

# 06 /

## JUNE

**14-17**, WSRCA (Western States Roofing  
Association), Expo, Las Vegas.

FEBRUARY SUPPLIER NEWS  
HIGHLIGHTS

**ABC Supply Acquisitions**  
P. 67

**Palram New logistics center** P. 68

**Valspar Coating the Netherlands** P. 70

**ABC Supply Co., Inc. acquires Siding World and Gilbert Supply assets**

ABC Supply Co., Inc. continues on its road to major expansion, most recently acquiring the assets of Siding World and Wameling.

Siding World is a distributor of siding and other exterior building products including roofing, windows, doors, decking and gutters. The 40-year-old company has locations in 17 markets in Michigan, Indiana and Ohio. They will join 15 existing ABC Supply branches in Michigan, 13 in Ohio and eight in Indiana.

All of the Siding World branch associates are remaining with the organization.

Siding World's Michigan stores are in Battle Creek, Chesterfield, Clio, Detroit, Fenton, Inkster, Jackson, Kalamazoo, Livonia, Madison Heights, Saginaw, Sanford, Waterford and Wyandotte. There are two locations in Indiana – South Bend and Goshen – and one in Toledo, Ohio.

ABC Supply also recently acquired the assets of Wameling Drywall Corp. (doing business as Gilbert Supply Company), a single-location distributor of exterior building products, wallboard and insulation, in Marcy, New York.

Tom Kuchan, vice president of ABC Supply's Northeast Region, explained the reasons for the New York acquisition. "The Utica/Marcy area is poised for growth," he said citing the Nano Utica initiative, a public-private partnership that is expected to bring more than 1,000 high-tech jobs to the area and help create New York's second major hub of nanotechnology research and development. "We look forward to being part of that growth by serving the area's residential and commercial contractors."

Customers will continue to work with the Gilbert Supply team. Anthony Wameling, president and co-owner of the former Gilbert Supply is joining ABC Supply. Vincent Conley, vice president and co-owner of the former Gilbert Supply, has retired.

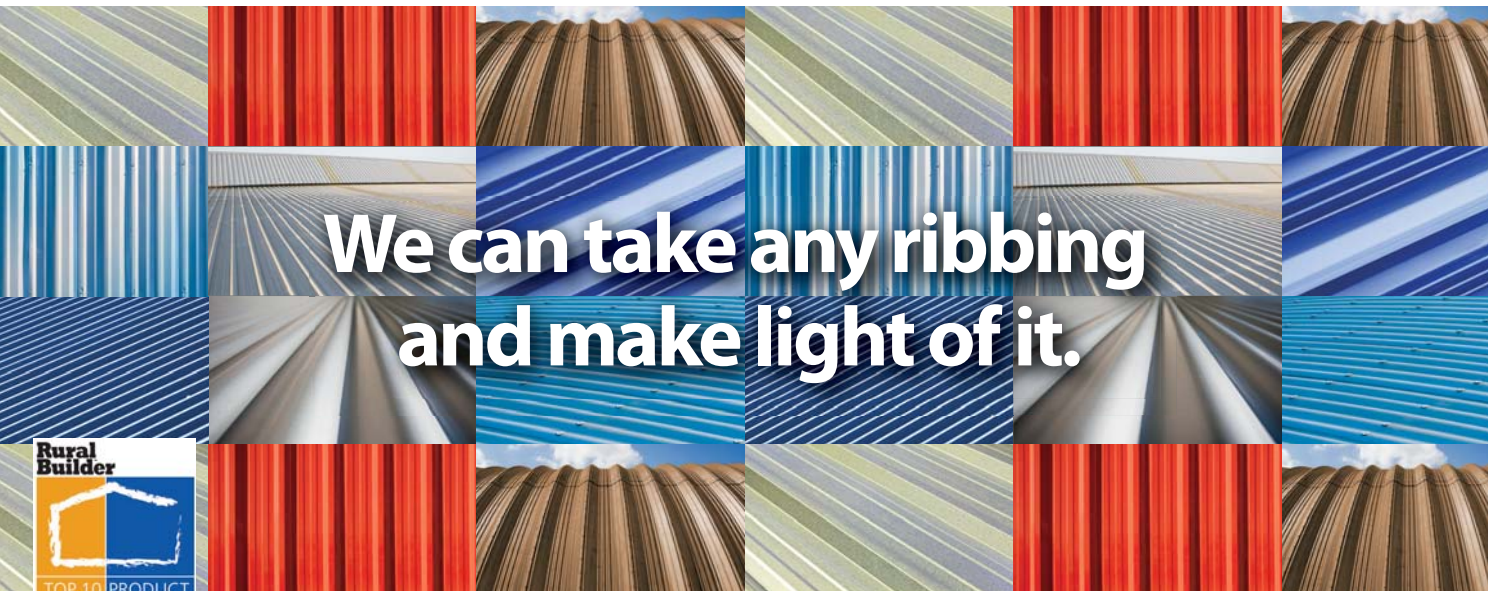

We can take any ribbing  
and make light of it.



**Match virtually any custom profile with SunSky in days.**

Get the leading corrugated polycarbonate delivered fast to fit most any metal profile with SunSky® MetalMatch™ technology. So you can add value and more daylight to projects in as little as two weeks. And MetalMatch is available at an extremely attractive price.



**More daylighting options. More easily.**

SunSky's first-in-class durability, high performance and superior light transmission are ideal for roof, side and skylight applications. So you can expand unique design possibilities, reduce energy costs, and enhance environments with more natural light. Available in several opacities,



including Soft White, SunSky is backed by a 10-year warranty. To learn more, contact your local distributor or call 800-999-9459. Or visit us at [www.PalramAmericas.com/MyProfile](http://www.PalramAmericas.com/MyProfile). We'll take the perfect ribbing and make it even better.

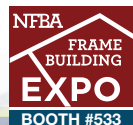

Circle Reader Service #350

## supplier news

BY RURAL BUILDER STAFF

### ■ Nudo launches high impact hurricane panel

Nudo Products, Inc. has launched Endurex 555, a high impact hurricane panel. Instead of using steel to provide impact protection, Nudo has engineered a lightweight, super-strong composite material.

Although lighter and much easier to cut and install, the Endurex 555 panel passed all national “hurricane” testing requirements and meets the Miami Dade testing requirements.

For more information on Endurex 555 circle 260.



### ▲ Palram Opens New Logistics Center

Palram Americas has announced the completion of an 80,000 square foot logistics center positioned directly next door to its Americas headquarters in Weisenberg Township, Kutztown, Pennsylvania.

“We did run into some issues due to the harsh winter of 2013, resulting in a delayed opening,” stated John Seiffert, Vice President of Business Development for Palram Americas. “However, now that the building is operational, we are confident this dedicated logistics center will greatly increase our delivery capabilities and result in greater customer satisfaction.”

The 80,000 square foot building is a \$5 million construction project with two phases. Phase one consisted of this logistics center and includes an additional 80,000 square feet of outside storage space. An additional 80,000 square foot building will be constructed during phase two and will be built in the near future. The general contractor for phase one was Serfass Construction of Allentown, Pennsylvania.

This new logistics center is just the latest building block of growth for the company. Palram opened its polycarbonate plant in Kutztown in 2000 and, over the ensuing years, built two large additions to this original plant. In 2007, Palram constructed an entire PVC manufacturing facility at the site. The logistics center, completed in November 2014, is now fully operational.

Here's the easiest

# \$50

you'll ever make.

Going to the Frame Building Expo?

See us at **Booth #139** and you could win \$50.

*Here's how:*

- 1 Get a sticker at our booth
- 2 Wear it while you're at the show
- 3 We'll roam the floor randomly handing out \$50 bills to people we see wearing our sticker—we'll have a winner every hour, every day of the show!

The best metal roofing ventilation products available.  
Plus, a chance to win \$50! Only from Marco.



marcoindustries.com

©2015 Marco Industries

Circle Reader Service #355



An overhead view of the new Palram logistics center in Kutztown, Pennsylvania.  
Palram photo

## Palram partners with Snaveley Forest Products to distribute Palight Trimboard

Palram Americas has partnered with Snaveley Forest Products to offer the full line of Palight Trimboard products. Snaveley is a recognized distribution leader in the wholesale lumber and building products industry serving the Mid-Atlantic region.

Clark Spitzer, VP Marketing of Snaveley stated, "We look forward to leveraging Palram's production expertise together with Snaveley's market presence and understanding."

For more information on Palight circle 261.

## ABC Seamless introduces horizontal seamless steel roof

ABC Seamless has introduced a revolutionary concept in permanent metal roofing – the exclusive Horizontal Seamless Steel Roof that looks like shingles. And its portable roll-forming system lets installers manufacture the product on site.

To date, ABC Seamless has installed enough seamless steel products to circle the world three times. They have also never discontinued a style or color.

For more information on Horizontal Seamless Steel Roof circle 262.

## Triangle Fastener launches product video for VRT Technology

TFC has launched a new product video for VRT Technology, their patented screw thread designed to increase back-out resistance of screws used in thin metal connections.

You can view the video on their YouTube channel home page, listed under Triangle Fastener Corporation.

For more information on VRT Technology circle 263.



# PRIME PARTNERSHIP

*Prep Your Future.*

**Prime Partnership** means having a supply chain partner who can contribute to your success by providing you with superior customer service, unrivaled quality, and the most diverse selection of coil coated hot rolled steel products available to the market. Prime Partnership also means having a supply chain relationship built upon mutual trust, reliability and value, allowing you to improve your productivity, reduce costs, lower inventory expenses, and eliminate environmental emissions while we focus on state-of-the-art coil coating techniques and providing you with the Prepainted Steel products you need.

METAL PREP®  
**PRIME ALL THE TIME**

Experience The Metal Prep Effect



Metal Prep Houston  
Houston, TX  
713-921-7997

Metal Prep Memphis  
Memphis, TN  
901-946-6100

[www.metal-prep.com](http://www.metal-prep.com)

Circle Reader Service #282



**PA East Office:**  
Denver, PA 17517  
Phone: 717-335-2750

**IN Office:**  
Kouts, IN 46347  
Phone: 219-766-2499

**Structural Engineering Service**

- Specializing in Structural Design of Post- Frame Buildings
- Structural Design of Wood, Steel, and Concrete Structures
  - Engineer Certifications for all States
    - CAD Drafting Services
    - Building Code Review

**Ag Engineering Service**

- Agricultural Building Design
- Manure Storage System Design
- TSP (Technical Service Provider) for NRCs Projects
  - CAFO and NPDES Permits
  - Farmstead Expansion Planning

Visit us at the NFBA Expo Booth #106

Web Site: [www.timbertecheng.com](http://www.timbertecheng.com) or E-mail Us At: [tte@timbertecheng.com](mailto:tte@timbertecheng.com)

Circle Reader Service #570

*Introducing the new*

# SNAPTABLE HD

**BETTER BUILT. MORE PRECISE CUT.**



NFBA FRAME BUILDING EXPO BOOTH #109

55<sup>th</sup> YEAR

SWENSON SHEAR EST. 1959 ANNIVERSARY

- Consistently hems, notches & slits!
- Jobsite transportable!
- Accommodates panels from 12"–22"
- Safety risk free!
- 2 year warranty!
- Discounted notcher plans!
- Custom brand powder coating available

+1 877.588.8748 • [sales@swensonshear.com](mailto:sales@swensonshear.com)

[www.swensonshear.com](http://www.swensonshear.com)

Circle Reader Service #472

## supplier news

BY RURAL BUILDER STAFF



### ▲ Valspar coatings help Markthal Rotterdam achieve vibrant indoor mural

Valspar coatings were used on a very unique mural project in the Netherlands. The large mural, adorning a 40-meter arched-shaped structure, was created on aluminum panels at the Markthal Rotterdam, the first indoor market and housing development in the Netherlands. It opened in October after five years of construction at a total estimated cost of more than \$213,000,000.

### ■ Simpson Strong-Tie CPTZ concealed post base named to This Old House Top 100

This Old House has named the Simpson Strong-Tie CPTZ concealed post base to its 4th annual "The TOH Top 100," a list of the 100 best new home products of the year.

The CPTZ concealed post base is designed to connect a wood post to concrete. It provides a clean, concealed look while providing a 1 inch standoff height above concrete. The 1" standoff reduces the potential for decay at the post end and satisfies code requirements for posts that are exposed to weather, water splash or in basements.

For more information on CPTZ circle 264.

### ■ Swenson Shear extends distribution through AMSI Supply

Swenson Shear has entered into a distribution agreement with AMSI Supply, Douglasville, Ga. The agreement took effect October 10, 2014.

Swenson Shear manufactures heavy duty metal panel cutting tools and all-in-one finishing tables for roofing and construction contractors.

With over 30 years of experience, AMSI specializes in fabrication and distribution for the metal roofing industry, including standing seam clips, snaplock clips, bearing plates, gutter hangers, etc.; and now the full Swenson Shear product line.

160 DOORS & WINDOWS

**New One-Piece** 800-746-8273

**DOORS** AG DOORS  
SHOP DOORS  
BARN DOORS  
AVIATION

Say YES... to Strap-Lift Doors  
Say NO to Cable Lift

**BOOTH #148**

**HYDRAULIC - OR - BIFOLD**  
"One-Piece" BOOR STRAP LIFT and auto latch

**SCHWEISSDOORS.com**

**Doors built for a lifetime.**

- Every Door Built, Delivered and Installed by Local Professionals
- Lifetime Structure Warranty
- Safe, Strong & Weathertight
- Zero Maintenance
- No Lost Headroom
- New or Existing Buildings



**POWERLIFT** HYDRAULIC DOORS™

NFBA FRAME BUILDING EXPO BOOTH #243

855-368-9595 www.powerliftdoors.com

175 HELP WANTED

**SALES MANAGER**

Manufacturing Co. building automated machines has immediate opening for aggressive experienced person with a construction background. Must know how to close, good with a computer, able to build a sales organization, travel, and have good communication skills.

Send resume to:  
c.d.smith@merrickmachine.com

400 ROLL FORMERS

**MARION MANUFACTURING**

- Automation Systems
- Metal Construction Rollformers
- Coil Processing
- Forming & Fabrication
- Recondition Existing Machines

NFBA FRAME BUILDING EXPO BOOTH #124

**WE ADD THE VALUE TO METAL**

1-888-865-8740 www.marionmanufacturing.com

250 MISCELLANEOUS

**ROYAL CROWNE** OUTDOOR ACCENTS

Check out our entire cupola collection at  
www.RoyalCrownCupolas.com

**717-355-2254**

**Extrutech FORM™ System**

Extrutech FORM™ System brings a bright new 6" thick by 24" inch wide face to stay-in-place concrete form construction by combining standard concrete form methods with the easy-to-clean, sanitary surface that Extrutech panels provide. Perfect for process area walls.

Suspended Ceiling Panels and Doors also Available

**NEW PRODUCT**

**888-818-0118**

**Epi** www.epiplastics.com email: info@epiplastics.com **USA**

Manufacturing American-Made PVC Panels for 22 Years! Booth 209

**EXTRUTECH PLASTICS, INC.**

400 ROLL FORMERS

**MRS** METAL ROLLFORMING SYSTEMS

The Affordable Rollforming Equipment Manufacturer

- Single & Double Deck Rollformers
- Trim Rollformers
- \*NEW\* Patriot Rollforming Line
- Coil Reels
- Precision Cut Slitting Lines
- Sheet Stackers
- Coil Upenders
- Ridge-Cap Press

NFBA FRAME BUILDING EXPO BOOTH #637

1.888.284.6794 www.mrsrollform.com

600 TOOLS/EQUIPMENT DISTRIBUTOR

**Clark Industries, Inc.**  
Since 1967 - Monett, Missouri

Considering equipment? Consider Clark.

NFBA FRAME BUILDING EXPO BOOTH #647

- Roof & Floor Truss Presses
- Multi-Head Truss Presses
- Modular Truss Presses
- Shuttle Presses
- Jack Presses
- H.D. Chord Splicers
- Post & Column Machines
- Floor Truss Machines
- Electric Horizontal Stackers
- Electric Peak-up Stackers
- Conveyor Systems
- Custom Machinery

Call us toll free at: 800.743.9727  
or visit us on the web at: www.clark-ind.com

**WHO ARE YOUR FAVORITE SUPPLIERS?**

**Rural Builder** magazine is looking for contractors to nominate their favorite manufacturers and distributors for the annual Rural Builder Gold Key Award. The awards are announced in the July issue of Rural Builder.

If you have a key manufacturer/distributor who provides you with the supplies you need, when you need them and with courteous, helpful service, let us know.

**CONTACT: Sharon Thatcher**, sharon.thatcher@fwcommunity.com, or Fax your choice(s) to Rural Builder at **715-445-4087**.

# The Tax Extenders

Tax Increase Prevention Act of 2014 extends incentives

**CONGRESS HAS PASSED AND THE PRESIDENT SIGNED INTO LAW THE TAX INCREASE PREVENTION ACT OF 2014, WHICH RETROACTIVELY EXTENDED FOR ONE YEAR SOME 54 EXPIRED TAX BREAKS.**

The so-called “tax extenders” effectively allow rural building businesses to claim a number of popular but temporary tax incentives on their 2014 tax returns filed in 2015.

Businesses big and small, commuters who use public transportation, teachers who spend their own money on classroom supplies, individuals who claim the state and local sales tax deduction, higher education tuition and people who live in states without state income taxes would have been denied these tax breaks without these one-year extensions.

Without the new law, builders and contractors would be unable to claim business and energy incentives such as bonus depreciation, Section 179 first-year expensing and the research tax credit, among others, were it not for the newly-minted law. Unfortunately, the Tax Increase Prevention Act does not make permanent any extenders—nor extend any of them for the usual two-year period that has been customary. Instead, under the new law, these extenders are for the 2014 tax year only.

The Tax Increase Prevention Act extends many previously-expired business tax incentives for one year such as:

**BUSINESS PROPERTY WRITE-OFFS:** Bonus depreciation has been extended, allowing an additional first year deduction of 50 percent of the cost of equip-

ment acquired during the 2014 tax year. With 50 percent bonus depreciation, a builder or contractor can deduct half the cost of new capital purchases in the first year.

Under Section 179 of the tax code, small businesses are allowed to deduct the cost of investments in business assets such as equipment, property and software at the time of purchase, rather than over many years, thus creating a more immediate tax windfall. In other words, Section 179 of the tax law allows a business to deduct the entire cost (100 percent) of up to \$500,000 of new or used computer equipment, heavy vehicles, fixtures, furniture—in fact, most depreciable assets with less than a 20-year life.

To some, the bonus depreciation break may be more valuable than the Section 179 break because the Section 179 expensing deduction is limited to the taxable income of the building business with any excess carried forward. Those actively involved in running a business can, however, not only claim losses generated by 50 percent bonus depreciation against other income but can also carry any still-unused losses back for two years and get a refund check from Uncle Sam.

And don't forget, a building business—or its customers may be able to use Section 179 expensing on qualified leasehold, retail improvement, and restaurant property that was placed in service by December 31, 2014. Of course, there's a limit of \$250,000 on qualifying property.

**NEW LIFE FOR LEASEHOLD IMPROVEMENTS:** In addition to the Section 179 first-year expensing



Mark Battersby has more than 35 years experience in small business issues, tax and financial matters. Contact him at 610-789-2480 or [MCBatt12@Earthlink.net](mailto:MCBatt12@Earthlink.net).

## Tax break

The so-called “tax extenders” effectively allow rural building businesses to claim a number of popular but temporary tax incentives on their 2014 tax returns filed in 2015.

We don't need a fancy color ad to show you another picture of a fastener.



Rosko Fasteners & Supply is here in Black and White to let you know our 20 year history of **exceptional Customer Service & Quality Control** are what make us stand above the rest. But don't take our word for it. **Read feedback from our customers:**

*"Since 1993, Rosko Fasteners has always fulfilled our orders in a timely and cost efficient manner; we would not even consider another vendor. If you need quality with integrity, call the Rosko boys." - John A.*

*"Rosko Fasteners consistent attention to quality and on-time delivery keeps our business coming back to their products. In 15 years of doing business together, Rosko Fasteners has never failed to meet our expectations. Rosko Fasteners provides quality products with exceptional customer service." - Chris A.*

*"I've purchased from Rosko for 14 years. I keep coming back because they appreciate my business, they are family owned, they provide prompt service, and they have great customer service. Rosko provides excellent material and is a grade A company!" - Tom C.*

**Rosko Fasteners & Supply, Inc.**  
(800) 404-6654  
[roskofasteners.com](http://roskofasteners.com)

Okay, we can't help ourselves. One picture of our Super Duty Woody™

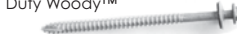

If you would like to see our catalog scan this QR Code or visit our website!



allowance, the new law extends the inclusion of qualifying leasehold improvement property, qualified restaurant property and qualified retail improvement property that was placed in service in 2014 into the 15-year MACRS class for depreciation purposes—that is, it can be depreciated over 15 years under MACRS.

**WORK OPPORTUNITY TAX CREDIT:** Under the tax extend-er bill, a building business can again apply for the Work Opportunity Tax Credit if they hire military veterans and active reservists. An even larger credit is available to small businesses that hire individuals who receive supplemental security income or long-term family assistance, were long-unemployed or service-disabled veterans. Other hiring-related provisions that were restored for the 2014 tax year include credits for businesses that hire qualified ex-felons, or qualified summer youth employees.

**SMALL BUSINESS FINANCING:** The 100 percent exclusion from capital gain allowed on the sale or exchange of qualified small business stock held for more than five years by non-corporate investors has been extended. Stock acquired by investors in a building business after 2014 will be entitled to only the regular 50 percent exclusion if not changed by our lawmakers.

**RECOGNIZING S CORPORATION BUILT-IN GAINS:** A corporate-level tax at the highest marginal rate (currently 35 percent) is imposed on an S corporation's net recognized "built-in gain." That built-in gain is usually gain that arose prior to the building operation's conversion from a regular C corporation to an S corporation, and arises when assets are sold. Under the new law, an S corporation's recognition period for built-in gains tax is five years rather than 10 years.

**ENERGY-RELATED TAX SAVINGS:** The extension of the energy efficient commercial buildings deduction allows an above-the-line deduction for energy efficient commercial buildings. In 2013, business owners who built or renovated property featuring renewable energy technology, such as solar panels or "green" lighting equipment could take advantage of a special tax deduction. Until this bill became law, the deduction could only be claimed on property placed in service before the end of 2013. Now, any such property opened in 2014 would qualify for the deduction as well.

There are, of course, far narrower provisions including tax breaks for film and theater producers, NASCAR racetrack owners, racehorse owners, and rum producers in Puerto Rico and the Virgin Islands included in the Tax Increase Prevention Act.

Since these extenders are for the 2014 tax year only, and coming late in 2014 left little time for planning, it may require changes to already-filed 2014 tax returns. Fortunately, once a building business's tax returns have been filed, changes can be made on an amended tax return.

Generally, a building business—or its owner—can change their mind about previously-filed tax returns within three years from the time the return was filed, or within two years from the time the tax was fully paid, whichever is later.

Individuals, sole proprietors, etc., use Form 1040X, Amended Individual Tax Return. A corporation that filed Form 1120 uses Form 1120X, Amended U.S. Corporation Income Tax Return, to file an amended return, while S corporations and partnerships

check a box on the Form 1120S or Form 1065.

Today, a builder or contractor can delay filing their 2014 tax return with little worry about the IRS's strict pre-payment rules. Using Form 4868, "Automatic Extension of Time to File a U.S. Individual Tax Return," a builder or contractor can obtain an automatic, six-month extension of time in which to file tax returns.

Incorporated building businesses may obtain the automatic six-month extension of time to file income tax returns by submitting Form 7004, "Application for Automatic 6-Month Extension of Time to File Certain Business, Income Tax, Information, and other Returns." Form 7004, is also used to obtain a six-month extension for filing some excise, income, information and other returns. The automatic six-month extension of time to file also applies to the returns of passthrough entities such as partnerships, S corporations and limited liability companies (LLCs).

The Tax Increase Prevention Act of 2014 is all about reducing a building operation's tax bill with incentives. So for 2014, 50 percent bonus depreciation is back and the dollar limits for Sec. 179 expensing are way back up at \$500,000, with a \$2.5 million investment ceiling.

Will your building business reap the reward of a lower tax bill thanks to the Tax Increase Prevention Act of 2014? **RB**

**Precoat Metals**

SNCE

INNOVATION  
FLEXIBILITY  
COVERAGE  
RESULTS

New ideas and  
innovative solutions  
for over 50 years.

NFBA  
FRAME  
BUILDING  
**EXPO**  
BOOTH #516

314.436.7010 **Precoat Metals**

1310 Papin Street St. Louis, MO 63103 www.PrecoatMetals.com

Circle Reader Service #399

## people in the news

BY RURAL BUILDER STAFF



CHRIS RAY

**LEVI'S BUILDING COMPONENTS HAS HIRED CHRIS RAY AS NATIONAL SALES MANAGER.** As a new addition to the Levi's Building Components team, Ray brings over 30 years of leadership experience gained from working in a variety of industries and the public sector.



JONATHAN WILLIAMS

**FABRAL HAS APPOINTED JONATHAN WILLIAMS AS PLANT MANAGER AT ITS LANCASTER, PENNSYLVANIA FACILITY.** Williams has more than 30 years of manufacturing experience, and 15 years of operational and sales experience in the building materials industry. Most recently he served as operations manager at Clyde, New York-based Weatheredge Building Products. Previously he spent nearly 20 years at Potlatch Corporation where he held progressively demanding positions ranging from packaging specialist to materials manager.



AARON WOODS

**THE BRADBURY CO. INC. ANNOUNCES SEVERAL PROMOTIONS.** Aaron Woods has accepted the position of field completion coordinator within the customer service department. Woods has worked in hydraulic assembly, and most recently as a test technician specializing in Bradbury eDrive Levelers. He will be responsible for coordinating equipment installations and startups through their completion.



MIKE NUZUM

Mike Nuzum is the new field service technician for the customer service department. After serving the company in electrical assembly, Nuzum is now responsible for assisting customers and Bradbury field technicians in troubleshooting equipment.



SHAWN FIELDS

Shawn Fields has accepted the position of parts and sales technician within the customer service department. Fields has served the company as a lathe operator for several years. He will be responsible for assisting customers and field technicians in placing parts orders, upgrades, and repairs.



ALAN JOHNSON

**VARCO PRUDEN BUILDINGS NAMED ALAN JOHNSON DISTRICT MANAGER.** His territory includes the majority of the Colorado market as well as part of Kansas, Nebraska, New Mexico, South Dakota and Wyoming. He is based in Colorado.



DAN STEPHENS

Also at VP, Dan Stephens was made district manager for the western region. His territory includes northern California, southern Oregon, northwestern Nevada and Hawaii. Stephens is replacing Joe Readd, who has taken on a new role as sales service representative for the western region.

## [more] industry news

### WDMA Releases 2015 National Policy Agenda for the Window, Door and Skylight Industry

The Window & Door Manufacturers Association (WDMA) has released a comprehensive advocacy agenda for 2015.

The priorities for the window, door, and skylight industry are aimed to aid in the recovery of the housing and construction industry, and support continued job creation.

The 2015 WDMA National Policy Agenda is divided into eight different policy areas: energy conservation, building codes, environmental stewardship, building safety, housing and economic policy, tax policy, product supply and trade and workforce/workplace.

The 2015 WDMA National Policy Agenda will be distributed to all members of U.S. Congress and key administration officials and will be used during WDMA members' visits with their elected representatives. **RB**



Designed for



# MAZE NAILS Stocks Painted Nails!

### Custom Prefinish Program Color

Prefinished Color	Maze Color #
LP Almond	M-058
LP Blue	M-256
LP Country Red	M-026
LP Cream	M-245
LP Harbor Grey	M-294
LP Khaki	M-251
LP Mist Grey	M-313
LP Sage	M-196
LP Sand	M-158
LP Walnut	M-040
LP Wheat	M-034
LP White	M-061



Color Matched Nails save BIG \$\$\$ in time and labor on prestained and prefinished jobs!



★ 20 Degree Stick  
Full Round Head Nails  
Available in Smooth & Ring Shank



★ Painted Coil  
Painted Coil Nails Available  
in Smooth & Ring Shank



★ 15 Degree Coil  
Roofing Nails for  
Blind Nailing LP Smartside



Each 5-lb. box includes 2 hammercaps to be used when driving painted nails (to reduce paint chipping)!

- Available in double hot dip galvanized coils, collated sticks and hand drive
- Available in pre-finished colors to match SmartSide® Trim & Siding
- Engineered for both face and blind nailing applications

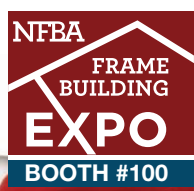

1.800.435.5949 • mazenails.com

Division of W.H. Maze Company  
Helping to build America since 1848



# Are You on the Fence?



**We** know where the safe side of the fence is. Everlast Roofing has learned that south Florida outdoor exposure testing has been the only acceptable manner to evaluate the long term performance of exterior finishes used in the North American construction market.

If your supplier tries to sell you something different; then you may be getting a paint finish that will result in an unhappy customer with a faded roof. Outdoor testing in other global regions, laboratory accelerated weathering tests, or no tests at all is risky business.

Get off the fence. Take the risk out of your business and come to Everlast Roofing!

**Toll Free: 888.339.0059**  
**[www.everlastroofing.com](http://www.everlastroofing.com)**

