

July 2015 • \$4.50

Rural Builder®

The Business Management Magazine for Rural Contractors

www.ruralbuilder.com

+PLUS:
The emerging
CLT market
p. 83

TOP TIPS:

**WINDOW
SELECTION &
INSTALLATION**

Building a Crew

**Finding & keeping
good help among
Millennials** P. 6



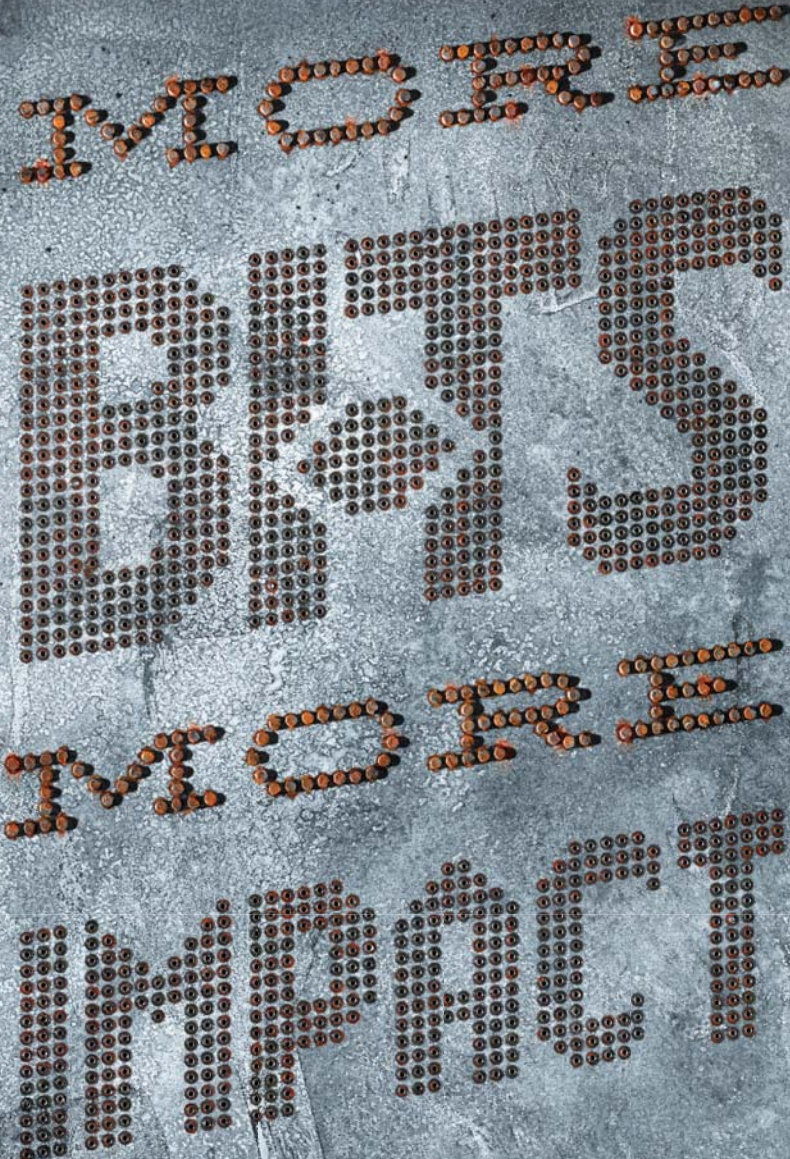

TAPCON® INSTALLATION SYSTEM



EXTENSIONS



METAL AND MASONRY BITS



DOUBLE-ENDED BITS



DOUBLE-ENDED COMBINATION BITS



NUTSETTERS



ADAPTERS FOR ALL DRIVERS

DEEP WELL BOLT-GRIP® 1/2"



EASILY EXTRACTS STRIPPED SCREWS AND BOLTS

DESIGNED FOR IMPACT, THE NEW IRWIN IMPACT PERFORMANCE SERIES™ BITS LET YOU DO MORE WITH YOUR DRIVER THAN EVER BEFORE.

With double-ended bits, Tapcon® installation system, extraction accessories, and the broadest range of tips and lengths, the Impact Performance Series is the most versatile on the market and has what it takes to get any job done. We even used it to make this ad.

www.irwin.com



Rural Builder

Volume 49 • Number 4

Group Publisher

Jamie Wilkinson

Publisher

David Davel

Editorial Director

Debbie Bradley

Editor

Sharon Thatcher - sharon.thatcher@fwcommunity.com
715-445-2214, ext. 13644

VP, Advertising Sales

David Davel

Advertising Sales

Gary Reichert - gary.reichert@fwcommunity.com
715-445-2214, ext. 13381

Publication Design

Nicole MacMartin

Production Coordinators

Kathy Budsberg - kathy.budsberg@fwcommunity.com
715-445-2214, ext. 13309

Patti Kirchner - patti.kirchner@fwcommunity.com
715-445-2214, ext. 13319

Subscription Services

386-246-3452

Office Phone

715-445-2214

Office Fax

715-445-4087

F+W, A CONTENT + ECOMMERCE COMPANY

Chairman & CEO

David Nussbaum

CFO & COO

Jim Ogle

President

Sara Domville

CDO

Chad Phelps

VP, eCommerce

Lucas Hilbert

SVP, Mfg. & Production

Phil Graham

VP, Communications

Stacie Berger

SUBSCRIPTION SERVICE

Subscription inquiries, orders and address changes can be made at constructionmagnet.com (click on "Subscribe"). Or by mail: Rural Builder, P.O. Box 421751, Palm Coast, FL 32142-1751. Or call (866)805-1574, International (386)246-3452.

Rural Builder (ISSN: 0898-3025) Volume 49 Number 4 is published monthly, except January, April, June and November, by Krause Publications, a division of F+W Media, Inc., 700 E. State Street, Iola, WI 54990-0001. Periodical postage paid at Iola, Wis., and at additional mailing offices. Canadian Agreement Number: 40665675. POSTMASTER: send address changes to Rural Builder, Circulation Department, PO Box 420235, Palm Coast, FL 32142. Copyright 2015 by F+W. Rural Builder and its logo are registered trademarks. Other names and logos referred to or displayed in editorial or advertising content may be trademarked or copyright. Rural Builder assumes no responsibility for unsolicited materials sent to it. Publisher and advertisers are not liable for typographical errors that may appear in prices or descriptions in advertisements. Mailed free to rural contractors and their suppliers throughout North America. Others may subscribe: \$29.98 for 1 year, \$55.98 for 2 years, and \$79.98 for 3 years in the U.S.; \$39.98 for 1 year, \$74.98 for 2 years in Canada.



fw



83

FEATURES [JULY 2015]

- 06 IN FOCUS** Building a crew
Tips to finding and keeping good help among today's Millennials
- 11 2015 GOLD KEY WINNERS**
Our annual showcase of companies that received top votes for the Rural Builder Gold Key of Excellence
- 83 ON THE FRONT LINES OF THE EMERGING CLT MARKET**
U.S. timber supplier positions for a future in cross-laminated timber
- 86 TOP TIPS** Window selection & installation
How to select and install the right options for the right job

DEPARTMENTS

- Editor's Note..... 4
- Industry News..... 10
- Advertiser Index..... 74
- New Products..... 74
- Product Profile..... 80
- People..... 88
- Classifieds..... 89
- Supplier News..... 90

AUGUST PREVIEW

7th annual Rural Builder Source Book

- Featuring special metal and post-frame projects
- Product profiles for all things metal and post-frame

[ON THE COVER]

It doesn't happen often these days: Roy Powell has been with the same company for 43 years. What does it take to keep employees like this? Related article on page 6.

Cover design by Nicole MacMartin.



80



E-MAIL THE EDITOR AT
sharon.thatcher@fwmedia.com

Check our website at
www.ruralbuilder.com

editor's note

BY SHARON THATCHER

Under cover: Gold Keys, CLT and windows

AS YOU WILL SEE AS YOU LOOK BEYOND THE COVER, THIS IS OUR ANNUAL GOLD KEY ISSUE. It is typically national and large regional companies that receive the most votes and take home the awards, but I'm always intrigued by the smaller companies that are nominated by equally loyal customers. This year, there were quite a few and even at the risk of overlooking someone, I'd like to acknowledge them here: Ford Wholesale (CA), Heartmark Cabinets (CA), Rindler Truss (OH), Contractors Building Supply (OH), North Coast Commercial Roofing Systems (WV), McClure & Johnson (WV), Barrasso & Sons (NY), Croft Lumber Co. (PA), Hep's Material Supply (PA), EPSCO (PA), Graber Roofing & Construction (KY), L&L Sales and Service (WI), Weekes

Forest Products (MN), and Rk Miles Lumber & Building Materials (VT). Kudos for being nominated.

A number of this year's Gold Key recipients have announced expansions or new products. It's an encouraging sign after so much economic uncertainty. Take a look and consider them when you need products for your next job.

Something else that intrigues me is cross-laminated timber construction. There is a small movement growing larger of CLT devotees here in the U.S., and it's people like Reinhard Sauter in Tennessee who are the pioneers. It has been popular for more than 20 years in Europe and Sauter is convinced it has a future here. He is betting big on that belief with a new award-winning CLT building and a pricey new machine that it houses. Read his story

in this issue. There are several photos included, but check online at ruralbuilder.com for additional photos showing the project from start to finish.

A note as well to check out engineer Al Geisthardt's article on window selection and installation. Geisthardt is a 2014 *Rural Builder* Hall of Fame recipient and he'll be delivering a workshop on installation of windows in steel clad buildings at the Frame Building Expo in 2016. Get a jump ahead in this issue, then sign up to hear more. Go to NFBA.org. **RB**



Sharon Thatcher,
editor
sharon.thatcher@fwmedia.com
800-726-9966, ext. 13644



ECO-FRIENDLY PRODUCTS

Manufacturer of Over 100 Environmentally Safe Insulating Ceramic Waterproofing Paints and Coatings



www.nationwidecoatings.com

RESIDENTIAL - COMMERCIAL - INDUSTRIAL

| INTERIOR CERAMIC PAINTS | EXTERIOR CERAMIC PAINTS | ELASTOMERIC WALL COATINGS | PROTECTIVE WOOD & DECK FINISH | CLEAR ACRYLIC ROOF COATINGS | ELASTOMERIC ROOF COATINGS |
|--|---|---|---|--|---|
|  |  |  |  |  |  |

ELASTOMERIC WATERPROOFING INSULATING CERAMIC ROOF COATINGS - ZERO V.O.C. INSULATING CERAMIC INTERIOR & EXTERIOR PAINTS
ELASTOMERIC CERAMIC WALL, TEXTURE & INDUSTRIAL COATINGS - CONCRETE & DECK PAINTS, STAINS, CLEAR COATS & SEALERS
WOOD STAINS, CLEARS & DECK-OVER COATINGS - EPOXIES - COLOR MATCHING & CUSTOM FORMULATIONS

CALL TODAY FOR FREE SALES & MARKETING BOOK!

NATIONWIDE PROTECTIVE COATING MANUFACTURERS, INC.
SARASOTA - FLORIDA - USA



The PERManent Coating Solution™
1.800.423.7264  941.753.7500

Circle Reader Service #463

More profitable ways to tell snow where to go



Easy-Install AceClamp® Snow Rail

**No-Scratch solution
for medium to heavy snow loads**

If you work where winters are hard, AceClamp® Snow Rails provide superior loading forces and make metal roof snow protection easy. Quick to install, they come in one-, two- or three-rail systems that reduce the hazards of ice and snow slides. Brackets and clamps are pre-assembled, will not scratch the SSMR and don't require setscrews. Choose the patented AceClamp® ML (FM Approved) for top loading, or the AceClamp® A2® for side loading. (UL Listed).

Precision Snow-Guards™

**Looks good, works great
for light to medium snow loads**

Precision Snow-Guards™ are molded from UV-stabilized polycarbonate for long life, and adhere securely to metal roofs in no time. Standard colors match common roof-color choices and custom colors are available. Choose the King or the Queen design, depending on your structure's needs. They can also be pre-drilled for screw mounting. Either way, you put snow in its place.

PMC Industries Inc

Cash in on more snow protection jobs. Call AceClamp® direct today at (860) 351-0686, or visit www.aceclamp.com
You'll buy direct from the manufacturer for a lower total installed cost and a higher degree of total confidence.

The PROOF Is On The ROOF™



Building a crew

Tips to finding and keeping good help among today's Millennials

IN THE FIELD OF MANAGEMENT SCIENCE, the concept of “organizational socialization” describes how employees progress through three phases—anticipation, encounter, and metamorphosis—as they transition from newcomers to valued veterans.

“My responsibilities cover all three phases,” relates Jimmy Terry, crew developer and trainer for FBi Buildings, a post-frame contractor in Remington, Indiana. “I’m involved in recruiting and getting out the message that our company is a desirable place to work. Then I handle new employee orientation and, after that, conduct ongoing training so that our crew members can grow and achieve their potential.”

At FMI Corporation of Raleigh, North Carolina, a management consulting firm for the construction and engineering industries, senior consultant Bryan Kucinski has helped clients work through each phase. “It begins by articulating your company ‘brand’ and why you’re a great place to work,” he explains. “Then once people come aboard, training doesn’t stop with passing along information during orientation. Nor does it stop with teaching job skills. The goal is behavior change so that the employee becomes engaged with your company and its culture.”

Successfully navigating the phases of employee socialization, Terry and Kucinski agree, is a demographic necessity. “The Baby Boom generation will mostly retire in the next decade,” reports Terry, “and Generation X will be right behind. After that, we’re down to the Millennial Generation—and they’re not attracted to working in a trade such as construction. So if we don’t recruit and develop our share of young people now, our industry’s future will be in doubt.”

Rural builders may be tempted, Terry adds, “to think that, since the economy is down and lots of people are looking for construction jobs, then why put effort into employee development? Can’t crews be easily replaced? But construction isn’t just a product, it’s also a service. Your crews are constantly interacting with customers. It pays to develop the people who represent you. They’re your biggest assets.”

Kucinski concurs that “the current situation of three generations working together—Baby Boomers, Generation X, and Millennials—won’t last forever. Millennials are the future of our industry. But having grown up with the Internet, they expect things to happen at the speed of light. So if they don’t see a path in your company to growth and promotion, they’ll be gone.”

► Phase 1: Anticipation

Employee development starts long before newcomers are put on the payroll. “The process actually begins by hiring the right people—that is, the people who are a right fit for the culture



Crew members with a long and established history with a company are an increasingly rare and valued resource. Found on one Wick Buildings job site in Merrill, Wisconsin recently were these veterans (left to right) John Boda with 46 years, and brothers Loren Powell with 39 years and Roy Powell with 43 years.

of your organization and who are therefore promotable,” states Kucinski. “Yet even that presupposes you know what your culture is and what you want it to be.”

Construction contractors have traditionally defaulted to a “let’s get it done” culture. “But if you want to recruit and retain good employees, especially Millennials, then the days of ‘just grab a set of plans and build it’ must end,” continues Kucinski. “For one, the trend in delivering construction projects is moving toward design/build and other methods where the various parties cooperate. So you can’t afford a ‘Lone Ranger’ culture. You want a team environment. Then for another, Millennials are more attracted to a team culture where they can have input.”

Because rural builders tend to be smaller organizations, notes Kucinski, “Relationships are more linear and direct, rather than hierarchical. And having a ‘flat hierarchy’ actually gives you an opportunity to cultivate a ‘family’ atmosphere with a sense of purpose, integrity, and fairness that can be attractive to many employees and induce them to stay long-term.”

The management literature on organizational culture is vast. *Corporate Cultures*, one of the first books published on the subject, held that “strong organizations” have values appropriate to their business environment, heroes who exemplify those values, rituals that celebrate those values, and a network of people who communicate those values. Another classic, *In Search of Excellence*, argued that “excellent organizations” cultivate a respectful and positive atmosphere, avoid too much

complexity in structure and staffing, allow employees to voice new ideas and take risks, and promote unity of purpose while encouraging diversity for innovation.

Company leaders foster such a culture through six common-sense mechanisms: what they focus on, how they respond to critical events, how they allocate resources, what behaviors they consciously or unconsciously model, what they reward and punish, and who they hire and promote. Ideally, a company's stated values and its "unwritten rules" align so that managers and workers behave in ways that reflect the desired values.

These dynamics are evident at FBi Buildings where Terry's recruitment efforts are boosted by his company's commitment to a positive culture. "Hiring the kind of employees who can be developed into great team members," he says, starts at the anticipatory phase when "potential recruits say to themselves, 'That would be a good place to work.'"

Terry makes recruitment visits to colleges and universities throughout the Midwest. His message is simple but effective: "We want to hire good people and hang onto them. So we make a promise. We're not just offering you a job, but a career. Our goal is to empower you. That commitment starts at the top and goes across the organization. It says a lot when I take along an employee who's an alumnus of that college and he tells potential recruits about our culture."

► Phase 2: Encounter

New hires likewise encounter FBi Buildings' commitment to empowering employees when they attend orientation. This summer the company is opening a 1,600 square-foot training center and launching a new way to help newcomers learn the ropes.

"When people feel good about their jobs, they do better—and that starts when they come on board," explains Terry. "Builders traditionally train new employees by sending them out with existing crews. But put yourself in the new person's shoes. The crew is already performing well and so you feel like a fifth wheel. It's intimidating."

Instead, new employees at FBi Buildings will first be spending time in the training center, working on actual buildings in a controlled and supervised environment. "It's going to build their confidence," Terry believes, "so that, when they do start going out with a real crew, they'll feel good about themselves and do a better job."

One impetus for the new approach is something Terry learned from exit interviews with departing employees. "Most new hires who last beyond the first few weeks end up staying with us long-term," he reports. "Thus, most of our turnover happens within those early weeks. And while our turnover rate is below industry averages, we found that about 15 percent of the people who left us felt we hadn't given them enough training."

Too often, orientation of new employees emphasizes what Kucinski calls only the first two levels of training. At the first and most basic level, training programs impart information about company policies and procedures. Then at the second level, job skills are taught. "And that's where many training

**YOU NEVER STOP IMPROVING
HOW YOU OPERATE...
NEITHER DOES RITCHIE.**



It's what's on the inside that defines us.
You know it, and we know it.
Because we share the same values.
Ingenuity, commitment, sense of pride...

These are the values that built this country;
They are the values that built this company.

*Ritchie, proud to be a partner
to the American Cattleman since 1921*

www.ritchiefount.com

Proud Sponsor of



Ritchie
Fresh Water
For Life™

BY MARK WARD, SR.

programs stop,” he cautions. “Since skills are actionable and results are measurable then, as they say, ‘What gets measured gets done.’”

But Kucinski advises that the third level of training is just as important. “It’s what I call the ‘adhesion’ level where

new behaviors are grafted on to employees,” he relates. “Leadership development is an obvious example of training that inculcates new behaviors. But with *all* your workforce—from orientation onward—you want people who are *engaged*. Employees who have a sense of

purpose and feel a part of something bigger than themselves are integral to your sustainability and profitability.”

Thus, Terry and Kucinski agree that managers involved in the training of both new and experienced employees must think on two levels: What is the best way to impart information? And what is the best way to change behaviors so that employees reach the “metamorphosis” phase to become fully functioning and valued members of the team?

► **Phase 3: Metamorphosis**

Corporate trainers the world over debate the best methods for teaching and employee learning. Kucinski believes the answer to that question begins with the employee rather than the trainer. “Each employee is different in personality and learning style,” he counsels. Employers might consider having employees take a self-assessment questionnaire such as the well-known Myers-Briggs Type Indicator. “You can increase the effectiveness of your training,” he adds, “if you know what motivates a person—achievement, advancement, recognition, responsibility?”

Terry concurs that an effective trainer “is a good listener who learns about each employee and his or her learning style, and then fits the training to that style—whether it’s using a lecture with PowerPoint, or a hands-on exercise, or time with a computer simulator.”

Nevertheless, Terry believes that trainers can be guided by certain universals. “Spend time on the ‘why’ question,” he advises. “If employees understand why a given policy or procedure is expected, then the rest will follow.”

Further, while critiques from supervisors and peers are valuable, allowing employees to critique themselves is a uniquely powerful training tool. FBI Buildings installs video cameras not only at its training center but also on job sites—not to spy on crew members, but so they review their own performance. “I call it Operation Game Film,” says Terry. “Like a football coach, I put together ‘game films’ for our trainees and crews to watch and learn from.”

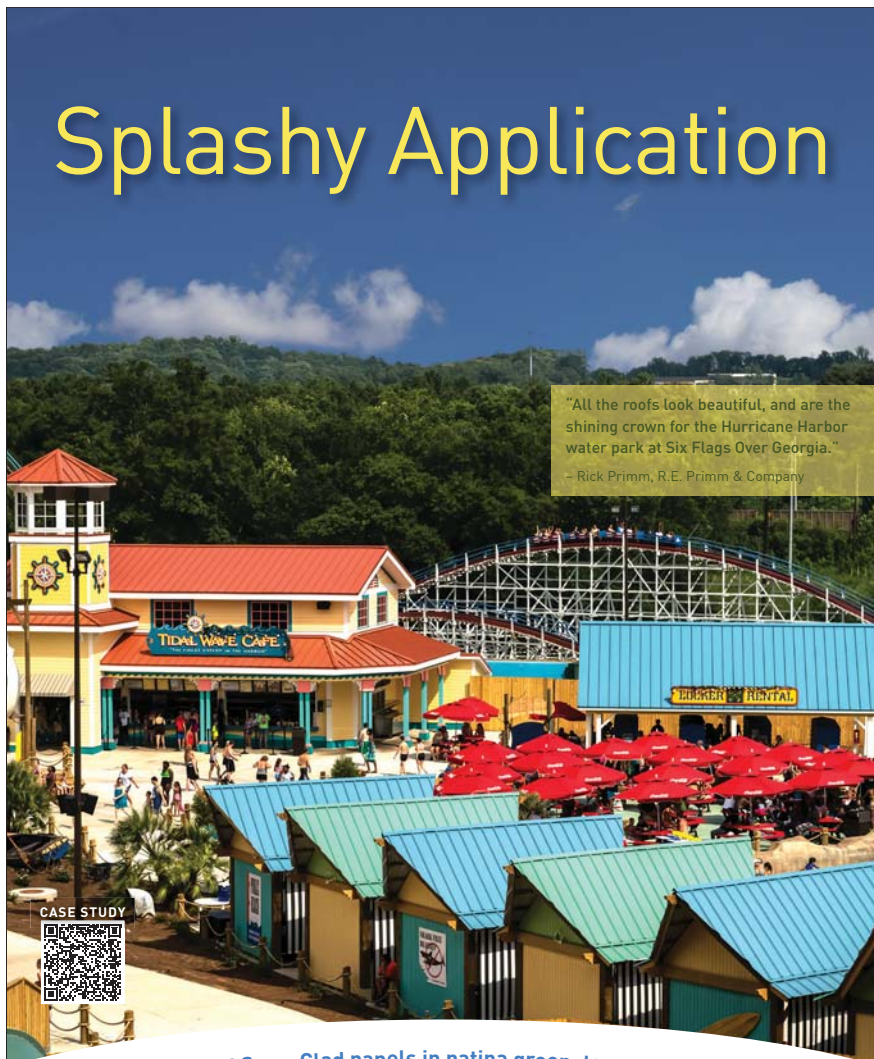

“All the roofs look beautiful, and are the shining crown for the Hurricane Harbor water park at Six Flags Over Georgia.”
— Rick Primm, R.E. Primm & Company



PAC-CLAD M-36 and Snap-Clad panels in patina green, terra cotta and military blue

Six Flags Over Georgia’s new Hurricane Harbor water park near Atlanta features 22 buildings covered with Petersen PAC-CLAD .032 aluminum standing seam and exposed fastener roofing panels.

Multiple roof colors were selected to complement the park’s island theme, making for a bright and stimulating environment. Most of the PAC-CLAD 38 colors meet LEED, ENERGY STAR, and cool roof certification.



WWW.PAC-CLAD.COM | IL: 1 800 PAC CLAD | MD: 1 800 344 1400 | TX: 1 800 441 8661 | GA: 1 800 272 4482 | MN: 1 877 571 2025

Circle Reader Service #485

As for the best ways to change behaviors and foster engaged employees, here too advice is varied. “One key, however, is high ‘emotional intelligence’ or the ability of a leader—and a trainer must be a leader—to perceive and respond to emotion,” says Kucinski. “Another key is knowing the difference between a ‘manager’ and a ‘leader.’ A manager only *transacts* work with employees: ‘If you do this, I’ll do that.’ But a leader strives to *transform* employees.”

Management science has long moved past the idea that some people are “born leaders.” Instead, organizations are advised to understand how certain “leadership styles” correlate to certain “followership styles.” Leaders must learn to adjust their leadership style to the skill level and motivation of employees. Sometimes task-related guidance is needed most, while at other times a relational approach is more productive.

One leading model categorizes followership styles along two dimensions: engagement (active or passive) and thinking (independent/critical or dependent/uncritical). Employees are classed as either *passive* (passive engagement and uncritical thinking), *conformist* (active and uncritical), *alienated* (passive and critical), or *exemplary* (active and critical). Fostering the latter, in order to cultivate employees who are actively engaged and who think independently and critically, should be the goal of every organization.

“An aspect of empowering your employees is, in a sense, that they *all* become leaders, even if only at the level of self-leadership,” states Terry. Toward that end, he continues, “I find that my biggest challenge as crew developer is to get new hires through their first year. That starts with me being transparent and establishing a bond of trust with new employees. Then after that first year, once you’ve built that bond, employees can start reaching toward their potential.”

FBi Buildings creates ways, both large and small, for employees to metamorphose into valued team members. “Our culture—which starts with a commitment from the top—is for employees to take ownership of what they do,” Terry reports. “We seek ways for them to feel included by giving them input on policies and procedures that directly affect them.”

The company has a variety of steering committees and regularly staffs them with crew people who have low seniority, as well as managers. A recent example is a committee on fall protection that included executives, managers, and laborers in equal proportions.

Moreover, FBi Buildings has created a culture in which “people know that if they’re promotable, we *will* promote them—even if we sometimes have to make ‘room’ for them somewhere. But that’s better than losing them,” attests Terry.

One of Terry’s initiatives is an annual leadership development course to which he invites half a dozen young crew members. “They’re invited because they’ve shown the skills, aptitude, or desire to take the next step in their careers with us,” he explains. “We ask them what training they need to advance—whether it’s how to supervise people, how to use an iPad, or how to build a horse barn. Sometimes what they need are the ‘soft’ people skills, but other times it’s technical skills. So we put them in situations



The Baby Boom generation will mostly retire in the next decade and Generation X will be right behind. After that, we’re down to the Millennial Generation—and they’re not attracted to working in a trade such as construction. So if we don’t recruit and develop our share of young people now, our industry’s future will be in doubt.”

to practice what they feel they need to learn.”

These employees, believes Terry, exemplify the ideal of team members who have “reached the point of saying, ‘I want to be with this company long-term. I’m all in!’”

Whether employees attend leadership training or not, however, development is ongoing. FBi Buildings conducts an annual employee review process. For new employees, the process can lead to quarterly wage increases for the first 15 months of employment. And while increases for managers are considered once a year, says Terry, “non-management employees don’t always have to wait that long.”

The company strives to conduct annual reviews in a way that is individualized and yet conforms to fair standards for all. “We use a ‘competency log’ to build metrics on each crew member—their productivity, their safety record, the quality of their work as indicated by the number of customer callbacks,” explains Terry. “So while the review is conducted fairly via metrics, we can also customize a development plan for each employee.”

Such an approach illustrates, says Kucinski, a bottom-line principle of employee training and development. “It has to be an ongoing process,” he counsels, “and not just, ‘Go attend a two-day seminar’ or ‘Here’s a video to watch.’ The resources are out there for even a small builder to have a great training program—whether it’s computer-based training, resources from your industry association, or onsite training from companies like ours. The point is that employee development must be continuous, which means your commitment must also be continuous.” **RB**

Mark Ward Sr., a frequent contributor to Rural Builder, is an assistant professor in organizational and business communication at the University of Houston-Victoria.

MCA study shows U.S. metal industry grew 4% annually in good times & bad

THE MARKET FOR METAL PRODUCTS IN THE U.S. GREW 4 PERCENT ANNUALLY OVER THE PAST FIVE YEARS, ACCORDING TO AN INDUSTRY STUDY RELEASED BY THE METAL CONSTRUCTION ASSOCIATION (MCA). This growth is significant because it occurred from 2009 through 2014, during the economic downturn when construction volumes declined and building owners and specifiers were particularly cost conscious.

According to a press release issued by the MCA, the study shows that the market for metal roofing was even greater. Growth was seen in both the residential and commercial sectors. In the residential

market, use of metal roofing grew 7.1 percent in new construction and 4.1 percent in replacement roofing. In the commercial sector, metal roofing grew 9.7 percent in the five-year period. The industry also saw an 8.7 percent growth in metal wall panels in commercial building during this same time period.

“We are encouraged by this data because as the economy continues to improve and construction volumes further recover, we see even greater opportunities for growth in metal building materials,” said John Ryan, MCA’s director of marketing.

MCA credits much of the growth to the metal industry’s efforts to educate the design community about the long-

term value of metal roof and wall products. Key benefits of metal products over competitive materials that are promoted by MCA members include: energy efficiency and performance, LEED certification/green building, aesthetic appeal, life cycle cost, durability, and speed of construction.

MCA joined together with five partner associations beginning in 2009 to compile the data for this industry study. Study participants included data from the key associations: The American Iron & Steel Institute (AISI), the Aluminum Association (AA), Metal Roofing Alliance, National Frame Builders Association (NFBA) and the National Coil Coaters Association (NCCA). **RB**

“Still Making a **WORLD OF DIFFERENCE**”

EZ TITE FASTENER

PLY-FAST SEALER

PLY-LO FASTENER

METAL FAST SEALER

PLY-LO LOW PROFILE FASTENER

- Colors to match any Rollformed Steel
- Hundreds of Closure Styles & Angle Cuts
- Dozens of Sales Professionals
- Factory Delivery Fleet & Fast Delivery
- High Quality Products for any Application

East Coast
FASTENERS & CLOSURES, INC.
A Plyco Company. Build Plyco Strong.

800.558.5895 • Fax: 800.257.5926 • www.plyco.com • Elkhart Lake, Wisconsin

Circle Reader Service #498

WINNERS OF THE GOLD KEY 2015 OF EXCELLENCE



IT IS TRULY AN HONOR for *Rural Builder* staff to acknowledge the following companies that have earned the *Rural Builder* Gold Key of Excellence for 2015. The magazine has sponsored this award for the past 33 years. The companies chosen are based on a lengthy balloting process that begins each winter at the Frame Building Expo and culminates with this issue.

An invitation for nominations and votes were solicited via e-mail, an online survey system, standard mail and fax.

More than 150 companies received votes this year; however, we have narrowed the field to the following 58 companies. Learn more about many of these companies as they share their histories and products in the following pages.

33 GOLD KEY AWARDS

CannonBall:HNP
Klauer Manufacturing Co.
McElroy Metal
Plyco Corporation

32 GOLD KEY AWARDS

Maze Nails

31 GOLD KEY AWARDS

Fabral
Sukup Manufacturing Co.
Wick Buildings

30 GOLD KEY AWARDS

American Building Components

29 GOLD KEY AWARDS

A.J. Manufacturing

27 GOLD KEY AWARDS

Dynamic Fastener

24 GOLD KEY AWARDS

RigidPly Rafters

21 GOLD KEY AWARDS

Energy Panel Structures
National Hardware

20 GOLD KEY AWARDS

Central States Manufacturing

14 GOLD KEY AWARDS

Leland Industries

13 GOLD KEY AWARDS

Everlast Roofing
Graber Post Buildings
MWI Components
Palram Americas

11 GOLD KEY AWARDS

Classic Equine Equipment
Swenson Shear

10 GOLD KEY AWARDS

Starwood Rafters

9 GOLD KEY AWARDS

ABC Supply Co. Inc.
Ideal Building Fasteners
North Star Metals
Sealtite Building Fasteners
Triangle Fastener Corp.

8 GOLD KEY AWARDS

Becker Specialty Corporation
MAC Metal
Western Products

6 GOLD KEY AWARDS

Levi's Building Components
Richland Laminated Columns LLC
Simpson Strong Tie
Valspar

5 GOLD KEY AWARDS

H&H Metal Products
Mill Steel
Perma-Column
Schweiss Doors
SnoBlox-Snojax

4 GOLD KEY AWARDS

The Bradbury Co. Inc.
Dura Coat Products Inc.
Fasteners Direct
Sno Gem Inc.
Steel Dynamics
Varco Pruden Buildings

3 GOLD KEY AWARDS

A.B. Martin Roofing Supply
DBCI
SNOBAR

2 GOLD KEY AWARDS

Burrow's Post-Frame Supply
Firestone Building Products
S-5!

FIRST YEAR GOLD KEY AWARDS

Direct Metals
EDCO Products
Hansen Pole Buildings
Metal Rollforming Systems
MFM Building Products
Novagard Solutions





ABC SUPPLY CO.

GOLD KEYS WON: 9

W: www.abcsupply.com



■ For more than 30 years, ABC Supply has delivered the high-quality products and expert service that make it easier for contractors to grow their businesses. As the largest wholesale distributor of roofing in the United States and one of the nation's largest distributors of siding, windows and other select exterior building products, ABC constantly finds new ways to better serve customers.

ABC Supply's commitment to contractors starts with a team of nearly 8,000 associates, all specially trained to tackle even the most challenging jobs with proven solutions. From material selection to order placement and delivery, associates consistently deliver accurate, seamless service from start to finish. This dedication was recently honored with ABC's ninth Gallup Great Workplace Award, which recognizes organizations with the most enthusiastic and committed work forces.

To complement the expert support provided in-store, ABC Supply recently introduced a new online program that provides access to ABC's products and

pricing 24/7. ABC Connect allows contractors to build material lists, create estimates and submit orders in real time, whether they're working from the office, at home or from a job site. Customers can keep their businesses moving when and where it is convenient for them—not just during normal business hours.

ABC Supply is focused on giving customers unique tools that help them save time and money. ABC's Freedom Programs provide value-added marketing services that allow contractors to get the word out about their businesses through targeted mail, websites, marketing starter kits, job site signs or in-home finance.

Solution Centers in ABC branches feature comprehensive product displays, making them an ideal place for contractors to review projects and samples with their customers. ABC Supply partners with industry-leading manufacturers to carry an assortment of roofing materials for low-slope and steep-slope applications. ABC also carries a wide variety of siding, windows, doors, gutters and rainware and decking and railing products. **RB**



www.abcsupply.com

Your Competitive Edge

At ABC Supply, you have a choice of top brands and products. You'll work with a trusted, knowledgeable distributor who understands your company's service needs and gives you a competitive edge in a forever-changing market.

Look to ABC Supply for:

- Uniform service practices of one company with over 450 locations
- Choice of top brands, products, tools and accessories
- Competitive pricing, electronic billing, product bundling, and custom reporting
- Order accuracy, delivery coordination and prompt communication

Experience the ABC Supply difference for yourself



Partnering in your success for over 30 years

Roofing | Siding | Windows | Gutter | Tools | Accessories

Circle Reader Service #310

ABC
Supply Co. inc.



THE BRADBURY CO. INC.

GOLD KEYS WON: 4

w: www.bradburygroup.com **p:** 620.345.6394



■ **Serving as the headquarters of The Bradbury Group of companies, Bradbury manufactures an extensive line of roll forming and coil processing equipment for the metal building and roofing industry.** Product lines include a variety of roll formers for panels, insulated products, purlins, metal trim, and portable roll formers for various metal roofing profiles.

TRIM MANUFACTURING EQUIPMENT

Bradbury's roster of trim shop equipment includes Long Folders, Panther Cub II Slitter/Shears, uncoilers and recoilers, stand-alone sheet slitters, hemmers, formed ridge cap and various panel notch presses for transition trims. Bradbury trim roll formers are supplied with tooling sets to produce one to four profiles depending on customer requirements. By utilizing combination tooling in a four-wide application, the capacity of the trim roll former can be increased to even more shapes.

METAL PANEL ROLL FORMING LINES

The Bradbury Group's complete solutions for panel roll forming lines include the high production Bradbury B.O.S.S.™ Series, the Challenger Series for mid-

level production requirements, and the Discovery Series, ideal for startup companies that wish to enter the market with high quality panel at an entry level budget. Configurations include pre-cut, post cut, Single High, Double High®, and Rafted® roll formers with flying or stop-to-cut shears.

CONCEALED FASTENER PANEL LINES

The Bradbury Group offers concealed fastener and standing seam roll forming lines that are capable of notching, punching, swaging, and in-line sealant application. Lines are available in plant or portable, on-the-fly shearing or feed-to-stop operations to meet all production requirements.

INTEGRATED BUSINESS SOLUTIONS

The Bradbury Group has solutions to integrate production equipment with your ERP or design software. Data transfer from each line in the plant to the office, and material optimization systems provide real-time information you need to evaluate manufacturing processes and make more informed business decisions.

TECHNICAL SERVICE

Our knowledgeable staff has many years of service in the metal process-



ing industry and is ready to assist you with your spare parts needs, service contracts, and technical questions. The Bradbury Group utilizes the latest technology in remote diagnostics, offers a 24 Hour/365 day service hotline, and maintains, group wide, over 90 engineers and 75 technicians to ensure our customers are supported in a timely fashion, minimizing down-time.

To see equipment photographs and find additional information about the companies of The Bradbury Group, their individual products, and integrated manufacturing systems, visit the website. Subscribe to The Bradbury Group news feed and be the first to know about new technology updates, used equipment and trade-ins, new equipment specials, and product announcements. **RB**



Year Founded
1959

320
 Employees



BRADBURY

THE BRADBURY CO., INC.

Portable Rollformers for Commercial and Residential Roofing

- Pre-cut or post-cut panel shearing
- Multiple decoiler options available
- Multiple panel widths
- In-line mastic applicators
- In-line panel notching option
- Beck Automation Cobalt® portable controller



Portable Roofing Rollformer with quick change over



Lead Trail Notching Presses



Produces in-plant-quality parts on site



Beck Cobalt® multi-batch controller

THE BRADBURY GROUP



Circle Reader Service #435

620.345.6394
www.bradburygroup.com



CANNONBALL:HNP

GOLD KEYS WON: 33

w: www.cnbhnp.com p: 800.766.2825



■ **CannonBall:HNP is a leading supplier of components for the post frame and metal building industries.** For nearly 100 years, builders have relied on CannonBall for versatile design, affordable pricing, personalized support and quality products.

DOOR TRACK SYSTEMS, SLIDING DOORS & ACCESSORIES

The original producer of round track and trolley sliding door systems, CannonBall offers the most complete line of round track products and accessories. Brands like industry-standard Keyhole™ track, easy install Quick Track™, heavy-duty Tubular track and many specialty lines allow for the widest possible variety of sliding door configurations. Kwik Frame™ and Bigg Frame™ complete door systems also take the guesswork out of building sliding doors from scratch, all the while providing superior quality at an affordable price.

“The sliding door and door track system market continues to grow in interesting directions,” said Jeff Rastocan, CannonBall’s General Manager. “Design elements that were once strictly agriculture-focused are finding new uses in commercial buildings and homes. As this interest grows, we want to ensure CannonBall offers the best assortment of product for both exterior and interior uses.”

ENTRY DOORS & ACCESSORIES

Designed with professional looks and field adaptability, CannonBall’s Entry Door offerings meet a wide range of builder needs. The new 1900-Series – CannonBall’s biggest product launch to date

– provides high aesthetics, steel construction and multi-use functionality in agriculture, commercial and metal building settings.

“This year’s 1900-Series launch was a double-win for us,” said Rastocan. “The door is meeting customer quality and flexibility needs, while growing us as a company and expanding our manufacturing platform. Expect more option availability as this line grows in popularity.”

Specialty doors are available through the 2000-Series, offering thermal breaks, fire rated models, increased durability and a full range of door accessories.

Price-conscious agriculture projects focus on the 1700-/1800-Series doors for fast installations, rolled and capped-edge looks and a variety of available panel skins.

BUILDING MATERIALS & CONSTRUCTION HARDWARE

CannonBall distributes building materials like Palram Sunsky® polycarbonate sheeting and Ag-Tuf® PVC wall liners – providing natural light in building projects, energy consumption savings and low maintenance, chemical-resistant wall panel options. Additional building materials and hard-

ware include rFoil™ reflective insulation, EMSEAL® closure tape, fasteners, door accessories, security hardware, hinges and much more.

“Case studies have shown that standard fiberglass reinforced plastic doesn’t provide the long-term illumination or energy savings of polycarb,” said Rastocan. “Pair quality product with our promotional programs, and you have a cost-saving solution for buyers and builders alike.”

Along with these key product lines, CannonBall also offers custom accessories like Dutch doors, cupolas, horse stall systems and accessories, roll-up doors, windows, ventilation systems and much more. **RB**



THANK YOU CANNONBALL CUSTOMERS

FOR OUR BIGGEST PRODUCT LAUNCH EVER!

NOW LET'S OPEN SOME DOORS TOGETHER...

CANNONBALL

**1900-SERIES
ENTRY DOORS**

**Open
FOR BUSINESS!**

As seen at:
NFBA
FRAME
BUILDING
EXPO
Louisville, KY

- Professional looks and field adaptability for any building project
- 24-gauge steel skin, 16-gauge steel jamb and Grade 40 security
- Wide variety of panel embossment options

Recommended Use

| | |
|-------------|-------------------------------------|
| Agriculture | <input checked="" type="checkbox"/> |
| Commercial | <input checked="" type="checkbox"/> |
| Metal | <input checked="" type="checkbox"/> |

Applications for all building markets:

Agriculture Commercial Metal

OUR NEWEST, MOST VERSATILE DOOR IS NOW AVAILABLE!

800-766-2825 • Beloit, WI
www.cnbhnp.com

CANNONBALL

Please provide this coupon and a cut-out 1920-model box label to the address listed below for redemption of rebate amount.

\$50 RETAIL REBATE*

Continental U.S. & Canada Only.
Program Dates: 07/01/15 – 08/31/15.
Redemption Expiration: 10/01/15.



1920 Steel Entry Door

- 24-gauge steel panel / 16-gauge steel jamb
- 3068 Call Size (40" x 81-5/16" out-to-out)
- White plain panel with universal swing (embossment options available)

**MAIL THIS COUPON & A CUT-OUT 1920 BOX LABEL
TO THE FOLLOWING ADDRESS FOR REBATE REMPTION:**

**CannonBall Retail Rebate
555 Lawton Ave. | Beloit, WI 53512**



2015

* = Not redeemable for cash or credit. Not valid as a discount on original 1920 Entry Door purchase. Rebate amount paid via Visa gift card. Limit one rebate per customer mailing address.

800-766-2825 • Beloit, WI
www.cnbhnp.com



Circle Reader Service #386



DURA COAT PRODUCTS INC.

GOLD KEYS WON: 4

W: www.duracoatproducts.com P: 951.341.6500



There's more to paint than pigments and resins...

6 things to know before making your next big paint decision

■ It takes a lot of confidence to assign a 30- or 40-year warranty to a product that never gets a break from Mother Nature. Here's why Dura Coat Products does it every day.

1. SOLVES PROBLEMS THAT OTHERS CAN'T

Dura Coat Products was founded 29 years ago by solving an environmental challenge that limited the number of hours a customer's factory could operate. That break-through—making it possible for full-time production to resume—was a factory-saving milestone. Finding solutions is indicative of Dura Coat's commitment to serving its customers.

2. BORN WITH A GREEN DNA

That first product, though a tough environmental challenge, was so proficient, it still meets today's even tougher requirements. Environmental responsibility is part of the company's DNA.

3. RAISED THE BAR ON RESINS

Resin is the heart of any coating so those off-the-shelf, one-resin-fits-all formulations just don't measure up at Dura Coat. With specialized labs dedicated to resin research and some of the industry's best resin experts, Dura Coat has developed new proprietary resin technologies that out-perform yesterday's old standbys.

4. MADE FOR EACH OTHER

A systems approach is mandatory in aircraft and space vehicles where failures are unacceptable. All components are designed to work in unison for top performance. Dura Coat feels the same way about its coatings. Resins, pigments, and additives used by Dura Coat are formulated to work perfectly together because they're designed for total performance. And they also work physically and efficiently for the coater, the roll former, the installer and the owner.

5. TEAM PLAYER

A good team player provides accurate color matching, repeatability, fast turn-around, field support and help developing new products. One customer said, "Dura Coat is willing to come to the table, willing to make paints, willing to run trials with us. We make their commitment part of our everyday thinking."

6. LASTING RESULTS

One of Dura Coat's key products is Ceramel. Its XT-40S coil finishes are formulated from a proprietary polymer resin to remain super hard and physically inert to resist long-term chalking, fading and weathering. Using the highest quality cool pigmentation assures color and gloss retention. Ceramel's weathering characteristics make it the cost-effective choice for commercial, monumental and residential applications, especially roof panels, tile and shingle applications. Ceramel withstands tough post-forming operations and runs on high speed lines. Fully warranted, it is available with Cool Roof Energy Star compliant colors. For a coating with confidence, contact Dura Coat Products at 951-341-6500 or 256-350-4300. **RB**



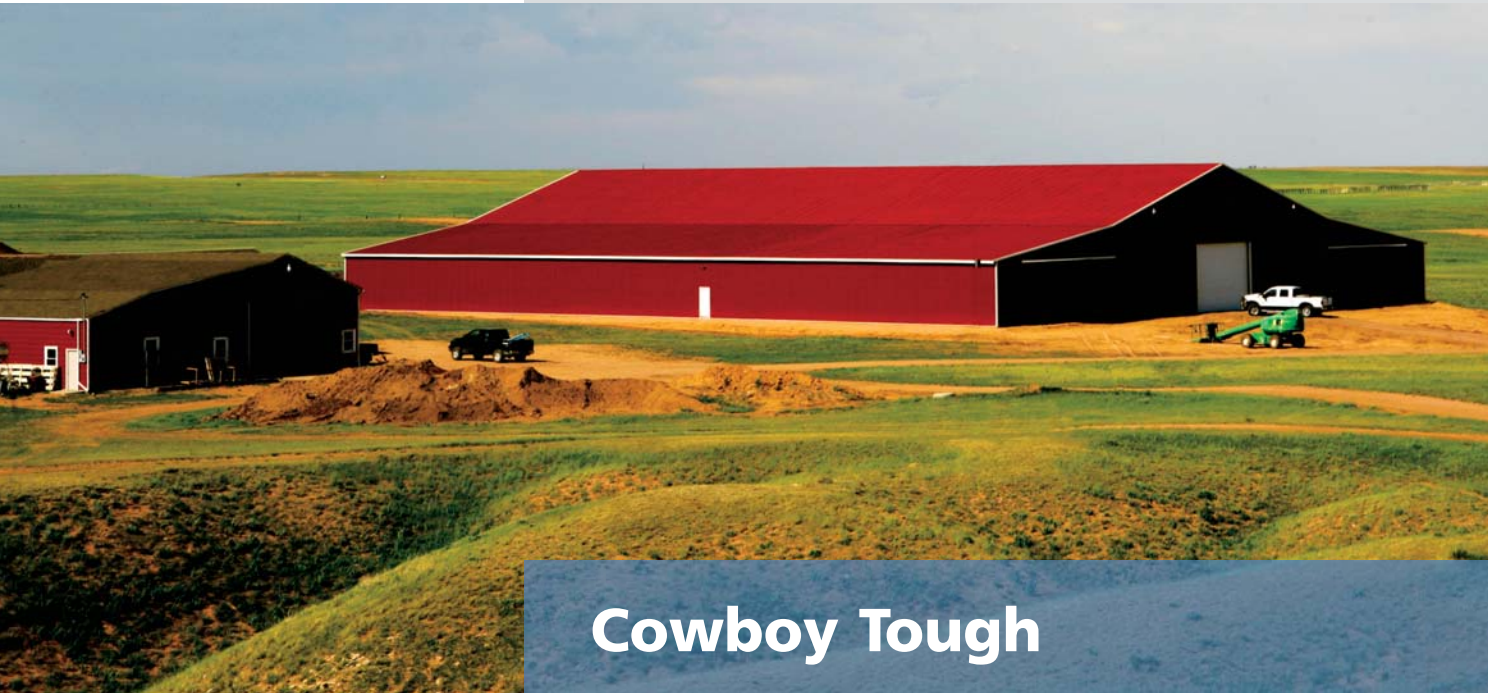

Cowboy Tough

APPLIED SCIENCE

Dura Coat's team of resin experts made sure this 20,000 sq. ft. arena is as rugged as the Cowboy State. Ceranamel™ helps it withstand Big Wyoming weather.

MOTHER NATURE CAN BE BEAUTIFULLY SERENE IN CHEYENNE, WYOMING. But summers can also reach past the 100s, and in winter, Arctic winds can drop temps into the minus-50s. Even for cowboys, that's tough. Add in intense UV light from the 6,000 ft. altitude, plus an animal environment, and this horse arena faces some demanding conditions. That's why Ceranamel™ XT40S from Dura Coat Products was specified. It was made for tough jobs by resin experts whose only focus is coil coating, not house paint or spray cans of craft paint.

Ceranamel™ produces a ceramic/porcelain-type finish that is harder and more resistant to abrasions and stains than conventional coatings. It also applies fast, and with an excellent hardness/flex ratio and internal lubricants, handles the toughest roll-forming applications and readily covers primed hot-dipped galvanized, zinc-aluminum alloy steel, and aluminum substrates.

Ceranamel™ uses Cool pigments and complies with Cool Roof Rating Council, Energy Star and LEED 29 standards, and helps environments by reducing the carbon footprint.

For Cowboy-tough protection of your buildings, be it hot sun or bitter cold, call Dura Coat at **951-341-6500** for more information.



DURA COAT PRODUCTS, INC.

RIVERSIDE, CALIFORNIA
(951) 341-6500

HUNTSVILLE, ALABAMA
(256) 350-4300

www.duracoatproducts.com

Circle Reader Service #581



DYNAMIC FASTENER

DYNAMIC FASTENER

GOLD KEYS WON: 27

W: www.dynamicfastener.com **P:** 800.821.5448



What is the definition of long life? The answer varies greatly depending upon the subject. For instance, an African elephant on the Serengeti has a substantially longer life than a mosquito on your forearm.

Unfortunately for the contractor, the same nebulous and misleading signals are sent when some of Dynamic Fastener's competitors claim that their fasteners have a long life coating. Once again, "long life" is just a relative phrase.

To eliminate unnecessary concerns on behalf of its valued customers, Dynamic Fastener quantifies the meaning of "long life." Since Dyna-Coat premium screw coating passes the 1,000-hour salt spray test, the company proclaims "1,000 Hour" right next to the word Dyna-Coat. Rarely, if ever, does Dynamic Fastener see its competitors touting the tests that its screws pass. That is a suspicious omission.

To paraphrase the famous commercial, "What's on your fastener?", removing the uncertainty on this very important topic is easy. Specify Dyna-Coat 1,000-hour salt spray premium coating on all screw requirements.

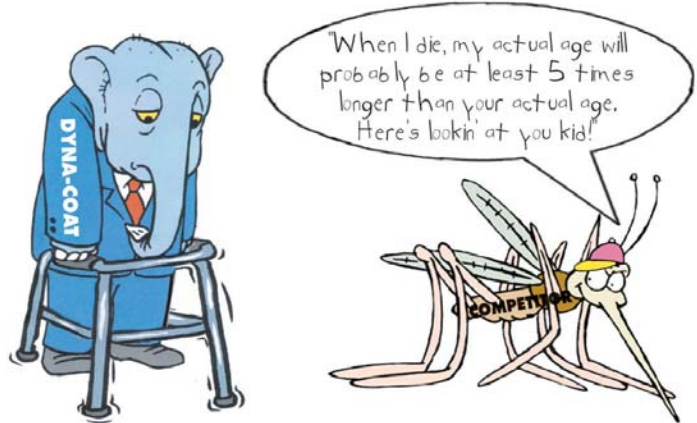

Just because they SAY it doesn't make it true. Make our competitors quantify their coating's life expectancy in WRITING – as we do without even being asked.

Dyna-Coat is a premium organic polymer coating designed to provide corrosion resistance for metal fasteners. Fasteners that are coated with Dyna-Coat exhibit excellent resistance to mar- rying, chipping and abrasion. The color of the coated fastener is metallic silver. Dyna-Coat employs several forms of corrosion resistance, such as replacement, inhibition, envelopment and electro- chemistry. These coated fasteners also have strong resistance against acid and alkaline chemicals.

SERVICE

Dynamic Fastener is proud to earn its 27th straight Gold Key of Excellence Award. That devotion from *Rural Builder* readers is no accident. The company's success rests on its dedication to service, evident in the following areas.

- Orders received by 3 p.m. CST will ship that day more than 99 percent of the time.
- Dynamic Fastener's buying power enables it to competitively and success-

fully sell nationwide. The company has more than 50,000 customers representing all 50 states and 15 foreign countries.

CATALOG

Dynamic Fastener's free 132-page full-color *Tool and Fastener Hand Guide* covers fastener applications, engineering data, availability of types, size ranges and fastener materials. In addition to discussing screws and anchors, the guide provides prices and other information relating to flashings, sealants, insulation tapes, safety equipment, hand tools, power tools and more. **RB**

The cover of the 2015 Tool & Fastener Hand Guide features the Dynamic Fastener logo at the top, followed by the tagline "Everything for the Metal Builder & Roofer". Below this is the title "2015 TOOL & FASTENER HAND GUIDE" and a sub-headline "Over 99% of standard orders received by 4:00 p.m. CST will ship that same day!". The cover displays various tools and fasteners, including a power drill, a screwdriver, and several types of screws. At the bottom, there is a list of regional offices and contact information.

A yellow graphic with a large black number "7" in a white circle, followed by the text "DYNAMIC FASTENER LOCATIONS:". Below this, seven numbered locations are listed in two columns.

1. Raytown, Mo. (Main office)
2. St. Louis, Mo.
3. Memphis, Tenn.
4. St. Paul, Minn.
5. Houston, Texas
6. Melrose Park, Ill.
7. Las Vegas, Nev.



DYNAMIC FASTENER

Everything for the Metal Builder and Roofer

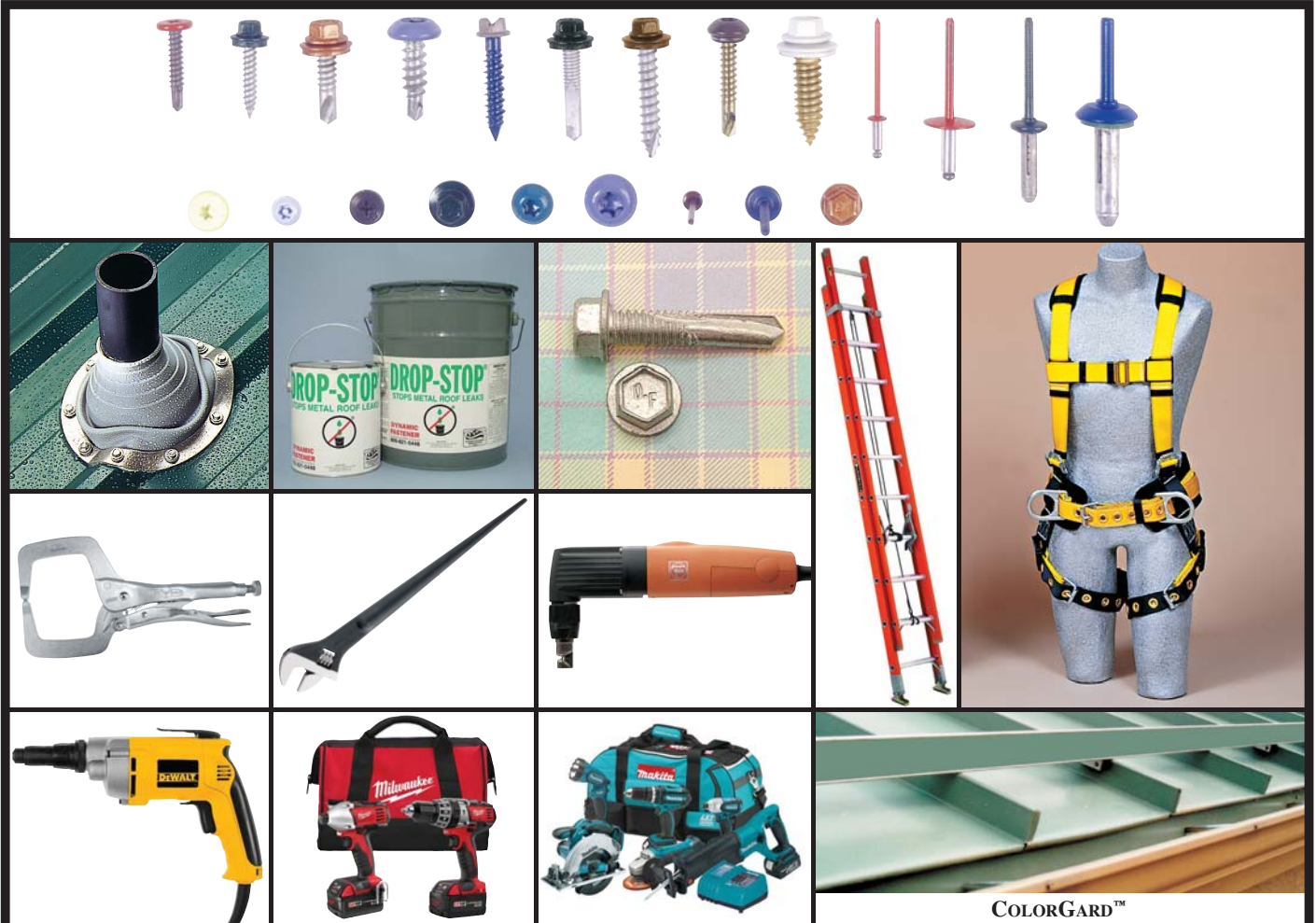

FREE 132 Page Full Color Tool & Fastener Hand Guide provides prices, engineering data & details product offering.

DYNAMIC FASTENER is specifically geared to handle the needs of the Metal Building Contractor. We provide in-house custom color painting of screws and rivets with just a one or two day (days, *NOT* weeks) lead time. **THOUSANDS** of power tools are stocked and sold at the lowest prices. Highest quality, top name brand fasteners are stocked and sold at the lowest prices. Same day shipment on orders received by 4:00 p.m. CST. We are a supplier to the largest metal building manufacturers.

We want to be **YOUR** source for screws, anchors, flashings, colorgard, safety equipment, hand tools, power tools and accessories.

7 warehouses to serve your construction needs for tools and fasteners

(MAIN OFFICE)
Kansas City • Chicago • Houston • Las Vegas • Memphis • St. Louis • St. Paul

CALL 800-821-5448 or FAX 800-844-1199

Call for your Free Full Color 132 Pg. Hand Guide. Better yet, call us for your next tool or fastener requirement. Discover for yourself why your peers enjoy doing business with our company!



EVERLAST ROOFING INC.

GOLD KEYS WON: 13

W: www.everlastroofing.com P: 888.339.0059



Exciting things are happening

■ Promising the thickest steel in the light gauge market Everlast Roofing continues to offer a 27 gauge panel that is noticeably heavier with added strength.

This summer, Everlast Roofing will be offering a new series to join the line of its 27 gauge offering. Launching in July is the new “Wrinkled Series.” This series will provide the end-user with a textured paint finish in either the Everlast II or Everloc Profile. This finish will help create a surface that has a timeless appearance, is tough and provides a scratch resistant surface. In addition, the series will bring advantages that include a low gloss finish, high durability SMP, eight standard in-stock colors and a 35 year warranty.

For almost 20 years, Everlast Roofing Inc., has acknowledged its role as an innovative leader in the metal roofing and siding industry. Being driven to manufacture the most innovative and finest quality metal building components in the roofing industry, it proudly serves clientele throughout the New England, Mid-Atlantic and Mid-West regions of the United States.

Everlast Roofing Inc., which prides itself on quality products, invaluable service and competitive pricing, deeply appreciates the loyalty and support of



its valued customers and community. As a way of saying thank you, the company and Everlast employees give back by promoting various events and organizations such as Big Brothers Big Sisters “Bowl For Kids Sake”, “The Color-Run”, Wounded Warrior, and more.

HONORS AND AWARDS

Everlast has received *Rural Builder’s* Gold Key of Excellence Award for 13 consecutive years (2003, 2004, 2005, 2006, 2007, 2008, 2009, 2010, 2011, 2012,

2013, 2014 and 2015) for excellence in product quality and service. The company is the recipient of the Metal of Honor Award from *Metal Roofing Magazine* for 11 consecutive years (2005, 2006, 2007, 2008, 2009, 2010, 2011, 2012, 2013, 2014 and 2015) for consistently high standards in serving the metal roofing industry.

No wonder Everlast has a record of industry leadership with a reputation worthy of the compliments and satisfaction of thousands of customers since its founding. **RB**



The Wrinkled Series

The One Time You'll Actually WANT Wrinkles!

Want a distinguished look from every angle? Everlast Roofing can help! We are introducing a new paint finish that not only protects, it dignifies.

The *Wrinkled Series* provides you a textured paint finish that is available in Everlast's most popular profiles, making this finish an excellent choice for residential and commercial application. Request this series on top of our already proven Everlast II and Everloc panels to create a surface that is tough, scratch resistant and distinct.

Advantages Include:

- Low gloss finish
- High durability SMP
- 8 standard in-stock colors
- 35 year warranty

When you want to add character to an old or new roof ask for Wrinkles. The Wrinkled Series by Everlast Roofing Inc., Our Name Says It All!



Toll Free: 888.339.0059
www.everlastroofing.com



GRABER POST BUILDINGS

GOLD KEYS WON: 13

w: www.graberpost.com **p:** 800.264.5013



■ **Graber Post has come a long way from building pole barns with a single crew of four men, to now servicing 35 states daily.** The company only provides the best quality products, sells them at a fair price, delivers them on-time, and offers unmatched customer service.

Graber Post Buildings also continues to add to its lineup of products and services. Along with various metal roofing products Graber offers, it is America's Exclusive Distributor of EASY Shake metal roofing. Manufactured by Easy Building Products out of Ontario, Canada, this product is truly an investment engineered to last. This uniform step panel gives all the robust beauty and strength of slate roofing, with a fraction of the weight and install time. It can be custom cut to lengths up to 30 feet, significantly reducing the amount of seams and aiding in the prevention of leaks. This metal roofing panel is ideal for use on both residential and commercial buildings.

Perhaps the most advantageous fac-



tor for customers who visit Graber Post are the post-frame building packages. Graber Post Buildings is indeed a "One-Stop-Shop" for all materials post frame. GPB either manufacturers or distributes every item needed for a total post-frame project, which means a customer can make one phone call and have a total post-frame package shipped right to the job site.

In addition to its 10th consecutive Gold Key Award (13 in all), Graber Post was listed as a top growth company in 2013 within the ProSales Top 100.

Company founder Glen Graber said, "We thank all those who rec-

ommended us for these awards, and we especially thank our many loyal wholesale customers and distributors. We're blessed to be servicing some great people and businesses."

Dating back to 1973, Graber Post Buildings continues to satisfy customers from all over the Midwestern United States with second to none customer service and quality products. The "One-Stop-Shop" philosophy has always stayed true to its word and will continue to do so in the future. Saving customers time and money, time and time again, has been the key ingredient for Graber's success. **RB**



▶ PRODUCTS MANUFACTURED AND/OR DISTRIBUTED BY GPB

Roll Formed Metal – G-Rib, Commercial Grade, Standing Seam

3-Ply Laminated Posts

Wholesale Steel Coils

Metal Trim – Standard and

Custom Pieces

Custom Truss Plant – Trusses up to 100' span

Doors – Entry and Overhead

Windows

Insulation

Metro Steel Shingles

EASY Shake Metal Roofing

Fasteners and Accessories

Complete Building Packages – One Call Does It All



MISSING A PIECE OF THE PUZZLE?

Contact us today and grow your business with us!

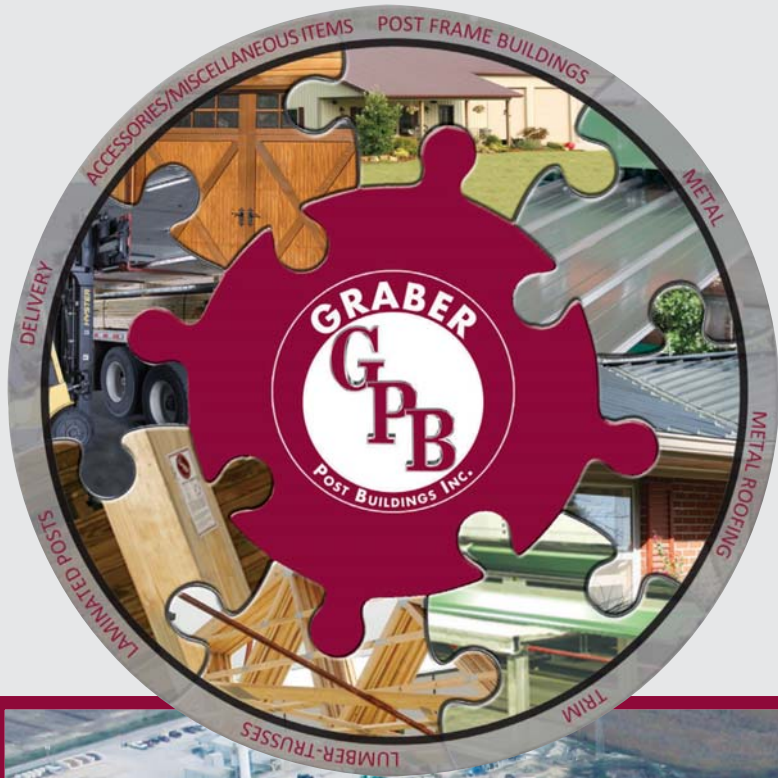

Save time and money and get all post frame materials in one ideal stop!



Graber Post Building Ins.
7716 N 900 E | Montgomery, IN 47558 | 800-264-5013 | graberpost.com

Circle Reader Service #433





LELAND INDUSTRIES

GOLD KEYS WON: 14

w: www.lelandindustries.com **p:** 800.263.3393



More than screws!

WE DID IT! Leland Industries Inc. (est. 1984) has completed the 55,000 square foot addition to our flagship location. We are now 205,000 square feet of manufacturing, warehousing and head office space, in support of our many customers and six satellite sales and warehouse branch locations. From a 2,000 square foot location in 1984, Leland has grown a hundredfold. We were domestic producers then and continue to sell the fasteners that we make. Our slogan, “North American Steel, North American Labor,” is still a valid statement.

The additional space will allow the installation of two more powder coating lines, an improved and enlarged quality control laboratory, expanded bolt making capability, improved packaging facilities and increased warehouse space.

The accompanying Leland advertisement is not what you usually see from Leland. We wanted you to know that we are more than just screws for post-frame construction.

BUYING DOMESTIC PRODUCT SAVES YOU MONEY.

Yes, locally-made products do save you money. Importers are not innovators. When was the last time you purchased a new, improved product from an importing supplier? Never! Domestic manufacturers invest in development time, ensuring that quality is built into the product. They stand behind what they produce and

make job site calls when a problem arises. They’ve “got your back”! Having a problem with an import? Can you name one Asian manufacturer of fasteners? When things go wrong, who do you call? Think about it!

Leland Industries, like most North American manufacturers is proud of its products. Since inception, Leland has introduced a constant stream of new products, some of them patented, all of them designed to make you more efficient at what you do, and ultimately more profitable:

- #10 diameter Master Grippers, because they give better holding power
- Flow-cone washers because they seal better
- One-steppers that bore an oversize hole in fiberglass materials to allow for contraction and expansion, with no cracking
- JS1000 plating, a Leland exclusive, lasts 1,000 hours in salt spray testing with *no red rust*
- Powder coating, the original powder coating, available in over 120 colors, and the only powder coating with a written performance warranty available

SO... WHAT'S NEW AT LELAND?

Did Leland need to add 50,000 square feet of manufacturing space to make more of what it was already making? Yes, partly, but did you know about its increased bolt making capability? Well, Leland has been the major producer of agricultural bolts and nuts from the beginning, but now you should know that it has added new equipment to allow it to make bolts to 3/4-inch x 6 inches in length and, as always, it is one of a very few domestic producers making nuts: finished hex nuts, serrated flange nuts, heavy hex

nuts, and square nuts. Bolts are made in any grade, and nuts sized and plated to allow “Spin-Fit” assembly. All bolts, nuts and screws are available in carbon steel or stainless materials.

Did you also know that Leland bought another fastener producer? Canadian Threadall Limited is now a part of Leland Industries. Operating as a separate entity, Canadian Threadall makes anchor bolts, U-bolts, J-Bolts, bent metal shapes, threaded rod, Acme threaded product, and is capable of threading up to 4-1/2 inches in diameter steel.

Maybe you don’t need all these capabilities to build a wood frame structure, but isn’t it good to know that a source exists for these products just a phone call away?

JUST A PHONE CALL AWAY, THAT'S IMPORTANT.

Offshore producers aren’t a phone call away. But then, you probably already knew that. Leland believes in placing product in strategically located warehouses to expedite delivery, to have back-up product ready for you, to provide “peace of mind” that the job is going to flow smoothly, without embarrassing delays. Here is the contact information for your area: St. Paul, Minn.: 1-800-388-3043 / Fax: 651-484-2778; Kansas City, Kan.: 1-888-292-6166 / Fax: 913-894-4925.

LELAND THANKS YOU

Leland is proud of 14 consecutive Gold Key awards and would like to say “Thank You” to all users of its North American made fastener products. Leland Industries is a responsible producer. Its Quality Control Laboratory is accredited to ISO/IEC 17025. Leland has been rewarded for dedication to “quality and service” by being “single sourced” by the agricultural storage industry for the past 30 years.

That’s a unique accomplishment. RB

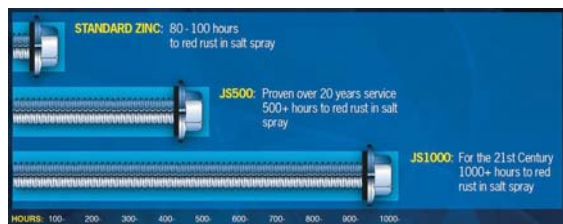

Enjoy the reliability of
100%
NORTH AMERICAN

SPECIAL BOLTS - ANY GRADE UP TO 3/4" X 6"

TANK BOLTS

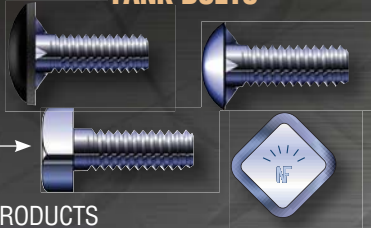

NEW PRODUCTS

- INDENTED SQUARE HEAD CHIME BOLT
- ENCAPSULATED HEAD TANK BOLT

SERRATED FLANGE LOCKING BOLTS



CULVERT & GUARD RAIL FASTENERS



BOLTS & STUDS

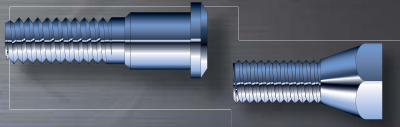

A325 STRUCTURAL BOLTS

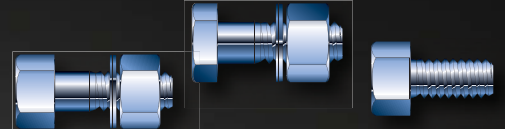

1/2" TO 1-1/2" DIAM. FOR ALL STRUCTURAL FRAME ASSEMBLIES - FULLY THREADED
 ALSO AVAILABLE: HILLSIDE AND BEVEL WASHERS

RIBBED & SMOOTH NECK CARRIAGE BOLTS



KNURLED NECK BOLT

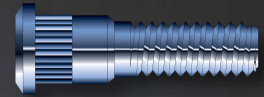

WE MAKE NUTS - available in carbon steel & 304-316 stainless steel



WE OFFER CUSTOM THREADING

With the acquisition of Canadian Threadall Limited., Canada's largest custom threader, Leland can offer you a complete variety of quality threaded products in most ferrous and non-ferrous metals.

- Reverse engineered products from broken or failed samples
- Threading up to 4-1/2" cut and rolled thread
- Thread milling to 16"
- Threaded rods in stock up to 3" diameter in all grades of material
- Bent and formed parts to 4" including "U", "EYE", "J" and "L"

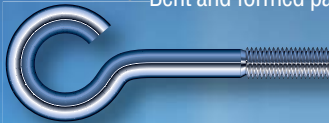

1-800-263-3393 • www.lelandindustries.com

100% North American Made



LEVI'S BUILDING COMPONENTS

GOLD KEYS WON: 6

w: www.levisbuildingcomponents.com **p:** 877.897.7020



■ **Founded in 1978, Levi's Building Components has grown from humble beginnings to being recognized as a national metal roofing product supplier.**

Levi's is known for quality products, quick shipping and accurately filled orders. As a wholesale supplier, Levi's is one source for all metal building fasteners, snow guard and accessory needs.

During the past two years, Levi's has expanded both its warehouse and office space. "We've added 12,000 square feet," says Eli King, Jr., Operations Manager. "We now have plenty of space to stock our most popular items and speed shipping of our product to our customers."

In addition, Levi's continues to be pro-active in the building industry by upgrading warranties on three of its leading fastener products, Fastgrip™ Stainless Steel, ProZ™ and Pro-Cap™.

Two of its fasteners for metal to metal and metal to wood installations, Fastgrip SS and ProZ now feature a 50 year warranty. In addition, a 25 year warranty has been added to the ProCap line of metal to wood screws.

The company shows commitment to quality in the fastener line by continuing a manufacturing process that protects the integrity, strength and true size of the product. Warranty upgrades reflect confidence in ensuring a quality product for its customers.

Match the exact color of your roof to both fasteners and snow guards or choose from 40 plus quick ship color options.

Levi's snow guards are the perfect choice for snow retention and long lasting quality. There are plenty of options with Levi's Snow Defender™ series in several styles. Take advantage of the huge inventory and quick delivery. Levi's offers six different designs in powder-coated stainless steel or clear UV-stable polycarbonate.

Choose from the 4500 or 1500 series, for



Products from Levi's were used from start to finish in the construction process of this new pole barn, ones you can't even see. Levi's is one source for all metal building fasteners, snow guard and accessory needs.

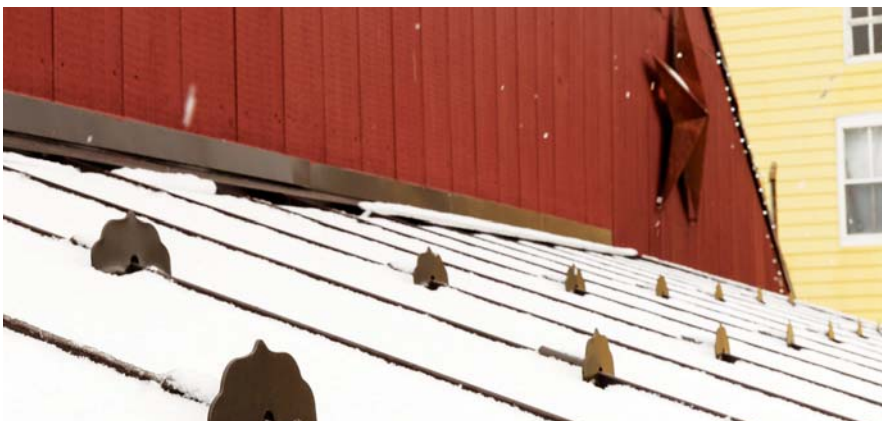

The advantage of the 55RF Snow Defender™ is that it aligns correctly on the seam using popular clamp systems like the S-5!™.

exposed fastener panels and the 6500 and the new 55RF series for standing seam roofing. The new 55RF product is the most versatile snow guard on the market. Designed to be part of a two-part installation system with any of the most popular clamp systems like the S-5!™. The advantage of the 55RF Snow Defender is that it aligns correctly on the seam connection every time.

The metal Snow Defender series comes with Levi's 15 year warranty and each color is powder-coated using a super-tight adhesion process to ensure fade resistance.

Find roofing underlayment, venting,

sealing and more at Levi's. Other new products for 2015 include Wedge Anchors and Metal Wrap. Levi's can consolidate your roofing accessory orders to one stop. By keeping freight costs as low as they can with timely shipping, Levi's aims to meet all the building needs of its customers.

"Adding the additional warehouse will help us pull orders more effectively and we continually add new items to our line to widen our offerings," says owner and founder Levi's son, Steve Fisher. "We have positioned ourselves to service our customers to the best of our ability, now and in the future, with quality products." **RB**



CONSIDER THE BEST

Levi's Building Components is a nationally recognized metal roofing products supplier, for all of your wholesale supply needs. We specialize in snow guards, wholesale screws and accessories for metal roofs. Our metal roof supplies are vast, and you will love our prompt shipment and quality metal building components.



Snow Defender™ 55RF
The most versatile snow guard for standing seam roofing. Aligns squarely every time.

Snow Defender™ 4500
Designed for exposed fastener panels on 2x4 purlins. Now 40% more rigid!

Snow Defender™ PC240
An all polycarbonate snow guard. Almost invisible.



ProZ™
ProZ's washer head reduces overdriving and the head will never red rust with the zinc aluminum alloy cap.

Fastgrip™
Ensure a superior metal to wood grip by using a Hi-Lo thread screw with bonded EPDM washer.

Pancake Head
Designed to fasten standing seam clips: metal to wood or metal to metal.

For more information or to find your local sales Rep, call (877) 897-7020 or visit www.levisbuildingcomponents.com



MAZE NAILS

GOLD KEYS WON: 32

w: www.mazenails.com **p:** 800.435.5949



■ **Maze Nails is proud to be named a Gold Key winner for 32 years and to celebrate 167 years of serving the building and post-frame industry.**

In business since 1848, Maze is one of the few remaining nail manufacturers still producing nails in the USA at its plant in Peru, Illinois.

Maze offers a full line of specialty nails in bulk for hand driving and in collated sticks and coils for pneumatic nailers. Maze has been serving the post-frame industry for many years, providing rubber washer nails, gutter spikes, joist hanger nails, hardened and threaded post frame nails, roofing and siding nails. In addition, Maze manufactures nails for fiber cement siding products, cedar and redwood sidings, fencing and decking.

Maze Nails meet the ASTM F1667 - 05 for post frame ring shank nails. They are also approved and recommended for use with the new treated lumber. All Maze STORMGUARD® ring shank roofing nails are widely used in many coastal areas where high corrosion-protection and high wind uplift resistance are needed. Maze roofing nails withstood and



ABC news anchor David Muir holds a box of Maze Nails during a "Made in America" segment.

exceeded the ASTM G85 test protocol required for the important Miami Dade County approval and comply with the Florida Building Code including the High Velocity Hurricane Zone.

Maze Nails is the exclusive manufacturer of Stormguard Double Hot-Dipped Galvanized Nails with a lifetime warranty against rust. Meeting and exceeding ASTM A-153 spec., the exclusive Stormguard process insures the thickest, most uniform coating of galvanizing available. Maze has over 100 years of hot-dip galvanizing experience and also offers a full line of stainless steel nails.

According to Roelif Loveland, President and General Manager, "Our customers can count on top-quality nails, excellent customer service and quick dependable shipments."

Here is what some of our customers are saying about Maze Nails.

"A few months ago I was at a frame builder's convention ... and Maze Nails put on a nail pounding competition to showcase their product and to get the attention of by passers ... I was shocked to see that during this competition of brutal pounding that not one single Maze Nail

broke or even bent! I couldn't believe that with all that abuse not a single nail was damaged ... If they held up to a competition like that, they would surely hold up on the jobsite. This is exactly why Northland Buildings has trusted Maze Nails products for years to help us produce the best post frame buildings we can, while using the best products in the business..."

— Aaron Constantine
Northland Buildings, Eau Claire WI

"I started pounding Maze nails over 34 years ago. From what I can tell, you are still producing the same quality nails that we used back then. Why mess with a great product! We look at a lot of things when we evaluate our suppliers. Quality is first. If you compare your product with others you first notice the rings seem to be deeper and hold better than competitors. We also find that the nail does not shatter when driven into hard pine. The neoprene (rubber) washer has held up on our buildings for 40 years. Cost is second. We have always considered Maze cost effective and a great value. Delivery times and correct quantities come in third. Maze ranks high here also. Then we have the intangibles: great people to work with, American-Made, sales support and a company that has been in business forever."

— Scott Walters
Walters Buildings, Allenton WI

Call or visit the website for information or free samples. **RB**



Maze Nails' annual nail pounding competition proves how tough their nails really are.

► KEY PERSONNEL AT MAZE NAILS

ROELIF M. LOVELAND,
President & General
Manager (36 Yrs.)

KIM POHL,
Marketing Director
(22 Yrs.)

LEN KASPERSKI,
Assistant Sales
Manager (18 Yrs.)

LISA MARTIN,
Assistant Sales
Manager (14 Yrs.)

JAMIE KREISER,
Assistant Sales
Manager (9 Yrs.)

KYLE LOVELAND,
Assistant Sales
Manager (7 Yrs.)

Quality you can ...

TRUST



**YOU GET WHAT YOU PAY FOR ...
IT PAYS TO BUY MAZE!**

**DOUBLE HOT-DIPPED
GALVANIZED
ULTIMATE CORROSION
RESISTANCE**

NAIL IT ONCE. NAIL IT RIGHT.®



**MAZE
NAILS**

Building
America
one NAIL
at a time

**1.800.435.5949
mazenails.com**

Division of W. H. Maze Company
Helping to build America since 1848

100%
made in the
USA



Circle Reader Service #306



NATIONAL HARDWARE

GOLD KEYS WON: 21

w: www.natman.com p: 800.346.9445

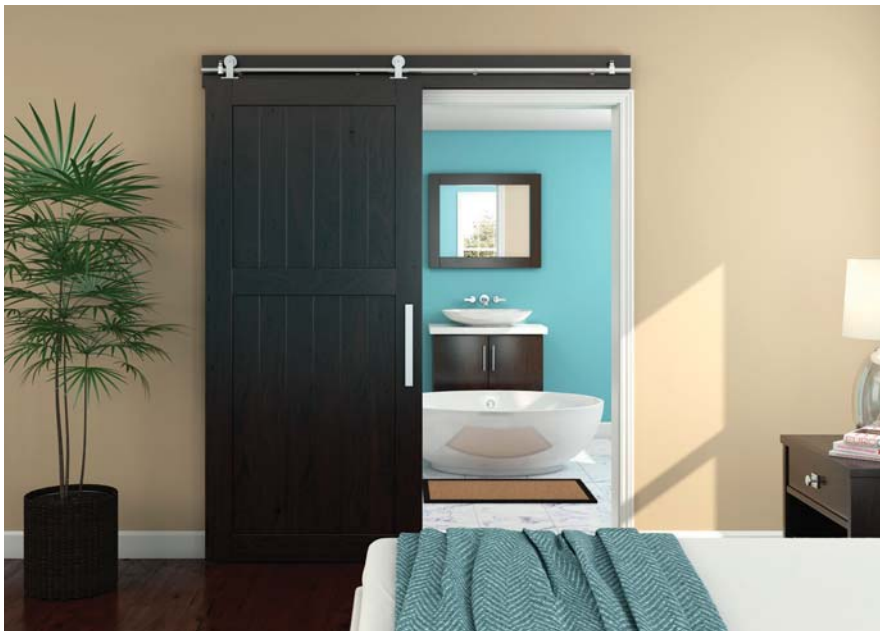

4 Ways to use interior Sliding Doors:

- + Replacing pocket doors between bathrooms and closets
- + Installing sliding doors to provide privacy for home offices
- + Installing twin glass sliding doors to separate the kitchen, dining room, or living room
- + Installing sliding doors in small bedrooms or throughout contemporary style homes

National Hardware Introduces a New Line of Decorative Interior Sliding Door Hardware

■ National Hardware's new line of decorative interior sliding door hardware is a cost effective solution for homeowners who want to create a custom look themselves. Perfect for bedrooms, bathrooms and other living spaces, interior sliding door hardware is quickly becoming one of the more popular trends in the design and do-it-yourself communities.

The sliding door hardware functions like pocket door hardware but with a more decorative appeal and allows homeowners to upgrade their interior openings from a traditional door to a more contemporary, barn door style.

The interior sliding door hardware kits are available in two styles, rustic or contemporary, providing all the necessary hardware to hang decorative interior sliding doors. National Hardware's interior sliding door kits are stylish and high quality; designed and tested to follow ANSI/BHMA Grade 1 standards.

To learn more about National Hardware's decorative interior sliding door hardware, go to www.natman.com. **RB**



INTRODUCING DECORATIVE INTERIOR SLIDING DOOR HARDWARE



Perfect for bedrooms, bathrooms and other living spaces

Offered in oil rubbed bronze and stainless steel

Designed and tested to follow ANSI/BHMA Grade 1 standards

Kits include 72" track, hangers, doorstops, anti-jump discs and floor guides

National
Hardware™

www.natman.com



10651_SN



NORTH STAR METALS

GOLD KEYS WON: 9

w: www.northstarmetals.com p: 888.279.3322



■ **North Star Metals, which started in 1995 as a manufacturer of metal roofing, siding and components, has grown steadily while maintaining a reputation for unmatched quality and service.** The North Star philosophy is two-fold: strive to fully satisfy the customer's needs, and always invest in the most advanced technologies and techniques to improve the entire range of products offered. With that in mind, North Star expanded into the architectural market with the founding of the Architectural Division of North Star Metals.

Panels – North Star's panel offering has greatly increased with the establishment of the Architectural Division. Now in the product lineup are 1-1/2 inch snap lock standing seam panels, in both clip and nail leg profiles, that are cut to length, pre-notched and taper cut to provide significant job site time savings. Tapered and curved (radius) snap batten panels have also been added to the product line, as well as a 1-1/2 inch mechanically seamed panel. These panels have proven themselves to be a perfect complement to North Star's existing offering of panels, which serve the siding and roofing needs of the commercial, industrial and agricultural markets.



Many of these products are offered with North Star's Integral Condensation Control fabric adhered to the panel, as well as being warm-formed to achieve the maximum lifespan potential of the paint system. Panels are available in a range of materials from copper to stainless, and are available with Valspar Fluoropon and Weather XL paint systems in a wide variety of colors.

Soffit – North Star has also added roll-formed and cut-to-length soffit solutions to its product lineup. Both V-groove and flush wall panel soffits are available in vented and smooth profiles up to 16 inches in width. These products are offered with aluminum and steel substrates.

Gutter – Also from North Star is a mobile gutter roll forming machine that enables North Star to provide on-site seamless gutter service. This machine produces a 7-inch commercial flange back and straight back gutter in aluminum or steel substrates with a variety of color options.

Trims – North Star's Architectural Division has greatly increased the offerings of dedicated architectural folded products. These include not only the standard trims and flashings for roof details, but also fascias and extenders with splice plates.

Edge Metals – The Architectural Division also brings ES-1 Certified edge metals and copings to the product lineup. These products serve a wide range of needs with multiple profiles and cleat retention systems.

Welded Products – Enhancing the lineup further yet is the addition of welded and post-painted products to provide watertight miters, transitions, collectors and end-caps for edge metals as well as gutter. North Star also offers custom welded solutions to fit any cladding need.

Custom Folding – Two additional CNC brakes have been added to complement the Jorns Twinmatic folder, and the combined capacity ensures the ability to meet the customer's custom folding needs as North Star grows. The field-experienced, highly skilled operators of these machines are capable of producing excellent accuracy on one-off parts, as well as the consistency needed for higher quantity production. This combination affords North Star the ability to create any panel, trim or part that a customer may require. Whether designing new solutions or creating exact matches for existing products, the job can be painless with assistance from the employees of North Star.

Custom Slitting/Blanking – North Star has the in-house ability to accurately slit and recoil or blank a wide range of materials and thicknesses, whether from its own broad material offering or from a customer-supplied coil.

Delivery – North Star is increasing its specialized fleet so as to serve its customers even better than before. It aims high with a professional, well kept, custom designed fleet so that it may satisfy its customer as well as *their* customer with available job-site delivery. Moffett-equipped tractor-trailers and roll-off capable one-ton trucks deliver product exactly where it is needed with the goal to do its part in maximizing job site efficiency.

A responsibility to the customer to provide unsurpassed service from quote to delivery is the leading principle by which North Star is driven. This is because North Star believes that customer satisfaction is paramount in business. Customer service, beyond providing a first rate product, has been essential for all past successes and will be especially vital for North Star's future growth.

North Star wishes to thank those that helped the company earn this Gold Key award. **RB**

Best Products, Best Service

(No hot air required.)



At North Star, we will always strive to provide products of the best quality with service to match. To do this, we carefully grow our company while investing in the best and most advanced tools to aid our helpful sales staff, field experienced production operators and professional delivery crew. This is done to ensure that we can achieve a level of service and quality that we are proud to provide. Our diverse product line shows the same level of care for the customer, with features that provide time savings on the jobsite that add to the value of our products without sacrificing performance for the end user. Call us today to discover how these features can benefit your next customer's project and your bottom line.

Contact us today to learn more;
PO Box 309 Gnadenhutten, OH 44629
Toll Free 888-279-3322 · Fax 740-254-4282
www.northstarmetals.com



**NORTH
STAR** METALS
MFG. CO.

PLYCO

PLYCO CORPORATION

GOLD KEYS WON: 33

W: www.plyco.com P: 800.558.5895



■ Plyco Corporation is honored to have been chosen to receive its 33rd Rural Builder Gold Key of Excellence award. Plyco continues its commitment to providing high quality building products and excellent service for the construction industry.

Since 1951, Plyco has been a leading supplier of products to the post-frame, metal-frame and commercial construction industries. The corporate philosophy at Plyco is to dedicate itself to exceeding customer need and expectations. The company continues its effort toward improvement of this goal through pride in workmanship and service. As a result, Plyco has become a leader in the industry, offering a full line of quality products supported by a direct employee sales team. Its innovative product delivery system provides customers what they need most—scheduled delivery of high quality products at a competitive cost.

Plyco is committed to developing and offering its customers new market-driven products that provide the builder a distinct advantage.

DOORS:

Plyco provides an extensive variety of walk doors and service doors custom built to fit your application needs. Plyco doors are engineered and tested for quality assurance and to surpass building code standards. Plyco offers doors designed for use in agricultural, out building, commercial and light industrial buildings.

WINDOWS:

Builders choose Plyco windows for their durability, reliability and incredible value. The company's line of commercial, post frame and residential windows offer the builder quality options for the building application. Being BUILT PLYCO STRONG means withstanding temperature changes and an annual barrage of rain and snow. A Plyco window must look great, function properly and add real value to its building.

FASTENERS:

East Coast Fastener produces durable, long-lasting fasteners for all combinations of building materials. The company also provides products to solve moisture issues like leaky gaps in roofs or sidewalls by supplying closures and pipe flashings to builders across America.

East Coast fasteners and closures provides the strongest and most effective building components for fastening wood, aluminum, steel, roof deck, plywood, drywall, insulation, gutters, concrete, brick, block and mortar.

PRODUCTS FOR ALL BUILDING APPLICATIONS:

Plyco also manufacturers and/or distributes a wide variety of cupolas, ridge vents, track and hardware, and horse stall systems. For many builders and contractors, Plyco provides one-stop distribution for the majority of their building component needs. **RB**



► KEY PERSONNEL @ PLYCO CORPORATION

MANAGEMENT STAFF

- Garry Matz** President/CEO
- Fred Mancusi** Director Sales/Marketing
- Jim Drees** General Manager
- Al Geisthardt** Engineering Manager
- Jim Pohilla** Business Development Manager
- Kyler Pope** Marketing Manager

INSIDE SALES COORDINATORS

- Barb Isely
- Ann Willmas
- Diane Mattes
- Becky Rechlicz
- Patti Reineking
- Nicky Skelton
- Renee Schmidt

COMPANY LOCATIONS

- Elkhart Lake, WI
- Shawano, WI
- Walkerton, IN

Build **PLYCO** Strong

SINCE 1951



BUILD PLYCO STRONG



- DOORS • WINDOWS • FASTENERS & CLOSURES
- CUPOLAS • COMPONENTS • STALLS • INSULATION

Since 1951, Plyco has stood by you and by their products. Plyco offers a complete line of products that surpass building codes and customer expectations. At Plyco, we've become the leader by delivering the quality products you and your customers demand. **Build Plyco Strong.**



PLYCO

CORPORATION

800.558.5895 • Fax: 800.257.5926 • www.plyco.com • Elkhart Lake, Wis.

Circle Reader Service #313



STEEL DYNAMICS

GOLD KEYS WON: 4

w: www.steeldynamics.com p: 800.799.8942



Steel Dynamics Announces Planned Paint Line and Galvalume® Capability Expansion

■ **Steel Dynamics has announced plans to expand its offering of value-added flat roll steel products through the addition of painting and Galvalume capabilities at its Columbus, Mississippi steel mill.**

The most significant portion of the expansion will be the addition of a state-of-the-art continuous coil paint line with an annual coating capacity of 250,000 tons. Operations are expected to begin during the first quarter of 2017, based on an 18-month project timeline. The Columbus paint line will utilize an improved design similar to the company's existing two lines located in Indiana.

The investment is a strategic step toward the Steel Dynamics Flat Roll Division's further diversification into offering value-added products. The additional width capability and vacuum degassing equipment will enable the Columbus facility to further broaden its

pre-painted product offerings by physical aspect and geography. Steel Dynamics currently has two paint lines and the ability to produce Galvalume steel in Indiana; however, the Columbus investment will allow the steelmaker to produce double-wide steel, and sell into the southeastern markets, including Mexico.

The expansion will enable the Flat Roll Division to sell surface-critical, appliance-grade steel, as well as construction related products, including those used in heating and air conditioning units, residential entry doors, and lighting fixtures.

This growth project also includes the addition of equipment to an existing Columbus galvanizing line to enable production of Galvalume, or aluminum-zinc alloy coated flat roll steel. The combination of aluminum and zinc significantly enhances corrosion performance and solar reflectivity, making it



the material of choice for premium metal roofing used in construction.

Steel Dynamics is the only domestic steel company to have a contiguous paint line at a production location, offering painted steels directly to the customer. As a result of its supply chain efficiency, customers benefit from reduced logistic, administrative and inventory carrying costs.

Steel Dynamics, Inc. is one of the largest domestic steel producers and metals recyclers in the United States based on estimated annual steelmaking and metals recycling capability, with annual sales of nearly \$9 billion in 2014, and manufacturing facilities primarily located throughout the United States, including six steel mills, eight steel coating facilities, two iron production facilities, over 90 metals recycling locations and six steel fabrication plants. **RB**





With the addition of our paint line and Galvalume® capacity, Steel Dynamics will have you covered *everywhere.*



Steel Dynamics is proud to announce our new 72"-wide paint line and new Galvalume® capability at our 3.4 million ton Columbus, MS flat roll facility.

Beginning in early 2017, this major expansion will enable us to better serve our customers in the southern United States, the Plains states, and deep into Mexico. SDI - Columbus will produce a full range of sheet products, including for roofing and siding applications for the component, post-frame and architectural markets.

This will be the ideal geographic complement to our existing Galvalume® and paint capabilities at our locations near Louisville, and in northern Indiana.

As the only domestic steel producer operating its own paint lines, Steel Dynamics is able to offer unique advantages to our supply chain partners by eliminating the long lead times, yield loss and the extra coil handling and logistics costs associated with the toll-painting model... SDI = One-Stop Shopping.

With our growing commitment to this key market, we once again proudly accept the Rural Builder Gold Key Award in recognition of "suppliers who did the best job in meeting the customers' product and service needs." SDI is grateful to our customer partners for their tremendous support. We are here, there and everywhere... for you.



(800) 799-8942
www.steeldynamics.com



SUKUP MANUFACTURING CO.

GOLD KEYS WON: 31

w: www.sukup.com p: 641.892.4222



■ **Sukup Manufacturing Co.** is proud to be a Gold Key of Excellence Award winner for the 31st year. The company is privileged to have spent more than 50 years providing grain drying, storage and handling equipment to protect and preserve the world's grain supply.

Sukup now also manufactures steel buildings to protect the tools that produce that grain supply.

The clear span design of Sukup Steel Buildings allows the interior space to be adapted to your customers' specific needs, whether room is needed to fold out a planter or partitions put up to create an office area, shop or storage area.

SUKUP STEEL BUILDINGS FEATURE:

- Straight or tapered columns.
- Clear span construction.
- Minimum number of interior columns.
- Pre-punched galvanized purlins and girts for a proper fit and faster installation.
- Wide range of exterior and trim colors to choose from.

The seams on Sukup standing seam roofs are mechanically-rolled to create a 360 degree Pittsburgh double-lock seam. This seam creates a tight, durable, virtually leak-proof seal. Movable roof clips allow the roof to expand and contract with temperature changes, preventing stress on the roof components. Sukup also manufactures a screw-down roof that is economical and easy to install.

Sukup Manufacturing Co. is the fastest-growing bin manufacturer in the world. It is also the world's largest family-owned and operated full-line grain handling and storage equipment manufacturer.

Located in Sheffield, Iowa, USA, Sukup has been engineering solutions to protect and preserve the world's grain supply since 1963. Its product line includes farm and commercial grain bins, portable and tower dryers, centrifugal and axial fans and heaters, stirring machines, bin unloading equipment, and bin floors and supports. Sukup also makes a line of material handling equipment that includes bucket elevators, drag conveyors and chain loop conveyors. **RB**

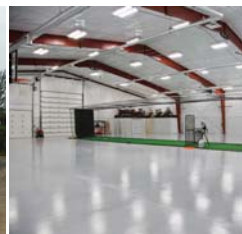

Sukup Steel Buildings



The clear span steel design of Sukup Ag & Industrial Buildings allows them to be adapted to your specific needs. Need room to service a combine or planter? Want room for a shop, storage *and* an office? It can all be done with a Sukup Ag & Industrial Building.

The seams on Sukup Standing Seam Roofs are mechanically-rolled in the field to create a 360° Pittsburgh double-lock seam, so anything you choose to put in your Sukup Building will stay dry and safe. Screw down roofs are also available.

An industrial strength building that's customizable and built to last...

Now THAT'S a Solution™.



2015

R&B



Sukup Manufacturing Co. ■ www.sukup.com

641-892-4222 ■ info@sukup.com

1555 255th St. ■ Sheffield, IA USA 50475-0677

Circle Reader Service #345



VALSPAR

GOLD KEYS WON: 6

w: www.valsparcoilextrusion.com

p: 888.306.2645



■ Since 1806, Valspar has been dedicated to bringing customers the latest innovations, the finest quality, and the best customer service in the coatings industry. Valspar's pioneering paints and coatings have enhanced buildings from residential, commercial, industrial, agricultural, architectural to iconic buildings and the world's best-known brands. As one of the largest global coatings manufacturers in the world, Valspar provides a wide range of coatings in several industries.

Valspar offers a full range of high-performance architectural coatings in PVDF, SMP, and polyester formulas. These superior coatings are available in a full palette of colors and surface textures to meet the most demanding environmental conditions and designs. Fluropon® is their flagship coating, containing 70 percent PVDF resins, offer premium protection against harmful UV rays, chalk, fade, and chemical degradation. WeatherXL™, the next generation enhanced silicone polyester coating, offers even more advanced protection against weathering to ensure that your design lasts for years to come. Looking for performance you can see and feel? Check out Valspar's new WeatherXL Crinkle Finish coating for a new unique textured appearance. These high-quality coatings are extremely durable and have excellent film integrity and adhesion properties.



No matter what building component you need to protect—roofing, wall panels, canopies or fascia systems—Valspar has a coating solution to fit your unique needs. They are here to help you create a lasting impression for you and your customers. Valspar offers the color, confidence and collaboration needed to bring your building project to life.

Valspar understands the important role that color plays in building design. They have color experts that are knowledgeable in color trends, color formulation and color services. Formulating the perfect color demands expertise, laboratory resources and testing proficiencies found nowhere else in the industry. They offer a full palette of colors to choose from or allow them to put their advanced color matching technology to work for you to create your lasting impression.

Valspar provides a superior level of customer service to ensure that your project goes as smoothly as possible. From the color matching process to unmatched delivery speed, Valspar doesn't miss a beat when it comes to completing your project

quickly and successfully while ensuring that it is beautiful, long-lasting, and functional. To do this, Valspar collaborates with your team to understand your project needs and create custom solutions that are guaranteed to perform.

While creating high-performing coatings that meet your needs is Valspar's number one priority, they work hard to make sure that their coatings are environmentally friendly. Valspar has formed strong relationships with several green programs such as the Cool Roof Rating Council (CRRCC), LEED and ENERGY STAR to develop testing methods, set product ratings, and weigh in on critical issues affecting both the environment and the coil and extrusion industry. Regardless of what your highest priority is—eco-friendliness, aesthetic, budget, or performance—every factor should be taken into account when it comes to your project.

The scope of your vision should never be compromised. Which is why Valspar always delivers on a very straightforward promise: *If it matters, we're on it.*® **RB**

Uncoil your vision.



Metal lets you bend your imagination to life. But for all of its flexibility, it will take a tough skin to preserve and protect your greatest accomplishments. Put your trust in the coatings that are engineered to endure the test of time and the elements. And with thousands of colors already formulated, have no doubt we have the right coating for your project. Find out which Valspar product is right for your job. Call 1-888-306-2645 to speak with an expert or visit valsparcoilextrusion.com.



Circle Reader Service #484

valspar
if it matters, we're on it.®



A.J. MANUFACTURING

GOLD KEYS WON: 29

w: www.ajdoor.com p: 800.328.9448



Harmony™ Vinyl Windows and Patented EZ-v™

■ A.J. Manufacturing is pleased to announce that they are now the manufacturer of Harmony™ vinyl windows. By bringing 100 percent of the manufacturing of Harmony vinyl windows in house, AJ is able to eliminate the inefficient and unreliable service associated with buying and reselling windows.

AJ understands the needs of the post-frame industry and is dedicated to delivering the most complete solution possible with Harmony windows and AJ doors.

Harmony windows feature a heavy 3-¼ inch main frame with several internal chambers for greater structural integrity. Built with double strength, 7/8 inch insulated glass, triple weather seal on the sash and a positive interlock, Harmony windows will keep even the harshest of weather out.

Harmony window production might be new to AJ, but not to the dedicated employees who brought more than 120 years of vinyl windows craftsmanship with them to AJ.

Harmony windows are handcrafted, have options that meet current and future energy codes, and are competitively priced.

Available in styles such as single or double hung, slider, casement, bay and bows with optional internal wood grain finishes, Harmony windows are the answer to your vinyl window needs.

AJ's exclusive and patented EZ-v™ vinyl trim and installation system permits the installation of Harmony vinyl windows into steel clad buildings with a fully trimmed panning frame that will accommodate the raised ribs of the building skin.



EZ-v is paintable, easy to install, leak free, tolerant of thermal expansion and contraction and won't require a subsequent application of J-Channel.

The Harmony window with EZ-v vinyl

trim and installation system is the best looking window you could want with the longevity and durability you need. **RB**

Circle Reader Service Card #334



A.B. MARTIN ROOFING SUPPLY LLC

GOLD KEYS WON: 3

w: www.abmartin.net **p:** 717.445.6885



■ **A.B. Martin Roofing Supply is a leading manufacturer and supplier of post-frame building materials, metal roofing and siding.** It is also a nationwide wholesaler of soffit, Sealtite screws, roll door track, double bubble insulation, Ultra-Vent (ridge vent), Uplift Plate (post uplift), glu-lam posts, cupolas, snow guards, S-5! Snow Rails, S-5! Solar Clamps, polycarbonate skylights, Agtuff (pvc



wall and ceiling panels), rot resistant Green Posts, and more! All materials are shipped from the manufacturer or

our warehouse.

We are also excited to now carry the new ZXL WoodBinder screw from Sealtite. A molded zinc-aluminum alloy head provides lifetime protection against red rust on the head and washer. This introduces our first screw with a 40 year warranty.

Everything you need under one roof: only at A.B. Martin Roofing Supply, LLC. **RB**



A. B. MARTIN ROOFING SUPPLY, LLC

Roofing & Siding • Hardware • Lumber

Wholesale Supplier



Cut to Fit Ridge Ventilation

ABM Panel Profile with Glue
2-50' Rolls - 100 Lineal Ft./Pkg.



Ultra-Vent

Conforms to any roof panel!

Compresses and fills every void.
Factory applied glue strips for easy install.

1" wide x 1.5" high x 20' long rolls

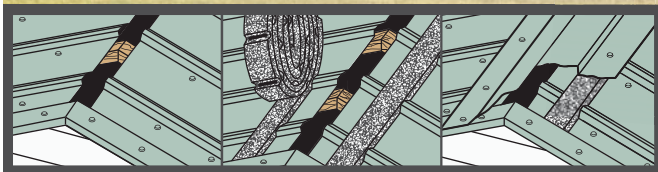
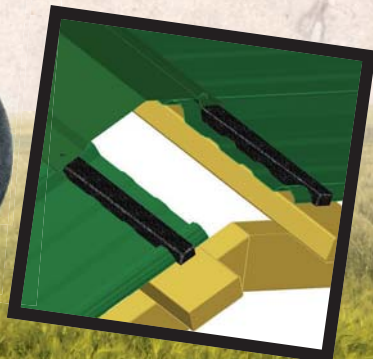

82 Garden Spot Rd. | Ephrata, PA 17522 | 717-445-6885
35 Ridge Rd. | Newville, PA 17241 | 717-776-5951

www.abmartin.net

Circle Reader Service #291



BECKER SPECIALTY CORPORATION

GOLD KEYS WON: 8

w: www.beckers-group.com p: 847.766.3555



BeckryTex

NEW TEXTURED PAINT SYSTEM



Architectural low gloss anti-reflective coating

BeckryTex technology allows you to design unique and distinctive exterior textured finishes. A flexible, low gloss polyurethane coating, it is most often used on roofing for a well defined wrinkled look that creates the appearance of materials other than metal. A wide range of popular colors are available in this weather resistant product.

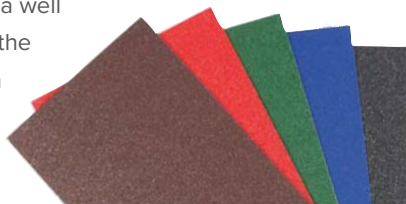

Beyond The Surface



Becker Specialty Corporation

2526 Delta Lane,
Elk Grove, IL 60007
P: (847)766-3555
TF: (800)782-2400

www.beckers-group.com
rob.roy@beckers-group.com

■ **Becker Specialty Corporation is recognized as a leader in custom-formulated coil coatings for metal applications in North America.** Since its founding in 1953, it has succeeded through:

- **Drive and Passion:** In innovation, setting the standard and building the future.
- **Trust and Integrity:** In all its actions, showing respect for employees, customers and the environment.

It furthers its efforts by being:

- **Business Minded:** A strong commercial approach, open to new ideas and results driven.
- **Customer Focused:** For long term mutually profitable relationships.
- **Unified and Working Together:** A transparent and integrated approach, recognizing the company's efforts and achievements.

Known for OT polyester coil coatings, Becker's market focus is on building products, garage doors, office products, heating ventilation and air conditioning, ceiling grid systems and much more.

In 2007 Becker Specialty Corporation became part of Becker Industrial Coatings, a leading worldwide paint manufacturer supplying products to more than 120 countries. Energy Star certified BeckryTech, by volume, is Becker Industrial Coatings' most-used product worldwide for the construction market.

Also widely used in the construction market, BeckryTherm utilizes high-tech, cool roof, organic coating technology. BeckryTherm features solar reflective, ceramic pigmentation to ensure Energy Star-approved solar emissivity and reflectivity for maximum energy savings. Rounding out the Becker product line are BeckryFluor, a full-strength, 70 percent Kynar 500-based coating system for the highest performing exterior building products; and BeckryPol, a range of polyester products custom formulated for stringent coil coating specifications. **RB**

Circle Reader Service #338



CENTRAL STATES MANUFACTURING
GOLD KEYS WON: 20

w: www.centralstatesmfg.com **p:** 800.356.2733



■ **Not all metal is the same.** Better quality metals fade and rust less, are less prone to dents and scratches, and outperform and outlast average materials. Central States Manufacturing, Inc. produces the highest quality metal building components for more than 2,000 post frame, commercial, residential and architectural customers in the United States.

Renowned for its legendary service and accuracy, Central States delivers outstanding quality metal building components that are *Right, On-Time, Every Time*. More than 500 quality control steps make certain that Central States' products and



Renowned for its legendary service and accuracy, Central States delivers outstanding quality metal building components that are *Right, On-Time, Every Time*.

service are the best in the industry.

Central States produces steel roof and siding panels and trim. Purlins, accessories, gutters, windows and doors are also all part of the wide assortment of products available from Central States. An employee-owned company, Central

States works constantly to ensure orders are right, that they are delivered on-time, and that they are consistent every time.

Visit the Central States website at www.centralstatesmfg.com to learn more about the company, its products, and the quality and service behind it. **RB**

Panel Perfect.
Right. On Time. Every Time.™



Find our distributor near you
800-356-2733



www.centralstatesmfg.com



DBCI

GOLD KEYS WON: 3

w: www.dbci.com **p:** 800.542.0501



■ DBCI is honored to receive its third consecutive Gold Key Award and extends a special thanks to its loyal customers and world-class employees, the two driving forces behind this accomplishment.

For more than 25 years DBCI has embraced a culture of quality, customer focus and innovation. The roll-up door manufacturer continues to set the industry standard for excellence.

Growing demand for its new Curl-

Lok® product positions DBCI as one of the most forward-thinking companies in the door industry. Curl-Lok doors are the first sheet doors that can be repaired on-site without the use of any special tools. In the past, a damaged sheet door had to be completely replaced, but Curl-Lok panels slide into place with an engineered curl (patent pending) instead of a permanent seam for a more cost-efficient door.

However, the real secret to DBCI's

success—which isn't a secret to regular customers—is a commitment to service. This company always goes the extra mile for its customers. DBCI doesn't just collect awards like the Gold Key, it earns them with thousands of jobs well done across the country.

DBCI operates production facilities in Douglasville, Georgia; Houston, Texas; and Chandler, Arizona and supports an expanding distribution network across the U.S. **RB**

CHANGE
IS EASY
CURL[®]LOK[™]

In the past, a damaged rolling sheet door meant you had to replace the entire thing. But that was before **Curl-Lok™**.

Now you can replace a single damaged panel fast and at a fraction of the cost. You, your customers and the guy who drives the forklift can all breathe a sigh of relief.

Call your DBCI sales representative at **800-542-0501** or visit us at www.curl-lok.com.

A new innovation from **DBCI**





DIRECT METALS INC.

GOLD KEYS WON: 1

w: www.directmetalsinc.com **p:** 855-800-8878



■ Breaking the mold to provide quality and value.

Direct Metals Inc.'s newest efforts include providing quality American Made translucent panels that are 20 percent up to 93 percent thicker than the competition.

These new polycarbonate sheets, in 1.0mm and 1.5mm thickness, provide specific advantages over the old industry standard of imported 0.8mm thick panels. Benefits include longer warranties and expected product life cycles, product approvals and calculations for wind uplift and snow loads. Installers have noticed that the thicker sheets are considerably easier to install, helping to save time and energy on the job site.

Direct Metals Inc. has made these new thicker panels in 3/4-inch Rib and R Panel available to our nationwide network of panel manufacturers and building products distributors. Please request a free product sample today at samples@directmetalsinc.com and



you too can help spread the word about these great new products. Together we can build stronger buildings while building stronger relationships and stronger reputations. **RB**



Thank you for the honor of the Gold Key, we take pride in providing the fastest shipping times and quality products. Thank you to our valued customers who voted.

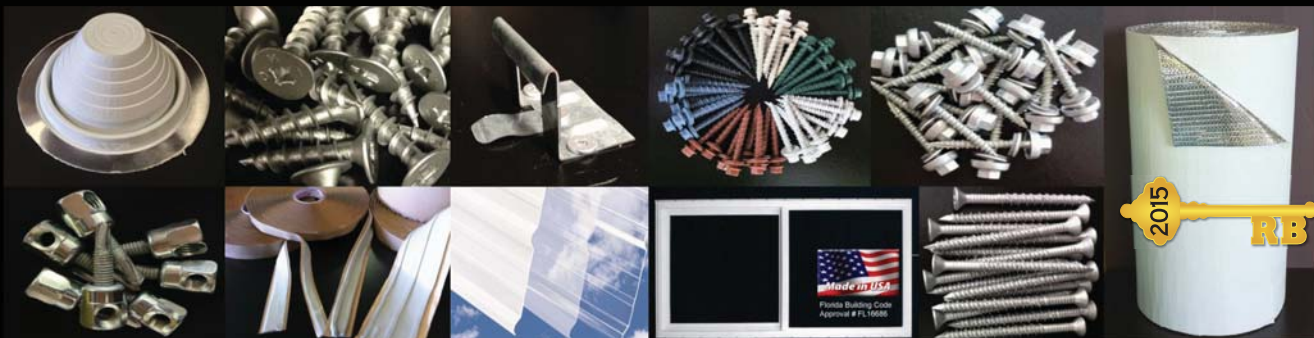

Same day shipping available on millions of in stock fasteners plus, track and trolley, aluminum door rail, pipe flashings, polycarbonate panels, closures, Razorback ridge ventilation, sealants, doors, vinyl windows, rFoil insulation, Bullet Boots, PVC liner panels, Tapcons, anchors, panel clips, and more.

Inventory management programs now available.

www.directmetalsinc.com

ph: 855-800-8878

info@directmetalsinc.com



EDCO PRODUCTS

GOLD KEYS WON: 1

w: www.edcoproducts.com p: 800.593.2680



EDCO expands product lines and choices.

■ EDCO's ArrowLine Enhanced Shake and Slate roofing panels have a new color for 2015 — Statuary Bronze Blend. The additional color brings the number of blended colors offered to a total of six for both product lines. Statuary Bronze solid was also added to the ArrowLine Slate line for a total of five colors. The additions are due to the popularity of EDCO's ArrowLine Enhanced roofing with its distinctive rich multi-tone look and great curb appeal.

ArrowLine panels are versatile enough for use as a roofing panel as well as a sidewall/accent. All panels are backed by an industry-leading fade and hail protection warranty. EDCO's ArrowLine roofing panels were voted *Metal Roofing Magazine's* Top 10 New Products for 2014 and a Metal of Honor four years in a row.

EDCO has also expanded its steel siding line to five ENTEx coated steel siding panels that are available in 14 low-

gloss solid colors and three HD colors. EDCO manufactures a complete line of gutter, soffit and fascia products for your exterior remodeling projects. **RB**

► Watch install videos online at edcotv.com.



THE FOREVER ROOF

ArrowLine
STEEL SHAKES & SLATE ROOFING

2015 RB

METAL ROOFING 2014 TOP 10 PRODUCT

EDCO's ArrowLine® roofing products have received the highest possible hail rating, and are coated with a deluxe KYNAR 500® finish to maximize color retention. Available in a rich range of contemporary colors. ArrowLine® metal roofing carries a **lifetime, non-prorated limited warranty** that is fully transferable with the sale of the home.



800.593.2680

arrowlineroofing.com
edcoproducts.com • edcotv.com

Circle Reader Service #364



FASTENERS DIRECT LLC

GOLD KEYS WON: 4

W: www.fastenersdirectllc.com P: 800.450.3986



Fasteners Direct LLC gives roll formers an advantage with a full line of industry leading parts and award winning service. Their Surloc anti-backout screw pierces a 29 gauge panel faster and installs quicker, and it also looks better than any screw on the market. The same can be said of their FMX line of self-drilling screws with the new NSF drill point.

Fasteners Direct LLC provides one stop shopping for screws, rivets, closure, caulk, Deks brand flashing, CondenseStop condensation control, and strippable film. Everything the discerning roll former needs ships the same or the next day from the middle of America.

Roll formers are encouraged to request samples and see for themselves if the products are better.

They will likely find that they can save money too! RB



Post Frame



Pre-Engineered



You have tried the rest – Now call the **BEST!**



New Washington, IN

Local: 812.293.3606

Toll Free: 800.450.3986

Fax: 812.293.3546



Residential



Accessories

www.fastenersdirectllc.com
wiggs@fastenersdirectllc.com





Protection—in just one layer



CLAD-GARD™ SA-FR with CoreGard™ Technology provides a safer learning environment for our future generations.



Introducing **the only self-adhered UL Class A underlayment** with CoreGard Technology on the market today. CLAD-GARD SA-FR with patented **CoreGard Technology** provides:

- Superior protection from fire and water
- Cost savings on materials and labor
- Quick and easy installation
- And much more

Even in challenging conditions, you can count on Firestone Building Products to keep your building—and the people inside—protected. **Because nobody covers you better.**

Learn more about
**CLAD-GARD SA-FR with
CoreGard Technology today.**
firestonebpc.com/coregard

CORE GARD™

 /FirestoneBuildingProducts
 @FirestoneBPCo

Firestone
BUILDING PRODUCTS
NOBODY COVERS YOU BETTER.™



H&H METAL PRODUCTS

GOLD KEYS WON: 5

w: www.hhmetalproducts.com p: 888.773.8325



H&H METAL PRODUCTS' CORE BUSINESS IS METAL ROOFING AND SIDING PRODUCTS FOR RESIDENTIAL, POST-FRAME AND ARCHITECTURAL APPLICATIONS.

It is a family owned and operated business, and it understands how crucial it is to get the job done right.

H&H Metal Products invests only in the best people, equipment and inventory. State-of-the-art equipment allows H&H Metal Products to produce crisp, clean, uniform products every time. Staff and management at H&H Metal Products boast over 200 years of combined building industry experience.

Check out Condenstop for controlling condensation in construction. This innovative solution continues to gain in popularity. The absorptive membrane is effective and affordable, making Condenstop a must on your next metal roofing project.

H&H Metal Products is proud of its Gold Key of Excellence Award and would like to thank its customers for making it happen: another example of how H&H Metal Products strives to improve its customer relationships. **RB**



CondenStop®

Proven Technology for Controlling Condensation on Metal Roofing

COMBAT
CONDENSATION

Condenstop® is a highly absorbent-layered fleece material containing millions of micro spheres that absorb and contain condensed water. It prevents dripping inside the building until the water evaporates.

Proudly standing behind Condenstop is H&H Metal Products, Inc. Our company manufactures and distributes quality metal roofing and siding products for post-frame buildings, architectural projects, and the ever-growing residential roofing market. We've grown to become a successful company by focusing on one main goal - customer satisfaction.

Others may claim to be customer focused, but at H&H Metal Products the proof is in our reputation. Our production team and sales force have over 100 years of combined experience and expertise. H&H Metal Products takes a great pride in our ability to consistently complete orders accurately and ship on-time deliveries. Contact us today about the latest trends, uses, and advantages of steel roofing and siding products and how these products can be utilized to complete your next project.

- Factory-applied to Metal Roofing.
- Fire resistant and reduces noise.
- Significantly reduces labor costs.
- Performs better than vapor barriers.
- Bacteria and Mold resistant.
- 20 Year Limited Warranty.

CondenStop® is a highly absorbent layered fleece material containing millions of micro spheres that absorb and contain condensed water. CondenStop® prevents dripping inside the building until the water evaporates. CondenStop's® self-adhesive backing is factory applied to all H&H Metal Product's metal roof panels making job site installation quicker.

For more information contact H&H Metal Products at (888) 773-8325
Visit www.hhmetalproducts.com/condenstop

Condenstop® is a registered trade mark of LANTOR Construction Ltd

Circle Reader Service #295

WWW.RURALBUILDER.COM

53



IDEAL BUILDING FASTENERS

GOLD KEYS WON: 9

W: www.idealbuildingfasteners.com P: 800.670.5767



■ Ideal Building Fasteners is once again honored to have its loyal customers recognize its profound commitment to them by nominating Ideal for the Gold Key award.

Ideal was founded in 1994 by its current president, Jay Levy, with the intent of continuing the business philosophy begun with his former company, Guardian Fasteners. This simple philosophy of providing excellent products and service each and every day has contributed to Ideal's growth and longevity in the post-frame industry. Levy states, "Our customers deserve this award – without

them and their support we would be just another fastener company."

Ideal provides a comprehensive line of fasteners, closure strips, venting closures, sealants, pipe boots and other metal building accessories. Its in-house paint facility is capable of custom matching any color of metal panels, unequalled in the industry.

Levy is proud to have been the designer of the #10 wood screw, known as the Dual-Grip SLT, with its unique slotted tip and high low thread configuration. Under Levy's leadership, Ideal has continued to develop new and exciting products. With the help of a close manufacturing partner,

Ideal designed and began to market its Posi-Vent universal venting closure, allowing for a universal fit for several panel styles. A more recent addition is the EZ Grip. This fastener, specifically developed for plastic sheeting, has a winged design which opens a larger hole in the sheet to allow for the coefficient of expansion associated with plastic sheets.

Expect more to come. As Levy notes: "Ideal's commitment to the post and metal framing industry is indelibly written in the heritage and background of all its employees. We will continue this tradition to strengthen our success and ultimately the success of our valuable customers." **RB**

DEMAND THE BEST! SLT

"THE PROVEN PERFORMER"

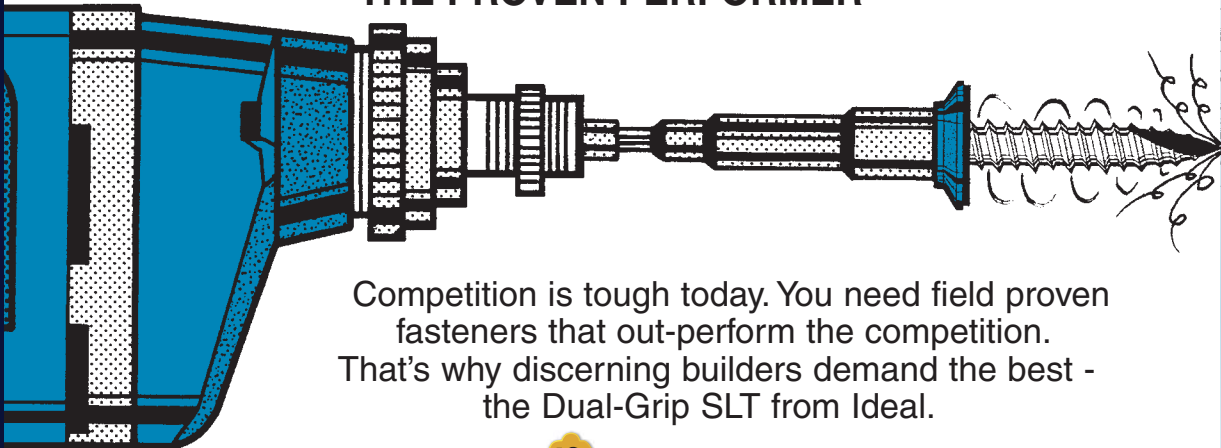

Competition is tough today. You need field proven fasteners that out-perform the competition. That's why discerning builders demand the best - the Dual-Grip SLT from Ideal.



- Lightning quick installation.
- Exclusive X-Tend coating for superior corrosion resistance.
- Color-Rite paint for an exact match every time.
- Also available Stainless Dual Grips for ACQ lumber.

It's More Than a Name - It's Our Attitude



920 Second Avenue
Coraopolis, PA 15108
(412) 299-6199 • (800) 670-5767
FAX (412) 299-6499
www.idealbuildingfasteners.com



KLAUER MANUFACTURING CO.

GOLD KEYS WON: 33

w: www.klauer.com **p:** 563.582.7201



■ Klauer Manufacturing Company is proud to receive the Gold Key of Excellence for the 33rd straight year, and is committed to continuing to provide quality products, excellent service, dependable delivery and competitive prices for years to come.

Klauer Manufacturing has been a trusted leader in the sheet metal building products industry since 1870. Located on the banks of the Mississippi River, in Dubuque, Iowa, Klauer is a family-owned business operated by fourth and fifth generation family members.

From its two locations in Dubuque, Klauer Manufacturing Company produces a wide variety of products servicing the residential, agricultural and commercial construction markets. Products are manufactured from steel and aluminum, both in mill, and with more than 150 pre-painted color finishes.

From roofing, rainware and siding, to metal building components, Klauer Manufacturing Company's products are of the highest quality available and distributed throughout the United States. **RB**



Aluminum Soffit System

- Featuring 16 popular metal building colors
- Precision engineered with more free air space for maximum energy saving ventilation.
- Easy installation for a complete and maintenance free soffit system.
- Complimenting fascia and trim accessories along with gutter products color matched for the complete soffit system.
- Durable and tough while still being a friend to the environment.
- Superior PPG TruForm 580 Paint System for a lifetime of performance in a wide spectrum of colors.
- A trusted name for supplying quality building products to the construction and remodeling industry for more than 140 years.



Quality since 1870



www.klauer.com 563-582-7201



PPG Coatings Protected

Made in the USA



MFM BUILDING PRODUCTS

GOLD KEYS WON: 1

w: www.mfmbp.com **p:** 800.882.7663

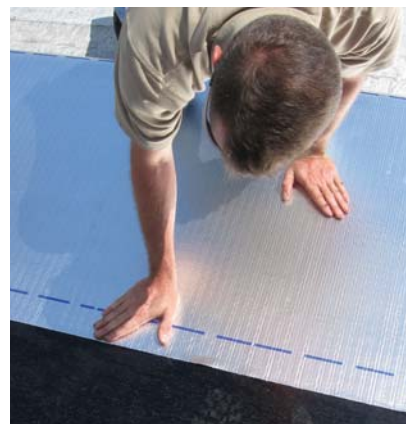

■ VERSATILE SELF-ADHERING WATERPROOFING MEMBRANE

Peel & Seal® from MFM Building Products is a self-adhering, 45 mil roll roofing specifically designed for low slope residential and commercial roofing applications. This single-ply membrane adheres direct to the roof deck and provides a long-lasting, durable, maintenance-free roofing surface.

Peel & Seal is so versatile that it can be used for whole roofs, flashing around exterior protrusions, gutter repair and any hard to waterproof area. The membrane is self-sealing around common fasteners to provide a watertight seal to prevent the infiltration of water. Peel & Seal can also be used on EPDM roofs when utilizing WeatherBond™ Primer.

The product is available in 3", 4", 6", 9", 12", 18" and 36" widths by 33.5-foot length rolls, and in four color options. Peel & Seal is tested to ASTM D 1970, meets ICC-ES AC75, Florida Building Code and is Miami-Dade County approved, Texas Department of Insurance Accepted RC38 and is UL® Classified.

Free product samples, technical literature, approvals, installation instructions and more are available. **RB**



Peel & Seal® is the original self-adhering waterproofing membrane designed for low slope roofing or flashing applications. This single-ply membrane applies directly to the roof deck and serves as the final roofing surface.

Ideal for hundreds of applications including whole roofs, dormers, sunrooms, metal roofs, and flashing around exterior penetrations.

- Ideal for difficult roofing applications
- Aggressively adheres to the roof deck
- Self-seals around fasteners
- Aluminized surface limits solar gain
- Easy handling and installation
- Requires no coatings or coverings for permanent exposure to sunlight
- Virtually maintenance-free
- Variety of widths and color options
- 10-year limited warranty
- Made in the USA



800-882-7663 | www.mfmbp.com

Circle Reader Service #412



MWI COMPONENTS

GOLD KEYS WON: 13

w: www.mwicomponents.com **p:** 800.360.6467



■ **MWI Components, honored with its 13th consecutive Gold Key of Excellence, would like to thank customers for their confidence and support.** MWI Components is celebrating 30 years of providing specialized metal products for the post-frame building industry. We will always pledge to provide quick delivery, excellent service and innovative products that make a customer's job easier.

MWI is a leading manufacturer of equine accessories, producing stalls, Dutch doors and sliding doors. With an in-house powder coat paint line, MWI offers three profiles of slide door rails painted quickly to

finish a building. Customers no longer have to settle for white doors or black stalls, MWI offers 30-plus colors of powder coat paint.

In late 2006, MWI purchased the slide door track and hardware division of Lawrence Hardware, the original creator of square track slide door systems. This enabled MWI to offer a complete selection of American-made round and square track and hardware for all industrial, post frame, farm and commercial buildings.

MWI Components is proud to introduce the newest addition to its track and hardware line. The Sabre Latch™ is a cost-effective sliding door latching system for

MWI's 3.5-inch door system. The exterior handles are sleek polished stainless steel and feature a dual keyed entry system. For exclusive use with the BC87, a heavy-duty, zinc plated Center Door Guide provides drive-over protection. Additional length of the BC87 Center Guide provides twice the amount of side wall engagement and lift retention as competitor's guides. The Sabre Latch™ system will keep your building safe while not sacrificing style.

We appreciate the customers who have supported MWI Components and we look forward to growing, along with our customers, in the future. **RB**



BUILT FOR POST FRAME

THE INDUSTRY'S LEADING MANUFACTURER OF SLIDING DOOR TRACK AND HARDWARE



Introducing the newest addition to our track and hardware line . . . **THE SABRE LATCH**®

- Exterior Lockable Polished Stainless Steel Handle
- Zinc plated Center Case with Inside Handle
- Quick Mount Bracket design installs within minutes to MWI 3300 Series Vertical Rail
- Interior latch functions even when the exterior handle is locked

BC87 - Center Door Guide

- Heavy ¼" thick Zinc Plated Steel construction provides drive over protection
- Acts as the receiver for the Sabre Latch®, ensuring a complete and secure coupling
- Universally mounts to a variety of applications



1015 32nd Ave West • Spencer, Iowa 51301

ph: 800-360-6467 • FAX: 800-361-3452

www.mwicomponents.com





MAC METAL

GOLD KEYS WON: 8

w: www.macmetalsales.com **p:** 800.887.5964



■ **Winning its eighth Gold Key of Excellence award is a great honor for MAC Metal.** The company is pleased to be recognized as one of the top companies in the industry and is thankful again to the dedicated customers that have made this happen.

Established in 1989, MAC Metal serves an eight-state region from its headquarters in South Central Kentucky, focusing on the post-frame commercial and residential markets.

MAC Metal provides 29 gauge Mac Rib pane, 26 gauge Hi-Rib panel and 26 gauge Mac-Loc panel.

The company's newest manufacturing facility is located in Brookville, Pennsylvania. Featuring a full line of trim and accessories in stock, this location gives MAC Metal even more flexibility

and a larger service area.

Quality service and satisfaction continues to be the goals this company keeps in focus as it serves its customers with dedicated delivery routes and the fastest order turn-around time in the industry. **RB**



Putting your job in motion.



Kentucky



Pennsylvania



1650 W. Hwy 80 Somerset, KY 42501 | Phone: 606.678.8331 Fax: 606.678.9691

84 Womeldorf Ln. Brookville, PA 15825 | Phone: 814.849.1966 Fax: 814.849.1968

Circle Reader Service #397



MCELROY METAL

GOLD KEYS WON: 33

w: www.mcelroymetal.com **p:** 800.562.3576



McElroy Metal voted as Gold Key Award winner for 33rd straight year

■ **McElroy Metal is proud to win the Gold Key Award for a 33rd consecutive year and appreciates the trust and loyalty of the readers of *Rural Builder* magazine.**

McElroy Metal has grown with and helped grow the post-frame industry over those 33 years and more, as an active member of the National Frame Building Association. That growth continues today, according to NFBA board chair Ken Gieseke, the VP of Marketing at McElroy Metal.

“The post-frame industry has evolved from shade and shelter agricultural buildings to long-lasting economical post-frame solutions for commercial and industrial buildings specified by architects,” Gieseke said. “Because McElroy Metal has been serving the architectural sector for decades, we have the products and know-how to help our post-frame customers grow with the possibilities of post frame.”

McElroy Metal believes in the versatility of post-frame construction. Post-frame construction saves money and time without sacrificing quality. That’s a part of what McElroy Metal is promoting every day. Gieseke said architects and consumers need to be educated on the benefits of post-frame construction in various applications, including low-rise commercial buildings.

“We appreciate the continued support and loyalty of customers who again considered McElroy Metal worthy of being a Gold Key Award winner,” said Ian McElroy, president of McElroy Metal. “It’s a real vote of confidence from our customers in the town and country market.”

ABOUT MCELROY METAL

Since 1963, McElroy Metal has served the construction industry with quality products and excellent customer service. The family-owned components manufacturer is headquartered in Bossier City, Louisiana, and has 12

manufacturing facilities across the United States. Quality, service and performance have been the cornerstones of McElroy Metal’s business philosophy and have contributed to the success of the company through the years. As a preferred service provider, these values will continue to be at the forefront of McElroy Metal’s model along with a strong focus on the customer. **RB**

Circle Reader Service Card # 422





METAL ROLLFORMING SYSTEMS

GOLD KEYS WON: 1

w: www.mrsrollform.com **p:** 888.284.6794



■ Metal Rollforming Systems is excited and honored to receive its first Gold Key award. MRS has been producing rollformers since 1993 and strives to create the best rollformer for our customers.

Metal Rollforming Systems aims to be your 'one stop shop' for all your rollforming needs, allowing our customers to save time and money when purchasing a rollformer. Along with our complete rollformer panel lines, we specialize in custom trim profiles along with all the needed accessories to complete your metal panel needs.

Our most recent rollformer design is our Patriot Rollforming Line. With its inte-

grated shear and modular die set, any number of profiles can be run on a single machine. This offers our customers flexibility for their production while costing less than our standard lines. The Patriot Line can also be reconstructed into a slit and recoil line, which is ideal for trim and snap-loc panel manufacturing.

We pride ourselves on our technical support for our customers. Our customers' success is our success. Our business is based largely on repeat customers and referrals, and we are honored that our customers speak so highly of us. We live under the philosophy that "service is the lifeblood of our organiza-

tion. Everything flows from it and is nourished by it. Customer service is not a department, it's an attitude." We strive to make the best experience for our customers and to make them confident they've purchased the right rollformer from the right company.

Metal Rollforming Systems has grown from a single man building rollformers to a 50-person crew. Our complete in-house design and production allows our team to keep precision control over each aspect of the manufacturing process. This assures us that each rollformer is done right and will be reliable for our customers for many years to come. **RB**



The Affordable Rollforming Equipment Manufacturer



Metal Rollforming Systems' complete manufacturing line includes:
Titan & Signature Rollforming Lines
Patriot Rollforming Line
Single & Multi-Trim Rollformers
Hemming Rollformers
Precision-Cut Slitting Lines
Upenders
Sheet Stackers
Ridge Cap Press
and much more!



4511 North Freya Street Spokane, WA 99217 888.284.6794 www.mrsrollform.com

Circle Reader Service #584



MILL STEEL

GOLD KEYS WON: 5

w: www.millsteel.com **p:** 800.247.6455



■ **Mill Steel Co., headquartered in Grand Rapids, Michigan, has been in business for more than 55 years and is committed to executing superior service with integrity.**

Operating on principles of reliability, accountability, and a people-first culture, Mill Steel has become one of North America's premier flat-rolled steel products distributors. Comprised of 12 production lines across processing locations in Grand Rapids and Melvindale (Detroit), Michigan; Birmingham, Alabama; and Jeffersonville, Indiana, Mill Steel guarantees quick turnarounds of pre-painted steel or bare steel for customized color match.

Last year Mill Steel announced the expansion of its operations to Jeffersonville, Indiana. The renovated 225,000-square-foot facility, located at the Port of Indiana-Jeffersonville, houses two state-of-the-art slitting lines, as well as a cut-to-length line. Mill Steel's wide distribution network, expert processing team, and outstand-

ing customer service align to meet demand in an ever-growing market, and to ensure that you get the best product, every time.

MILL STEEL OFFERS:

- Gold-standard Akzo 1050 and Valspar Weather XL cool chemistry systems, standard.
- Galvanized stock for supply to the steel stud trade as well as painted material for purlins.
- Dedicated metallurgists, engineers, and paint experts with decades of experience in painted building products, coating systems, substrates, grades, specialty processes, and processing.
- Extensive on-hand inventories of the colors you need precisely when you need them, and at prices that meet or beat market rates.
- A suite of hands-on services designed to make sure that your business runs with no hang-ups or interruptions. **RB**



A True Service Center.

In-house Service Capabilities
 Expansive Inventory
 Flexible Delivery
 Metallurgical and Paint Experts



Painted | Acrylic | Purlin

www.MillSteel.com | (800) 247-MILL (6455)

Follow us:





NOVAGARD SOLUTIONS

GOLD KEYS WON: 1

w: www.novagard.com **p:** 800.380.0138



■ **For the last 38 years, Novagard Solutions has been a leading manufacturer in the silicone sealant business.** Over the past five years, there has been a jump in the growth of a new product: Novaflex Metal Roof Sealant.

The Novaflex Metal Roof product is

formulated for easy application, especially in cold weather with extrusion temperatures ranging from -20°F to 120°F. It becomes tack free in 10-15 minutes and completely cured within 48 hours. The exclusive formula gives the sealant enhanced weather and UV resistance and this is one of the key

features of this product. This chemistry improves the long-term weatherability, flexibility and adhesion to a variety of substrates.

Novaflex Metal Roof Sealant is designed for sealing and bonding around wood, aluminum, metal, masonry, PVC and others substrates. Contractors have used this product successfully on flashing, trim, termination bars, lap joints, downspouts and gutters, in addition to metal roofs, buildings and panels. **RB**



Metal Roof Sealant

The flexible seal that lasts as long as the roof!

**Recipient of the
2015 Gold Key Of Excellence
Award**



www.novagard.com





PALRAM AMERICAS

GOLD KEYS WON: 13

w: www.PalramAmericas.com **p:** 800.999.9459 **fax:** 610.285.9928



■ **With more than 50 years of experience, Palram Americas, a leading manufacturer of Polycarbonate and PVC sheets, draws inspiration from market trends and customer requirements to create innovative solutions that are tailored to a variety of applications.** This constant innovation brings products and technology to the market that benefits the entire supply chain from the distributor to the end user.

Palram Americas takes pride in the cutting-edge solutions it has brought to the metal building industry. With energy costs rapidly rising, architects and engineers

are working harder to reduce the carbon footprint of their building designs. Natural daylighting options have become the standard in many guides and certification programs for energy reduction. Palram's proprietary MetalMatch™ technology allows the rapid creation of SUNSKY® polycarbonate panels to match virtually any existing metal profile. This technology is excellent for areas where electricity is not economically feasible (i.e. agricultural outbuildings), as well as in high-end projects that can benefit from the beauty of natural daylighting. Palram continues to help builders achieve maximum produc-

tivity and excellent job quality.

Other available products include AG-TUF™ and AG-TUF™ UV, the bright white PVC liner panels created for use in agricultural applications such as hog enclosures, dairy operations and much more. The liner panels have a high chemical resistance and are easy to install and clean with conventional methods.

Palram Americas is proud to receive another Gold Key of Excellence award and pledges to continue to provide customers with solutions that are creative, flexible, unique and competitive while continuing the highest standards of service. **RB**

**We can take any ribbing
and make light of it.**



Match virtually any custom profile with SunSky in days.

Get the leading corrugated polycarbonate delivered fast to fit most any metal profile with SunSky® MetalMatch™ technology. So you can add value and more daylight to projects in as little as two weeks. And MetalMatch is available at an extremely attractive price.



More daylighting options. More easily.

SunSky's first-in-class durability, high performance and superior light transmission are ideal for roof, side and skylight applications. So you can expand unique design possibilities, reduce energy costs, and enhance environments with more natural light. Available in several opacities,



including Soft White, SunSky is backed by a 10-year warranty. To learn more, contact your local distributor or call **800-999-9459**. Or visit us at www.PalramAmericas.com/MyProfile. We'll take the perfect ribbing and make it even better.



Circle Reader Service #350



RICHLAND LAMINATED COLUMNS LLC

8252 Greenwich, Ohio 44837

GOLD KEYS WON: 6

p: 419.895.0036 **fax:** 419.895.0062



Richland Laminated Columns has just completed its third major expansion in the company's short history.

Established in 2005, the company has added a nearly 19,000 square foot building at its headquarters in Greenwich, Ohio. Owner Elmer Sensenig said the post-frame building, set on Perma-Column posts, is currently being used as warehouse space, but long-term the plan is to convert it to manufacturing.

Richland manufactures its own Richland Laminated Column and is a franchise owner for Perma-Columns, manufacturing Perma-Columns for builders and lumberyards in Ohio and surrounding states. Call them to find your nearest distributor (wholesale only).

Richland Laminated has also expanded to 14 employees and has added its second delivery truck, this one equipped with a Moffett piggyback

lift for drop-site deliveries.

Sensenig started Richland Laminated Columns as a 19-year-old post-frame builder who had developed a simple yet effective product: a laminated column for post frame. He built post-frame buildings by day, and promoted his business by night.

Today, laminated columns are an industry standard and Richland Laminated Columns continues to offer post-frame builders an increasing range of post protection products. The company is what Sensenig and his crew has worked hard to become: "Your One Stop Pole Shop."

Sensenig maintains that "service, honesty and old-school values" are the cornerstones of his company, and adds, "We are very blessed. We give credit to the Good Lord, our dedicated employees and our expanding list of loyal customers for our continued success."

He wishes to thank everyone who voted for Richland Laminated Columns for the Gold Key of Excellence Award, its 6th consecutive. **RB**

Circle Reader Service Card #440



Richland Laminated Columns currently offers:

+ Distributor of Sturdi Wall and Sturdi Wall Plus Brackets, Post Protectors, The Footing Pad, and Concrete Post Pads

+ Manufacturer of quality laminated columns and Richland Perma-Columns

- 3-ply, 4-ply, 2x6, 2x8
- 100% treated or untreated
- Superior Treatment
- #1SYP Lumber
- 30% stronger than 6x6 solid



RIGIDPLY RAFTERS INC.

GOLD KEYS WON: 24

w: www.rigidply.com **p:** 717.866.6581



■ **It all began in the basement of Chester Shirk's home.** The year was 1954. Now 60-plus years later, Rigidply Rafters Inc. is still owned by the Shirk family.

Rigidply continues to manufacture metal-plated wood trusses and glue-laminated structural wood timbers and arches. Operating two facilities, located in Richland, Pennsylvania, and Oakland, Maryland, Rigidply has become one of the largest suppliers of post-frame building materials in the east.

The Rigidply Rafters' team continuously strives for excellence, and takes great pride in its unprecedented customer loyalty. It enjoys many customer relationships which have spanned over four decades, several generations and many bumps in the economy. Everyone at Rigidply Rafters remains fully committed to serving its customers and providing the finest products available. **RB**

AMONG THE **PRODUCTS** AVAILABLE FROM RIGIDPLY:

- 1.** The original and industry-best GluLam Post
- 2.** Roof and floor trusses
- 3.** GluLam beams and arches
- 4.** T&G lumber and decking
- 5.** Complete line of post-frame building materials
- 6.** Crane and engineering services

*Manufacturer of
Glue-Laminated Posts,
Beams, and Arches*



www.rigidply.com



**THE ONLY REAL LAMINATED POST
RIGIDPLY'S GLU-LAM POST**

Richland PA
Phone: (717) 866-6581
Fax: (717) 866-7237
Oakland MD
Phone: (301) 334-3977
Fax: (301) 334-9289

gold key awards



S-5!

GOLD KEYS WON: 2

w: www.S-5.com **p:** 888.825.3432



■ **S-5! is the international authority on metal roof accessory attachments.** Its innovative product designs have revolutionized the metal roofing industry with mounting solutions offering unmatched strength and longevity. S-5! produces extraordinarily versatile clamps and brackets that fit every major metal roof profile, including corrugated and trapezoidal.

S-5! VersaBracket and CorruBracket product lines allow just about anything to be easily mounted to exposed-fastened roofs, providing permanent

attachment of countless ancillary items, including signs/banners, walkways and HVAC, etc. The latest exposed-fastened bracket is the versatile ProteaBracket designed to fit trapezoidal sheet profiles with and without intermediate insulation. ProteaBracket features an adjustable attachment base and multiple solar module attachment options to accommodate varying widths and heights.

S-5! snow retention systems can be engineered on a site-specific basis, and are well-known for providing unrivaled holding strength while main-

taining the clean, colorful appearance of the roof. We also innovated the globally popular, UL listed S-5-PV Kit, a rail-free, DirectAttached mounting system for solar module installation on metal roofs.

S-5! products are installed on over 1.4 million roofs worldwide and trusted by engineers for critical holding strength, by architects for sleek design aesthetics, by roofers for zero-penetration technology, and by contractors for easy installation and reduced labor costs. **RB**

1.4 Million Roofs



Over 1,400,000 metal roofs around the world utilize S-5!® attachment solutions to mount ancillary items. Perhaps this is because S-5! clamps install faster and easier than any other attachment solution available on the market today. Or perhaps it's because our patented round-point, zero-penetration setscrews maintain the roof's integrity and preserve the panel manufacturer's warranty. We suspect it's because with holding strength measured in tons and dependability measured in decades, roofing professionals can't afford NOT to use S-5!

**1.4 million metal roofs and counting.
Always choose the best solution. Always choose S-5!**

To learn more about S-5!® products, go to:
www.S-5.com/millionRB or call 888-825-3432

Connect with us!

@S5_TheRightWay

/S5TheRightWay



S-5!
The Right Way!



SCHWEISS DOORS

GOLD KEYS WON: 5

w: www.schweissdoors.com p: 800.746.8273



Schweiss Doors announces new 20,000 sq. ft. factory expansion

■ Schweiss Doors, a leading manufacturer of Liftstrap Bifold Doors, powerful One-Piece Hydraulic Doors, and well known unique Designer Doors has constructed a new state-of-the-art factory electrical facility in Fairfax, Minnesota. The 80 x 250 foot building offers more than 20,000 square feet of assembly space for Schweiss engineering purposes. The electrical room is directly attached to Schweiss's existing warehouse and manufacturing plant, effectively centralizing all operations at the company headquarters under one roof for greater efficiency.

The new streamlined facility utilizes the space's close proximity to the sales and marketing teams. It has energy-saving in-floor heat,

overhead cranes, a 45 x 16 foot bifold entrance door, another 18 x 16 foot bifold door, along with a 16 x 16 foot fast-opening hydraulic side door. Utilizing a five overhead trolley system, it's easy to move hydraulic cylinders, new-style Red Power units and energy-saving liner/insulation packages throughout the electrical room.

Schweiss has rolled out a newly designed hydraulic "Build It Yourself" Door Kit. This cost-saving door kit is designed as a simple way for customers to build, weld and install their own hydraulic doorframe. Schweiss' new staging area provides enough room to assemble components necessary for each door kit that includes a complete set of new heavy-duty end and center hinges with grease zerks, cylinder plates, cylinders and rubber seals and more. It also leaves room to manufacture the Red Power hydraulic pump systems that go into each hydraulic door kit. For more information, visit <http://www.bifold.com/build-your-own-door.php> **RB**

New

One-Piece

800-746-8273

DOORS

- AG DOORS
- SHOP DOORS
- BARN DOORS
- AVIATION

2015
RB

Say YES... to Strap-Lift Doors

Say NO to Cable Lift

Get More for Your Money!

...Lift Straps

HYDRAULIC — OR — BIFOLD

"One-Piece" DOOR STRAP LIFT and auto latch

The Door Leader

SCHWEISSDOORS

.com

Circle Reader Service #414

WWW.RURALBUILDER.COM

67



SEALTITE BUILDING FASTENERS

GOLD KEYS WON: 9

W: www.sealtite.com P: 800.352.4864



■ Sealtite Building Fasteners is a leading supplier of threaded fasteners for the pre-engineered metal building and post-frame building industries. Product is shipped from two convenient service centers in Tyler, Texas and Cincinnati, Ohio.

The heart of the Sealtite product line is the MAXX STEELBINDER self-drilling screw. Its drill point design consistently penetrates high tensile steel with no "point walking."

The KWIKSEAL II WOODBINDER Type 17 post-frame screw has become an industry standard. The unique

thread design generates more holding strength in wood purlins, plywood and OSB than traditional #9 or #10 diameter screws.

A commitment to corrosion resistance is equally important to Sealtite. Zinc plating and chromate sealer is standard on all metal building and post-frame building screws. State-of-the-art POWDERFUL powder coating paint is an environment-friendly process that utilizes no chemical solvents and provides a tough barrier coat shell that is three times more corrosion resistant than traditional wet paint processes.

For metal roofs offering a 40 year or longer written warranty, Sealtite manufactures its ZXL product line. Steelbinder and Woodbinder ZAMAC 5 zinc aluminum alloy molded head drill screws and wood screws are an option for lifetime protection against red rust. The ZXL is quickly establishing itself as the next generation fastener for metal panels in 2015.

Sealtite would like to thank the readers of *Rural Builder* magazine for awarding it a Gold Key of Excellence award for 2015. Our commitment to quality products will never waver. **RB**

BORN IN FIRE

NOW IN 36 POWDERFUL™ COOL METAL COLORS

40 YEAR WARRANTY SEALTITE STRONG



ZXL WoodBinder®

The journey for all carbon steel fasteners begins in a heat treat furnace. However, it is the engineering excellence & functional, yet attractive design that separates the **ZXL WoodBinder** from competitive long-life screws.

- Head is molded for maximum pullover strength.
- KWIKSEAL® thread & point designed for today's high quality residential & commercial metal roof panels.
- Available with POWDERFUL™ powder coat paint system.
- EPDM rubber washer fits securely underneath the head.
- Written 40 year warranty against red rust on the head is available upon request.

No Red Rust



Molded ZAMAC 5 Zinc-Aluminum alloy provides maximum protection against red rust

CALL TODAY 800.352.4864





SNO GEM, INC.

GOLD KEYS WON: 4

w: www.snogem.com **p:** 888.SNO.GEMS (766.4367)



1" Curved **Sno Blockade™**
Snow Retention System

■ Sno Gem, Inc., would like to thank everyone whose vote of confidence led to a *Rural Builder* Gold Key of Excellence Award for the fourth consecutive year.

Sno Gem® is a company grounded in family pride, leveraging more than 100 years of combined experience in architectural sheet metal and roofing innovation. From the original polycarbonate snow guard that launched the Sno Gem® name in 1994, to the latest iClad™ and Sno Blockade™ snow retention systems, the company continues to provide new options in snow guard solutions. Both the iClad™ (fence/rail) and Sno Blockade™ (bar) systems utilize our new Sno Cube™ clamps with patent-pending WaveLock™ Technology ensuring a secure system.

We hope to continue to earn your trust in the years to come as we strive to engineer additional safety options for standing seam metal roofing in our belief that "Snow Should Only Fall Once™." **RB**



info@snogem.com
888-SNO-GEMS | snogem.com

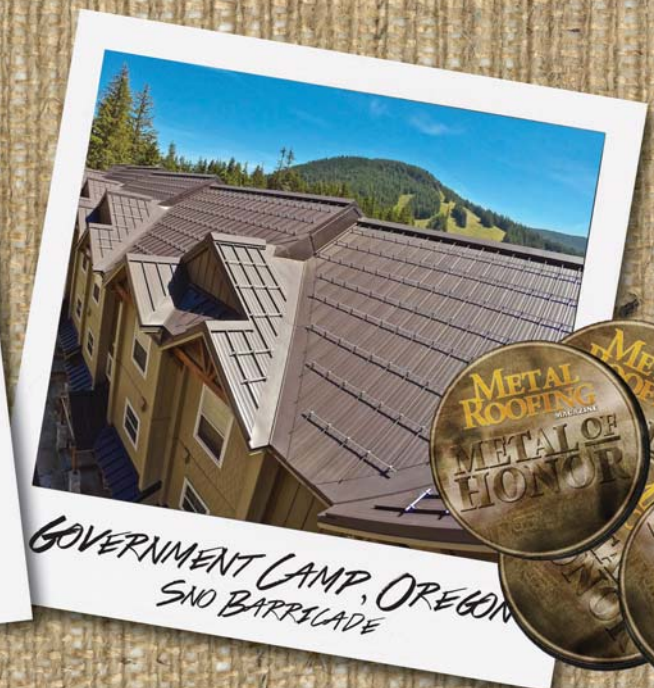
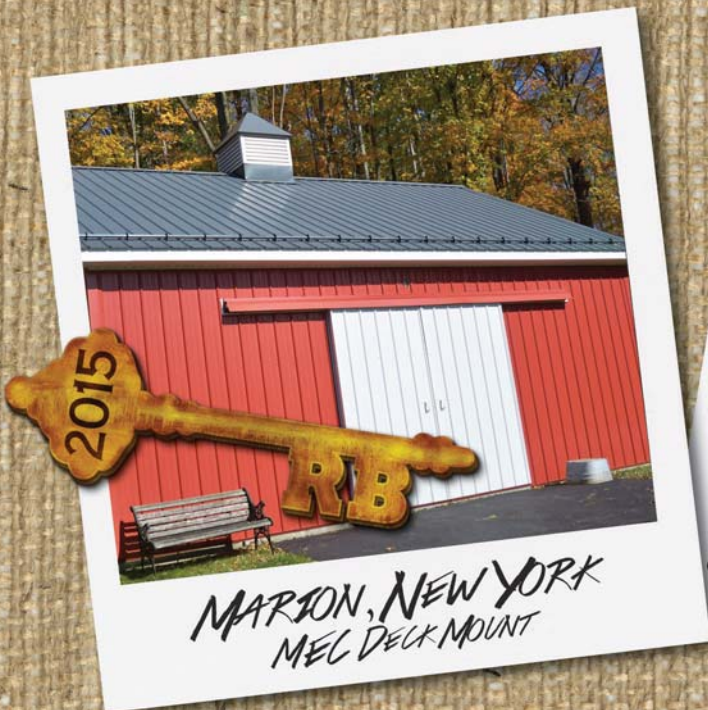



SNOBAR

GOLD KEYS WON: 3

w: www.sno-bar.com **p:** 800.711.9724



■ **What separates SNOBAR from other snow retention manufacturers?** SNOBAR does not sell products to be installed on the MOST roofs or measure success by the number of jobs sold; it sells products to be the best system installed on the owner's roof.

There is a reason why SNOBAR offers a free "lifetime" warranty on material and performance, it is not because the company sells the most products, it is because they take care of one customer at a time. SNOBAR designs each and every project sold. They take the time to determine what the customer needs.

This is one of the reasons the company has so few distributors, personal attention and hands-on approach to each customer's needs. Having too many distributors equals fighting over that sale. This could lead to the owner getting an improper design and a possible system failure.

SNOBAR offers systems for standing seam metal roofs, exposed fastened roofs, membrane/TPO roofs and shingle roofs. All these systems are offered in non-corrosive, stainless steel or can be painted to match just about any color on today's market.

SNOBAR has been around for more than 20 years with millions of lineal feet in place and that's the reason they stand behind their products with a lifetime materials and performance warranty.

Most of the competition has to use multiple clamping devices to attach their systems to standing seam roofs. With SNOBAR's systems, its distributors only have to carry a few clamps that work on 95 percent of the standing seam roofs on today's market.

Want to corral snow up on your roof? Then check out SNOBAR's full line of snow management products. **RB**

TAKE OUR FREE AIA COURSE @www.SnowRetention101.com



OFFERING THE ULTIMATE IN SNOW RETENTION FOR CORRUGATED, SHINGLE, MEMBRANE AND STANDING SEAM METAL ROOFS



Patented

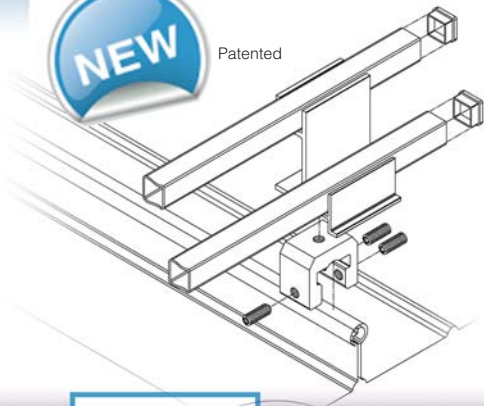

NEW 2 BAR SYSTEM



LARGE COLORBRACKET SYSTEM

NEW 2 BAR SNOW RETENTION SYSTEM

- WILL FIT MOST STANDING SEAM ROOF PANELS
- WORKS WITH COLORBAR OR CAN BE PAINTED TO MATCH



SCAN THE QR CODE OR VISIT THE WEBSITE TO SEE MORE DETAILS @ www.SNOBAR.com



SNOBLOX-SNOJAX

GOLD KEYS WON: 5

W: www.snojax.com P: 800.SNOJAX-1



■ We would like to thank the readers of *Rural Builder* magazine for awarding SnoBlox-Snojax our 5th consecutive Gold Key of Excellence award. Our core commitment to providing premium snow retention products and world class customer service is the key to our success and this award reassures us that we're on the right track!

We have seen some very intense winters lately with record breaking snow and ice accumulations. These harsh winters put snow retention to the test and SnoBlox-Snojax systems withstand anything Mother Nature throws our way.

The late Jack McMullen and his son Brion started the Snojax company 39 years ago with the idea to make an imperceptible snow guard that would last the life of the roof. Snojax patented the world's first polycarbonate snow guard in 1976. Today, SnoBlox-Snojax carries an extensive line of the best snow retention products and is a select distributor for the world's first seam-mounted SnoBar system patented in 1992. Our company is ranked among the industry's highest in customer service.

Our wide selection of snow guard and bar system styles allow us to provide our

customers with the best snow retention systems based on their project-specific requirements. Our recent warehouse expansion allows us to ship in-stock products the same day. "Our customers deserve fast turn-around times and the highest quality products. We strive to meet these expectations every day! All of our products are made exclusively in the USA and we back what we sell for the life of the roof," says Brion McMullen.

Your project's success starts with a visit to www.SpacingTool.com and our free AIA CEU accredited training course at www.SnowRetention101.com. **RB**

Take Our Free AIA Course at www.SnowRetention101.com



Lifetime Warranty Included With All Designed Snow Retention Systems!



Polycarbonate & Stainless Snow Guards



www.Snojax.com

SnoBar • ColorBar • ColorRail



www.SnoBarColorBar.com

SS Ventsaver Kits 12-16 & 12-24



www.VentSaver.com

www.SnoBlox.com

Call 1-800-SNOJAX-1

www.SpacingTool.com

Circle Reader Service #417



STARWOOD RAFTERS

GOLD KEYS WON: 10

w: www.starwoodrafters.com **p:** 888.525.5878



Starwood Rafters was founded in 1964 as a manufacturer of laminated arch rafters and beams. Starting out in Independence, Wisconsin, it was a three-man operation, with the original owners, Joseph Wozney and his two partners working nights after working at their regular jobs. They shipped mainly to Wisconsin, Minnesota, Iowa and the Dakotas.

In the early 1970s, they developed the Lam-Ply Truss, combining plywood, glulams and dimensional lumber to make a truss that is stronger than a conventional web truss. This allows the builder to

space them farther apart to reduce erection time and labor costs. This design also limits bird nesting and improves ventilation in livestock facilities.

The Lam-Ply Truss can span up to 80 feet and is used in many applications, from machinery storage, to livestock facilities, to horse arenas, to park shelters. It also has been developed with a gambrel-style and a mono-slope design. All Starwood products are custom-designed to meet customers' specifications.

Today Joseph's sons, Corey Wozney and Steve Wozney, and his son-in-law, Randy Sluga, operate the company. Still

STARWOOD RAFTERS PRODUCES:

- Lam-Ply Truss
- Gambrel Lam-Ply Truss
- Mono Lam-Ply Truss
- I-Lam Beam
- Laminated gothic arches
- Timber and specialty trusses made to customers' designs

in Independence, Wisconsin, Starwood Rafters now ships products anywhere in the U.S. Starwood Rafters' biggest asset is its ability to be flexible to meet its customers' needs. There is no job too big or too small. **RB**



LAM-PLY TRUSS

The Truss That Will Carry The Load

- Spans up to 72 ft.
- Spacings up to 12 ft. on center, depending on the load you desire
- Bird Nesting Control
- Better Ventilation & Visibility
- No Feed Alley Post Obstruction
- Additional Ceiling Height



Starwood Rafter Uses

- Pole Sheds
- Free Stalls
- Pavillion Shelters
- Machinery Storage
- Riding Arenas
- Solar Barns



W24141 Starwood Lane
Independence, WI 54747
(715) 985-3117 • 888-525-5878

www.starwoodrafters.com

Circle Reader Service #375



SWENSON SHEAR

GOLD KEYS WON: 11

w: www.swensonshear.com **p:** 877.588.8748



■ For more than 55 years Swenson Shear has manufactured innovative tools to ease the difficulty, improve the quality, and speed the process of metal panel preparation and installation.

Swenson Shear now offers the Snap Table line of products, providing two all-in-one options to notch, slit, and hem all standing seam panels.

The Snap Table HD adjusts to accommodate between 12 inch and 22 inch panels, and is equipped to notch, slit, and hem up to 33 inch offsets for hips and valleys.

The Snap Table PRO is the newest addition to the line, added to provide the capability to slit and hem up to 60 inch for any commercial, industrial, or residential job site.

Swenson Shear has spent the last year revamping all product lines in order to continue to provide the highest quality metal panel preparation for concealed and exposed fastener panels, soffit and siding, and stone coated steel. **RB**



INTRODUCING THE ALL NEW SNAPTABLE HD COLLECTION



SNAPTABLE HD & PRO

- The Snap Table is an all-in-one panel/roofing system for standing seam metal roofing; with the highest quality in notching, slitting and hemming
- Consistently notches, slits & hems standing seam profiles from 12"-22"
- Saves an average of 35% labor cost.
- 2 Year Manufacturer's Warranty
- 33" or 60" slitting and hemming capabilities
- Proudly designed and manufactured in the USA



IDEAL FOR: Lite guage to Cor Ten 1", 1 1/2" Nail Strip, 1", 1 1/2", 1 3/4" SnapLock, 1", 1 1/2", 2" Mechanical Seam, ZipRib and many more options.



Looking for more information from companies featured in this issue?

Use the Reader Service card facing this page to get **FREE** information from our advertisers!

Free online info at www.bit.ly/info-rbfn

ADVERTISERS

| RS # | Company | Page # |
|------|---|------------|
| 334 | A J Manufacturing, Inc. | 44 |
| 291 | AB Martin | 45 |
| 310 | ABC Supply Company | 12, 13 |
| 317 | Alpine Snowguards | 82 |
| 441 | Aztec Washer Co. | 87 |
| 338 | Becker Specialty Corp. | 46 |
| 435 | Bradbury Group, The | 14, 15 |
| 386 | Cannonball:HNP, LLC | 16, 17 |
| 383 | Central States Mfg. | 47 |
| | Clark Industries | 90 |
| 358 | DBCI | 48 |
| | Doorbrim | 89 |
| 530 | Direct Metals, Inc. | 49 |
| 581 | Dura Coat | 18, 19 |
| 316 | Dynamic Fastener | 20, 21 |
| 498 | East Coast Fasteners | 10 |
| 364 | Edco Products, Inc. | 50 |
| 407 | Everlast Roofing, Inc. | 22, 23 |
| | Extrutech Plastics | 89 |
| | FARMTEK | 89 |
| 507 | Fasteners Direct, LLC | 51 |
| 488 | Firestone Building Products | 52 |
| 433 | Graber Post Buildings | 24, 25 |
| 295 | H & H Metal Products | 53 |
| 520 | Hydroswing North America | 92 |
| 380 | Ideal Building Fasteners | 54 |
| | Integrity Metals | 89 |
| 563 | Irwin Industrial Tool Co. | 2 |
| 302 | Klauer Manufacturing | 55 |
| 341 | Leland Industries | 26, 27 |
| 392 | Levi's Building Components | 28, 29, 89 |
| 331 | METALCON | 91 |
| 412 | MFM Building Products Corp. | 56 |
| 308 | MWI Components | 57 |
| 397 | Mac Metal Sales, Inc. | 58 |
| | Marion Manufacturing | 90 |
| 306 | Maze Nails Company | 30, 31 |
| 422 | McElroy Metal, Inc. | 59 |
| 584 | Metal Rollforming Systems | 60, 89 |
| 415 | Mill Steel Co. | 61 |
| 378 | National Frame Building Assn. | 75, 81 |
| 463 | Nationwide Protective Coating Mfrs., Inc. | 4 |

| RS # | Company | Page # |
|------|-----------------------------|--------|
| 387 | Northstar Metals Mfg., Co. | 34, 35 |
| 290 | Novagard Solutions | 62 |
| 421 | PMC Industries | 5 |
| | Paint Valley Parts, LTD | 89 |
| 350 | Palram Americas | 63 |
| 485 | Petersen Aluminum Corp. | 8 |
| 313 | Plyco Corporation | 36, 37 |
| | Power Lift Hydraulic Doors | 89 |
| | Replications Unlimited | 89 |
| 440 | Richland Laminated Columns | 64 |
| 382 | Rigidply Rafters | 65 |
| 408 | Ritchie Industries | 7 |
| 450 | S-5! | 66 |
| 414 | Schweiss Doors | 67, 89 |
| 429 | Sealtite Building Fasteners | 68 |
| | Semmler Systems, Inc. | 90 |
| 482 | Sno Gem, Inc. | 69 |
| 589 | SnoBar | 70 |
| 417 | SnoBlox/SnoJax | 71 |
| 540 | Spectrum Brands HHI | 32, 33 |
| 375 | Starwood Rafters, Inc. | 72 |

| RS # | Company | Page # |
|------|-----------------------------|--------|
| 462 | Steel Dynamics, Inc. | 38, 39 |
| 345 | Sukup Manufacturing | 40, 41 |
| 472 | Swenson Shear | 73 |
| 425 | Triangle Fastener Corp. | 76 |
| 301 | VP Buildings, Inc. | 77 |
| 484 | Valspar Corporation | 42, 43 |
| 374 | Western Products of Indiana | 78 |
| 511 | Wick Buildings | 79 |

STORY RESOURCES

| RS # | Company | Page # |
|---------------------|---------|--------|
| NEW PRODUCTS | | |

| | | |
|-----|-----------|----|
| 110 | GoPet LLC | 74 |
|-----|-----------|----|

PRODUCT PROFILE: INSULATION

| | | |
|-----|--------------------|----|
| 111 | A.J. Manufacturing | 80 |
| 112 | Covertch | 80 |
| 113 | MWI Components | 80 |
| 114 | Plyco Corporation | 82 |
| 115 | Thermal Design | 82 |

new products



■ DOORS FOR DOGS

The pet industry is exploding and more contractors are involved with buildings for dog-related businesses. So where do you go when you need a doggy door? GoPet LLC (Raytec Manufacturing), has responded to demand with the development of the Dog Vue Door.

The door is designed so that even short-nosed breeds like English Bull Dogs can easily use it. The clear see-through door provides light and is attractive and inviting to dogs as compared to more dark opaque doors or torn vinyl flaps. An

optional training system feature helps the most skeptic dog feel comfortable. Doors are framed in aluminum and were tested for over one million cycles.

For more information circle 110.

The most comprehensive guide for building with post frame



- Eight brand-new chapters
- More than 200 pages
- Hundreds of photos, diagrams, and design tables

Visit www.nfba.org to order your copy now.

NFBA
NATIONAL FRAME BUILDING ASSOCIATION

www.nfba.org

Circle Reader Service #378



TRIANGLE FASTENER CORP.

GOLD KEYS WON: 9

w: www.trianglefastener.com

p: 800.486.1832



We have standard fasteners, tools sealants, and accessories

...and much more!



We offer the largest selection of specialty products for the roofing industry. Our proprietary and patented products are designed for superior performance and fast installation.

When you need more...Call TRIANGLE FASTENER

800.486.1832



Visit our website for the most up-to-date product information
www.trianglefastener.com



Triangle Fastener Corporation provides standard and specialty fasteners, tools, sealants, and accessories for roofing industry from 23 locations. Additionally, we offer job-site support, custom painted screws, rivets and metal closure, and we can help you select the correct fastener for your application.

We design our fasteners for ease of installation and long-life.

PANEL-TITE® METAL-TO-WOOD SCREWS

Fasten metal panels, trim, or flashings to wood substrates. Choose from #9, #10, #12, and #14 diameters in lengths up to 3 inches long. Panel-Tite comes standard with our TRI-SEAL® 1,000-hour salt spray coating on all of our carbon steel screws. For extra long-life applications, we offer a 304 stainless steel or a 304 stainless steel cap head Panel-Tite.

CONCEALOR® PANCAKE HEAD SCREWS

We have the largest selection of sizes in the roofing industry. Select from #10, #12, #14, and 1/4-inch diameters and lengths up to 9 inches long for attaching clips over rigid insulation. Concealor comes with a square recess for optimal driving stability, and many sizes are long-life coated with our Tri-Seal coating for use in treated lumber.

BLAZER® WITH VRT® BACK-OUT RESISTANT THREAD

For fastening metal roof laps and trim, we offer our patented back-out resistant thread, VRT Technology. The VRT (Vibration Resistant Thread) keeps the fastener tighter in applications where expansion, contraction, and vibration are a concern. Independent tests verify that VRT produces over 2-1/2 times more back-out resistance than a standard thread. **RB**

Circle Reader Service #425



VARCO PRUDEN BUILDINGS

GOLD KEYS WON: 4

w: www.vp.com p: 901.748.8000



■ **Varco Pruden Buildings is a division of BlueScope Buildings North America, Inc.** Through advanced engineering and proprietary systems and building products, Varco Pruden (VP) provides innovative steel building solutions worldwide for low-rise commercial and industrial applications, including offices, warehouses, schools, manufacturing and retail projects.

VP products have been recognized and approved by U.S. Army Corps of Engineers, Underwriters Laboratories, Energy Star, Cool Roof Ratings Council, Quasar (Canada), Miami-Dade County Commission and Factory Mutual. Headquartered in Memphis, Tenn., the company markets its products through a network of more than 1,000 authorized builders within the United States and Canada. VP has affiliations in Europe, Asia and South America and is a member of the Canadian Sheet Steel Building Institute, the U.S. Green Building Council and a founding member of the Metal Building Manufacturers Association.

Varco Pruden Buildings - Building Solutions....One relationship at a time. **RB**

The building suppliers you can trust focus on

BUILDING STRONG RELATIONSHIPS.



The most solid foundation upon which to build a partnership is trust. That's why, for more than 60 years, Varco Pruden has focused on creating relationships that last. Our interest is always your best interest. While we offer decades of experience and expertise, constantly educating ourselves on your environment and consumers, we also take pride in our loyalty and value our credibility. You can depend on us to work for you. Because we're not just reliable, we're dedicated. And we never compete against our builder partners.

We offer superior products and service, including:

- ◆ Unrivaled quality
- ◆ Cutting-edge technology and innovation
- ◆ Unequaled marketing tools and resources
- ◆ A wide array of products
- ◆ Experienced project management and field support

Contact Varco Pruden today. Let us show you how, together, we can add value to your business and your reputation.



Visit www.VP.com/ad/RB GK to receive this free brochure "Built on a Tradition of Excellence."



WESTERN PRODUCTS

GOLD KEYS WON: 8

w: www.westernproductsinc.com **p:** 800.553.5142



■ Whether you use box track or round track, you'll find the strength, shape and size you desire in door tracks, hangers, trolleys, brackets, sliding door accessories, door frames and horse stalls from Western Products.

Choose from Western's box track options of 400 pound to 1,000 pound capacity, or its round track at 600 pound capacity. Discover the convenience of Western's complete product line.

Western is known for its customer service and customer loyalty. Most of its track orders are shipped from inventory within three to five business days.

Quality, service and pricing are important to this family-owned and operated company and has been since 1929.

A lot has changed since then, but not its commitment to service its customers.

Call Western Products today, and build a future together. **RB**



BOX and ROUND TRACK

HORSE STALLS and ACCESSORIES

1-1/2" + 3-1/2" SLIDING ALUMINUM DOOR FRAMES

YOU'RE ON THE RIGHT TRACK WITH WESTERN™

ROUND TRACK

Best Price & Best Product in the Industry!

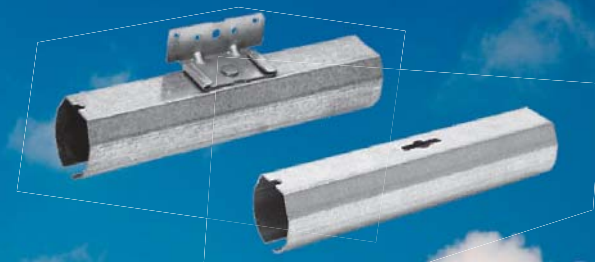

Call us with your requirements today. We'll help you build the future.

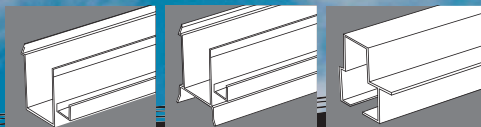

ALSO FROM WESTERN: 1 1/2" + 3 1/2" SLIDING ALUMINUM DOOR FRAMES

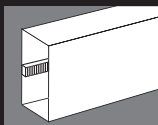

(800) 553-5142

www.westernproductsinc.com

WESTERN™
PRODUCTS OF INDIANA



WICK BUILDINGS

GOLD KEYS WON: 31

w: www.wickbuildings.com **p:** 800.356.9682



■ Wick Buildings provides custom designed and engineered buildings through a network of independent builders for agricultural, commercial, suburban and equine use. With more than 71,000 buildings constructed over the past 61 years, Wick Buildings knows what it takes to create a building that will stand the test of time — and all that Mother Nature cares to send its way.

Flexible design. One of Wick Buildings' biggest advantages is design flexibility both outside and inside. In addition to large clear-span capability of 100 feet in width, Wick's engineered wood-frame buildings can incorporate interior build-outs and the addition of wings and leans to provide additional space.

Energy efficiency. Energy efficiency is a hallmark of Wick Buildings. Many wall and roof steel "cool colors" can be selected with sun reflectivity in mind to reduce roof temperatures up to 100 degrees Fahrenheit. With several ceiling insulation options and insulated flush wall configurations, interiors are cozy, draft-free and ready for interior build-out.

Customization. Wick works with independent builders to customize each design around the needs of the buyer and local building codes. Wick Buildings' design staff can customize the design and provide engineer-stamped plans for code approvals.

High quality materials. High tensile steel (82,000 PSI) on the exterior is the starting point to ensure durability and impact resistance against hail and wind-blown objects. A G-90 zinc coating is applied for excellent corrosion resistance and finished with Ceram-a-Star 1050 Paint System for long-lasting beauty. Under that durable skin is a structure with all structural components utilizing Machine Stress Rated (MSR) or Machine Evaluated Lumber (MEL) — to make sure each Wick building will stand the test of time! **RB**

Exceptional Value and Service

Wick Buildings has been helping Midwest farmers, families and businesses by providing long-lasting, low-maintenance buildings since 1954!

Buildings with quality and value... and no compromises. Join our team!

800-356-9682

WickBuildings.com



**Wick
Buildings®**

Agriculture ■ Suburban ■ Equestrian ■ Commercial

Like us on



Circle Reader Service #511

INSULATION

1. A.J. MANUFACTURING / CIRCLE 111

A. J. Manufacturing is a distributor of Low-E reflective insulation, the only polyethylene foam on the market. It is waterproof, insect resistant and bird resistant. When a screw is run through the microfoam it is sealed by the hundreds of micro cells offering extra protection from roof leaks. The closed cell foam has superior PSI rating to support roof panels over purlins. It is Class A/Class 1 fire rated in foil over foil and with white face! The white face is still foil and won't flake when exposed to UV light. Low-E foam insulation is flame adhered, not glued, in a patented process. ESP Low-E reflective insulation meets the requirements of NFPA 286.

2. COVERTECH / CIRCLE 112

rFoil reflective insulation patent technology material from Covertech is a single or double layer of polyethylene bubbles boned to and sandwiched between a radiant barrier metalized foil and white polyethylene sheet. rFoil is specifically designed to control heat gain/loss and prevent condensation in all types of metal-clad and post-frame

buildings. rFoil is a Class1/Class A fire rated product and passes the NFBA 286 full corner burn test.

3. MWI COMPONENTS / CIRCLE 113

MWI Components offers a safe, easy-to-use thermal insulating material that provides cost-effective, high-efficiency performance for a wide range of applications. TempShield is a technologically advanced insulation material ideal for new construction or retrofit installation in residential, commercial, industrial, metal buildings and post-frame buildings. It consists of one or two layers of



07 /

JULY

16-18, Florida Roofing & Sheet Metal Expo, Orlando; floridarooft.com

09 /

SEPTEMBER

2-5, National Association of Women in Construction Annual Meeting and Conference, Nashville. nawic.org

30-Oct. 1, "Introduction to Structural Design of Wood Buildings" course, per 2015 NDSVT. Sponsors: American Wood Council, Virginia Building Code Officials Assn. and Virginia Tech University. cpe.vt.edu

10 /

OCTOBER

1-2, 2015 Remodeling Show & Deck Expo, Chicago; remodelingdeck.com

14-16, METALCON 2015, Tampa, Fla. metalcon.com

20-23, Building Component Manufacturers Conference, Milwaukee. bcmcshow.com

11 /

NOVEMBER

18-20, Greenbuild, Washington, D.C. greenbuildexpo.com

Participate in NFBA's New Safety Recognition Program



With more post-frame contractors being inspected by the Occupational Safety and Health Administration each month, every company needs the foundation of an established safety program. Having a solid and compliant safety program will get you off on the right foot in any OSHA inspection.

NFBA's new safety program, the Gail Miller Recognition Program for Excellence in Safety, was established in honor of Gail Miller, a committed building professional devoted to the post-frame industry and the safety of its workers.

How does the program work?

1. Fill out an application form, answering questions that address essential components of your company's safety program. (Separate forms are available for builder companies and supplier companies.)
2. A trained committee grades your application. NFBA's legal and safety counsel oversees the committee's work and grading process. (All applications are graded anonymously. The only person able to identify an application with a particular company is the NFBA's legal counsel.)
3. Receive your grade and a confidential comprehensive report from NFBA's legal and safety counsel. The report provides valuable and detailed feedback on your company's existing safety program.
4. All participating companies receive a certificate of participation, and those achieving platinum, gold, silver, or bronze status will be recognized at the 2016 Frame Building Expo awards luncheon.
5. All expo attendees from a participating company receive a ribbon recognizing the company's award level to attach to their name badge.

Is my company eligible to participate?

The program is open to all NFBA members, both builders and suppliers. Not a member? Go to www.nfba.org, call 800.557.6957, or write to NFBA, 8735 W. Higgins Rd., Chicago, IL 60631.

How does the program provide value to my company?

The program shows your employees that you take their safety seriously and shows your customers that you are committed to job-site safety.

You receive expert feedback on your existing safety program. Companies pay hundreds—even thousands—of dollars for this level of expert review! As an NFBA member, you receive this service for a nominal entry fee.

2014 Gail Miller Recognition Program for Excellence in Safety

- A. J. Manufacturing—**Silver**
- American Building Components—**Gold**
- Atlas Bolt and Screw—**Gold**
- Central States Manufacturing—**Gold**
- FBi Buildings—**Gold**
- McElroy Metal Inc.—**Silver**
- Quality Structures—**Silver**
- Tailored Building Systems—**Silver**
- Wick Buildings—**Gold**

product profile

BY RURAL BUILDER STAFF

Barrier Bubble air cellular material laminated between layers of aluminum foil to provide excellent thermal resistance. Offered is a Class A/Class 1 fire rating on white poly/foil insulation. It's available in standard widths of 48 inches and special order widths up to 120 inches.

4. PLYCO CORPORATION / CIRCLE 114

Ply-Foil is a multi layer, reflective insulation from Plyco, which comes in rolls consisting of a variety of widths and lengths for use in both specialty and standard construction projects. Two outer layers of aluminum foil reflect 97 percent of the radiant heat. Each layer of foil is bonded to a tough layer of polyethylene for strength. The inner layers of bubble pack resist conductive heat flow while a center layer of polyethylene gives Ply-Foil additional strength. Ply-Foil provides nominal 3/16-inch thick Single Bubble, nominal 5/16-inch thick Double

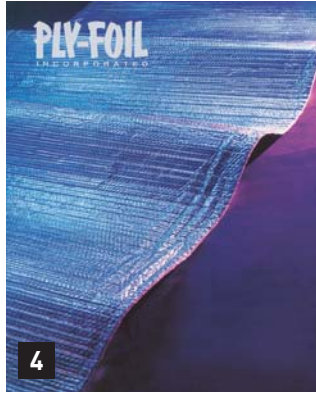

Bubble, Standard Edge and Staple Tab product lines for both metal and post-frame construction. Perfect for new construction or retrofit.

5. THERMAL DESIGN INC. / CIRCLE 115

Thermal Design's Simple Saver System is a high performance insulation and finishing system designed for roofs and walls in non-residential buildings

(new/retrofit). It is customized to fit each bay with a single continuous piece of flexible fabric liner and supported by a variety of strap options to help yield the designed insulation values with minimal insulation compression. Once installed, the Simple Saver System provides an instant and economical interior finish with exceptional acoustics and enhanced light reflectivity.

An advertisement for Alpine Snowguards. The background is a photograph of a snow-covered metal roof on a building. A red wooden cupola with a weather vane is mounted on the roof. The text is overlaid on the left side of the image.

 **ALPINE
SNOWGUARDS®**

Prevent a roof avalanche...
Keep snow in its place

Snow guards for every roof type

- Custom solutions
- Cost-effective
- Rugged

www.alpinesnowguards.com

Circle Reader Service #317



Sauter's new CLT building houses a new Hundegger jointery machine he can use for his existing timber-frame business as well as cross-laminated timber. Sauter photos

On the front line of emerging CLT market

U.S. timber supplier positions for a future in cross-laminated timber



Reinhard Sauter

CROSS-LAMINATED TIMBER HAS YET TO MAKE A BIG SPLASH IN THE U.S.

market, but some forward-thinking pioneers are not standing on the sidelines waiting for the needle to move. They're jumping in and showing people what CLT offers.

One of those pioneers is Reinhard Sauter, owner of Sauter Timber in Rockwood, Tennessee. Sauter has built his own award-winning CLT building, which he uses in his manufacturing business.

Earlier this year, Sauter's building won a national award for commercial wood design from WoodWorks, an initiative of the Wood Products Council. He uses the new building to house a new machine that will help him to continue cutting timber-frame packages, but also now allows him the opportunity to cut CLT for what he considers is an emerging market in the U.S.

"We see a big market in CLT coming up in the next few years," he said. He sees one of the big stumbling blocks cur-

rently in the U.S. market is the lack of machines like his that will cut all the CLT for prefabricated packages, ready for installation. The CLT itself can be sourced from several suppliers in Europe and Canada, or new companies moving into that territory here in the U.S.

A native of Germany, Sauter has long been familiar with CLT. It is a popular building material in Europe, where it is used for homes, businesses, and even multi-level structures. When he began to hear rumblings here in the U.S., he decided to learn more.

"I heard a little about the bell tower in Gastonia, North Carolina, that's when it was first used in the United States. Then I thought a little about investigating," he said, adding: "I went to a CLT symposium four years ago in Canada and said, ok that's the way to go."

Sauter said he needed a new machine anyway for his timber frame business and decided to buy a machine that could handle the job for that as well as CLT. His choice of a German-made

project feature

BY SHARON THATCHER

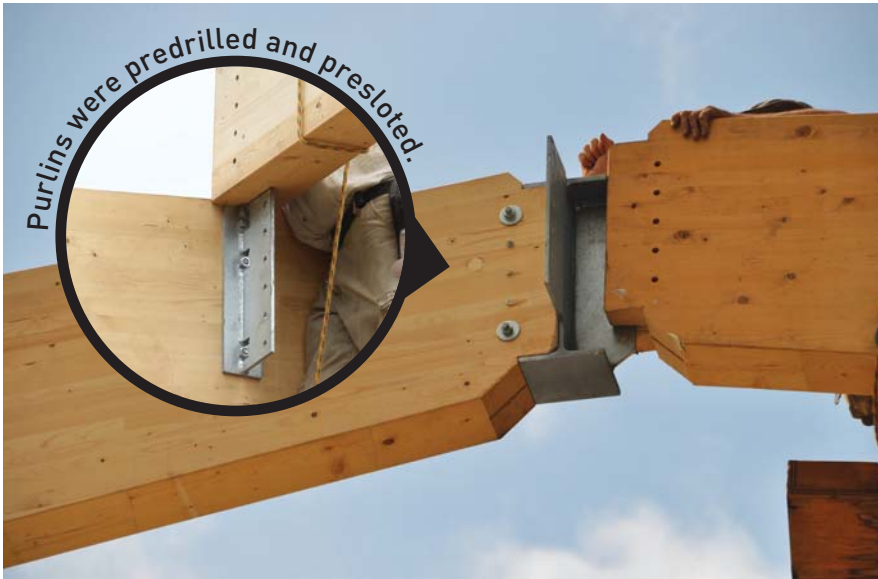

The first truss was assembled partially in the air. Sauter photos



Inside the new building soon after completion. Sauter photo



Hundegger ROBOT-Drive, was a good reason for building a new structure to house it. He also wanted a CLT building to show prospective customers and his former metal building couldn't do that.

"We wanted to show something was possible," Sauter explained. "We used to be in the log home industry and customers would say, 'O.k., you sell me a log home, so, where do you live, in a log home, too?' and I would say, 'No, I live in a stick-frame home.' 'Oh,' they would say, 'why do you sell me a log home when you don't live in one?' I don't want such a question. We're in the wood business, we

should use wood," he said.

Because Sauter didn't have his new machine yet, his CLT was purchased over seas. "We had everything pre-cut, pre-labeled in Austria and shipped in containers. Then we raised it up," he said.

There is a learning curve when working with CLT, he noted, but it is not difficult and only a few relatively inexpensive tools are needed for installation. "You have to know how to hang it on the crane, how to store it, how to support. It's not spectacular, but [a worker should not do it] himself the first time. To understand that procedure, you have

to do it once or twice or three times, then away you go."

CLT is often drywalled and sided, but can be left exposed and like any exposed wood, needs to be sealed. Making sure it is plumb is also critical. "You have to size things really plumb. It's like, if you put tiles up, you put the first one up plumb, then it's easy game."

Sauter Timber is preparing to make CLT available the same as it currently does for timber-frame packages. "We usually buy square timber, rough sawn. We cut it and mill it and label it for how the job site needs it. We also handle



The building takes shape with each section, or bend, in place, ready for CLT wall installation. Walls were installed in pre-cut panels, five high. Sauter photo

details: here's the outlet, here's the joint, here's how many screws are needed, here is where you put them. That's our part," Sauter said.

His company has morphed with the demands of time, starting with log homes, then panelized packages and then timber frame. His sights are now set for a higher end market, which he believes will be first to embrace it.

Price-wise, CLT is comparable to timber frame. "I think the price is about the same as timber frame," he said. "Timber frame is very labor intensive but you have a character, you have an

aesthetic that you don't have with CLT, which is structural.

"With stick frame you can't compete, but with steel and concrete we're very competitive on the commercial side."

In Europe, where CLT originated in the 1990s, use of the product has been growing about 25 percent a year in the past four or five years. There it is commonly used for one or two-story multifamily and single-family homes. It is being used for limited multi-story buildings as well, but Sauter sees a more promising future for low-rise. Although he is not against high-rise CLT, he believes it is

best for builders to focus on what is more attainable. He compares it to racing cars. "You can want to be a race car driver, but it's probably not the best advice to start with a Formula One car," he said.

And while the U.S. market for CLT is still on trainer wheels, Sauter believes the product is too good to be hidden for long. "Slowly it comes," he said. "Slowly, but for sure it will." **RB**



More photos online at
RuralBuilder.com

Window selection and installation

Help your customers get the most out of product performance

THE MOST IMPORTANT FACTORS OF WINDOW PERFORMANCE IS CHOOSING THE PROPER TYPE OF WINDOW AND PROPER INSTALLATION. These choices are all part of good design. To have the best performance, the designer must incorporate a whole building concept for humidity control, ventilation, overall performance, etc. The correct window selection and proper installation will affect the overall performance of a building.

▶ Window Selection and Code Considerations

Window components include the outer frame and the sash, which includes the glazing and a spacer forming a sealed unit. Typical frames include wood, PVC, aluminum/Thermal-Break aluminum, clad wood (aluminum or PVC) and composites such as wood fiber and fiberglass.

Window products are built to meet industry standards. These are consensus-based engineering standards intended to reduce the potential for confusion between local and regional codes, commercial building codes, architectural specifications, design drawings and the installation instructions. Due to these industry standards, all window materials are tested on a level playing field.

Selection is primarily based on the exposure to wind, temperature difference and moisture levels. The life of the window and its performance will depend a great deal on the amount of moisture exposure. Ventilation of the building is very important and must be considered in order to control humidity levels.

The wind force on the window will vary depending on many factors. The ICC-Codes provide a method to arrive at the wind forces. In addition, selection takes into account that the combination of rain and wind can force water around the seals, between sash and frame, weep holes and pin holes.

Windows are tested and given a rating in order to guide the selection of the proper window. Performance testing requirements are per AAMA/WDMA/CSA 101/I.S.2/A440 NAFS-1 – North American Fenestration Standard (NAFS). This test standard is cited in the ICC-Codes.

The air-water-structural (AWS) ratings assigned to the window per NAFS take into account the air resistance, water resistance, operation force and the

structural wind load resistance. Air leakage is tested in the lab and limited to 0.30 cfm/sq. ft. Water resistance is similarly tested using a calibrated air pressure differential to simulate wind loads. Water coming through the screens and around overlapping weatherstrip is taken to the exterior by the internal drainage system in the window.

Thermal performance is also tested and rated per National Fenestration Ratings Council (NFRC) standards. The model building codes, IBC, RBC and IECC—requires NAFS and NFRC certified rating and labeling of typical pre-manufactured window units. NFRC certifies for the residential and commercial codes, and is the only means to enter the Energy Star program.

Understanding what can be expected of the window in terms of air, water, structural and thermal performance is also important to the installer. He must balance exposure to wind and importance of the protection against window cost and installation technique and time. The higher the rating on the window commonly means the most investment in the installation is required for the type of exposure for which the window is rated.

Commercial building codes include several sections affecting the installation of the windows. Section 1405.4 of the 2012 IBC requires window openings to be flashed in such a manner as to prevent moisture from entering the wall or to redirect it to the exterior.

Section 703.8 of the 2012 IRC requires that self-adhered membranes used as flashing are to extend to the surface of the exterior wall finish or to the water-resistive barrier for subsequent drainage. The sealing methods between dissimilar materials must allow for differential expansion and contraction. Where required by the code official, an approved third party shall inspect all components and verify compliance.

To write specifications, you may cite ASTM E 2266 - Standard Guide for Design and Construction of Low-Rise Frame Building Wall Systems to Resist Water Intrusion, which is not a code requirement, but it takes you to back to ANSI/AAMA/WDMA 101/I.S.2/A-440 North American Fenestration Standard (NAFS), and to ASTM 2112 Standard Practice for Installation of Exterior Windows, Doors and Skylights.



Al Geisthardt is engineering manager for product development at Plyco Corporation, and a 2014 inductee in the Rural Builder Hall of Fame. He will be conducting a workshop at the 2016 Frame Building Expo in Indianapolis. For Expo updates check www.nfba.org.



Pay-Offs

Maintaining customer satisfaction pays off in many ways, including staying within the boundaries of the warranty.

► Window Installation

These guidelines and standards have this objective: Install the products properly and seal them to the building air barrier, maintaining the water drainage plane as intended.

Window opening framing is basic. The header and the vertical framing next to the window opening normally support the window. The sill forms the bottom of the rough opening and supports the siding installed on the lower portion of the wall.

The procedural objective is always to identify the weather barrier. The weather barrier can be one of two types: 1) Membrane/Drainage system, or 2) Surface Barrier System, meaning: a sealed drainage plane.

The **Membrane/Drainage System** also uses the exterior surface to shed water along with a “Weather Resistant Barrier” (WRB), commonly called *house wrap*. This diverts water penetration to predetermined exit points at the base of a building or base of wall-to-roof intersection. The WRB must be installed in overlapping fashion. The construction sequence is very important. Know who is responsible, and coordinate the installation with inspection. Proper selection of the WRB is critical, along with proper selection of the details and type of window to provide humidity control. Sketch out the flashing and/or sill pan and how to integrate with the WRB on any records kept for the project.

The **Surface Barrier System** utilizes the outermost surface along with a flashing technique. This is the typical strategy for steel siding and is considered a sealed drainage plane.

Manufacturer’s instructions should be considered the *minimum* requirement, and should be considered a requirement, not an option. The installer may find conditions which are not covered, so consult with all appropriate parties. When confusion arises you may require a written waiver from the manufacturer. Proceed, but obtain full documentation and keep it in the files a minimum of 10 years.

Shims are required for installation. Avoid twisting the frame material. Flat shims made from high-impact plastic, stackable in 1/16-inch increments are preferred.

“Setting” shims/support blocks are placed within 3-inches of the ends. Some windows may require shims to be installed at the center of the sill permanently. Do not shim at the center of header to prevent binding caused by settlement.

“Lateral” shims are used on the sides of the frame to square the window. If there is an anchor point near the shim, the shim must remain in place. Any temporary shims may be removed after nailing the mounting flange.

Flashing, in terms of window installation, is a waterproof sheet material. The purpose is to prevent water penetration into the wall cavity. Most wall leaks are due to a lack of flashing, or deterioration of sealants. Types of flashings include: mechanically attached flexible, and self-adhering flexible.

Mounting-flange windows are generally used with the “Membrane/Drainage System” and are designed to be attached with fasteners. Always provide blocking between horizontal girts/nailers for a continuous backer at the mounting flange. Integral mounting flanges are continuous and waterproof.

Applied nailing flanges require sealant—follow manufacturer’s instructions.

► ASTM E2112 Window Installation Practice

ASTM 2112 is the first broadly recognized standard for installation of windows, doors and skylights. This practice is commonly cited in manufacturer’s specifications and instructions. There are four methods described based on flashing/WRB sequencing, but it is not in a format that can be used on a job site.

The principles of the ASTM 2112 Installation Practice are applicable to post-frame. It provides minimum requirements, and does not limit or exclude new procedures. But, it does not cover all cases, and excludes asbestos or lead hazards.

The steps to properly flash the window to house wrap or sheathing are critical. Flashing is installed in overlapped “weather-board” fashion. The sill is first, and is overlapped by the sides, and sides are overlapped by the top. Flashing is protected from the wind and sun as soon as possible, and any damaged flashing must be replaced before covering. Fastener holes should be minimized, and any incorrect holes, tears, etc., must be resealed.

Sill pan flashing may be used between the rough framing and the window and has an interior upright leg – back dam. Sill



Aztec Washer Company

Master Flash®

EMC
Retrofit Installation



20
YEAR
WARRANTY

Res Flash
Residential Installation



20
YEAR
WARRANTY

The Only 20 Year,

CSA & UPC

Approved Flashings

of their Kind!



PH: (858) - 513-4350
www.aztecwasher.com

Circle Reader Service #441

pan flashing is recommended for all windows but is not mandatory. When provided, it should slope outward and drainage must go directly to the exterior. It must be used with specific flashing, and must be sealed to inhibit air infiltration.

If using no house wrap or sheathing, use the exterior steel cladding as a Surface Barrier System. Use a self-adhering flashing at the sill, sides and header, or use a pan flashing system. Seal trim to the nailing flanges by use of bedding sealant. Seal the trim to the perimeter of the window unit if there is no nailing flange. Avoid any area where water weeping in-between the steel and the inside wall can be trapped by keeping cuts simple. Allow water to weep through the bottom of trim junctions.

Sealants are used to prevent the infiltration of air and water around joints and should contribute to the appearance. Use the sealant proper for the two materials being joined. You may be sealing next to steel, brick, wood siding or EIFS (Exterior Insulation and Finish System) and 100 percent silicone rubber sealant provides excellent durability, flexibility and adhesion.

Unless otherwise specified, a minimum of 1/4-inch wide sealant bond to each surface is necessary to ensure adequate adhesion (for example, PVC to steel siding). For mechanically fixed joints with little or no movement, use no less than 1/8-inch to each surface, thus all caulk beads are 1/4-inch or greater for adhesion and proper sealing.

The installer and supervisor are ultimately responsible for the quality of the work, although the architect/engineer are often the "approving authority" and can make specific decisions that affect the installation. Always communicate with all

those who may be affected, and keep records of all discussions and decisions.

The most important factor affecting window performance is choosing the proper type of window for the application. These choices are all a part of good design. To provide the best service, the designer must incorporate a whole building concept for humidity control. Understanding what can be expected of the windows chosen will affect the design of the ventilation of a building and cannot be ignored.

► The benefits of proper installation

Good performance of the windows in a building brings many benefits to your customer. Maintaining customer satisfaction pays off in many ways, including staying within the boundaries of the product warranty.

Application of the proper windows for the intended purpose will promote consistent high quality installations, installer safety, improved specification writing and improved energy efficiency. These important benefits will lead to lowering costs, improving credibility through knowledge, and improving the image of your building company.

A company policy may include a section on the method used to select, install and service windows. This policy may be based on a requirement to follow the recommendations and manufacturer's instructions included with the window. In addition, you might want to include a window selection and installation section in your building specifications. **RB**

people in the news



EURAMAX NORTH AMERICA ANNOUNCES THE RETURN OF SCOTT BACON AS THE VICE PRESIDENT OF COMMERCIAL SALES FOR FABRAL.

Bacon returns to Fabral after spending four years as the Business Unit Director for Centria's MetalWrap. He previously served Fabral as the Vice President, Director of Sales from 2000 to 2011. He has more than 29 years of experience in the building products industry, demonstrating in-depth knowledge of the architectural and post-frame markets.

Bacon's new responsibilities include sales and business development execution and customer acquisition and development.



THE BRADBURY COMPANY HAS APPOINTED BEN BIGHAM TO MECHANICAL ENGINEERING MANAGER.

Employed with Bradbury since 1999, Bigham previously held the position of Project Engineering Manager. In his new role he will be responsible for all aspects of mechanical and hydraulic engineering.

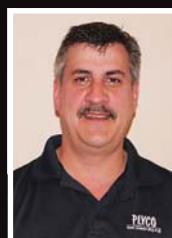

PLYCO CORPORATION HAS NAMED A NEW MARKETING MANAGER.

Kyler Pope, with more than 20 years of marketing and sales experience, will be responsible for managing and implementing marketing initiatives for both Plyco and East Coast Fasteners

120 BUILDING COMPONENTS



INTEGRITY METALS

We manufacture quality metal roofing and wall systems.

- Product line offering Integrity Loc, 16" Standing Seam, 26 Gauge PBR Panel
- 40 year Painted Galvalume
- 10 year Polyester

Lancaster, KY, 1-800-417-1176
www.integritymetals.org

160 DOORS & WINDOWS

New One-Piece DOORS 800-746-8273

AG DOORS
SHOP DOORS
BARN DOORS
AVIATION

Say YES... to Strap-Lift Doors
Say NO to Cable Lift

HYDRAULIC — OR — BIFOLD
 "One-Piece" DOOR STRAP LIFT and auto latch

SCHWEISSDOORS.com

Doors built for a lifetime.

- Every Door Built, Delivered and Installed by Local Professionals
- Lifetime Structure Warranty
- Safe, Strong & Weathertight
- Zero Maintenance
- No Lost Headroom
- New or Existing Buildings



POWERLIFT

HYDRAULIC DOORS™

855-368-9595 www.powerliftdoors.com

DOORBRIM Awnings



DOORBRIM Door Canopies are an economical solution for protecting doors, windows and hardware from Mother Nature. A front gutter diverts water to keep doorways dry while preventing leaks, rust and decay. DOORBRIM Door Canopies can be easily installed in minutes. Proudly made in the USA.

Currently Seeking Dealers Nationwide
DOORBRIM.COM (754) 400-1357

175 HELP WANTED



BUILDING INSTALLERS WANTED

Rapidly growing fabric building manufacturer looking for installers experienced in steel construction. Must be insured, have existing crew, tools and the ability to make equipment and travel arrangements.

Jen Simon 563.875.2288 x788
jsimon@esapco.com



Seeking Texas Sales Rep

Growing National Building Components Company seeking effective representation in the region covering the state of Texas. Firm/Individual must have experience in building products, including metal roofing components; have established contacts in this product area and the desire to grow this market.

Levi's is a wholesaler of quality snow guards, fasteners and building materials for the metal roof industry and pole barn construction.

Contact Chris Ray, National Sales Manager
877-897-7020
 or email at chris@levisbuildingcomponents.com

LEVI'S BUILDING COMPONENTS
 137 Newport Rd., Leola, PA 17540
www.levisbuildingcomponents.com

250 MISCELLANEOUS



INNOVATIVE STONE WAINSCOT PANEL SYSTEM

www.urestonepanels.com

NEWS & SPECIAL FEATURES
www.RuralBuilder.com

250 MISCELLANEOUS

Extrutech FORM™ System



Extrutech FORM™ System brings a bright new 6" thick by 24" inch wide face to stay-in-place concrete form construction by combining standard concrete form methods with the easy-to-clean, sanitary surface that Extrutech panels provide. Perfect for process area walls.

Suspended Ceiling Panels and Doors also Available

NEW PRODUCT

888-818-0118
www.epiplastics.com
 email: info@epiplastics.com

Manufacturing American-Made PVC Panels for 22 Years!

EXTRUTECH PLASTICS, INC.

400 ROLL FORMERS



Acu-Form

ROLL FORMING EQUIPMENT

Manufacturer of metal forming equipment, for commercial and residential construction use.

We use D2 tool steel as a standard.

Phone (330) 674-4003 Fax (330) 674-4035



MRS

METAL ROLLFORMING SYSTEMS

The Affordable Rollforming Equipment Manufacturer

- Single & Double Deck Rollformers
- Trim Rollformers
- *NEW* Patriot Rollforming Line
- Coil Reels
- Precision Cut Slitting Lines
- Sheet Stackers
- Coil Upenders
- Ridge-Cap Press



1.888.284.6794 www.mrsrollform.com

classified ads

CALL 800-726-9966

600 TOOLS/EQUIPMENT DISTRIBUTOR



MARION MANUFACTURING

- Automation Systems
- Metal Construction Rollformers
- Coil Processing
- Forming & Fabrication
- Recondition Existing Machines

WE ADD THE VALUE TO METAL

1-888-865-8740 www.marionmanufacturing.com

Make Your Own Nail-Lam Column



BIG RED III
Total Fabricating System

Ph: 605-787-4765
Email: jimsemmler1@msn.com
www.semmlerinc.com

Your One Stop Shop



Clark Industries, Inc.
Since 1967 - Monett, Missouri



Considering equipment?
Consider Clark.

- Roof & Floor Truss Presses
- Multi-Head Truss Presses
- Modular Truss Presses
- Shuttle Presses
- Jack Presses
- H.D. Chord Splicers
- Post & Column Machines
- Floor Truss Machines
- Electric Horizontal Stackers
- Electric Peak-up Stackers
- Conveyor Systems
- Custom Machinery

Call us toll free at: 800.743.9727
or visit us on the web at: www.clark-ind.com

supplier news

■ Perma-Column Updates *Design and Use Guide*

Over the past few years, codes, wood values, and column sizes have evolved significantly. All these changes are now incorporated into a new *Perma-Column Design and Use Guide* authored by Brent Leatherman P.E. and Dimitry Reznik, P.E. of Timber Tech Engineering, Inc.

The updated guide is intended to be used by post-frame building engineers and designers as a companion document to the test results document for Perma-Column by David R. Bohnhoff Ph.D.

The new *Perma-Column Design and Use Guide* includes code updated from the American Concrete Institute (ACI), The American Institute of Steel Construction (AISC), and National Design Specification for Wood Construction (NDS).

It can be downloaded from www.permacolumn.com or requested by e-mail at sales@permacolumn.com.

■ Timber Technologies achieves AITC Certification

Timber Technologies LLC has achieved certification by the American Institute of Timber Construction (AITC).

Status as a certified, licensed organization, means Timber Technologies LLC has met nationally recognized standards for the provision of ANSI/AITC A190. For 60 years, the American Institute of Timber Construction has been the national technical trade association of the structural glued laminated timber industry.



▲ Haddock receives Swaney Award

S-5! founder and CEO Rob Haddock (center) was named by the Metal Construction Association (MCA) as this year's recipient of the prestigious Larry A. Swaney Award. The award honors an individual in metal construction who selflessly fosters the growth and betterment of the industry. Haddock began his career as a metal building erector before founding S-5! and became a sought-after metal roofing consultant, inventor (he holds more than 30 patents), speaker and author. He serves as an adjunct faculty member at the University of Wisconsin School of Engineering and is the director of the Metal Roof Advisory Group, Ltd. He has been a Lifetime Honorary Member and advocate of MCA since 1985. Haddock is pictured with Bill Croucher (left), the 2005 Swaney Award winner, and Dick Bus (right), the 2011 recipient.

TAMPA, FLORIDA USA
October 14-16, 2015

25th

METALCON

Learn. Network. Explore.



Best Practices in Metal Technology

Peer-to-Peer Education Sessions

Business Tactics for Success

Innovative Metal Products & Services

Hands-on Metal Roofing Challenges

A Powerful 3 Days Well Spent!

www.metalcon.com



RSMJ | Resources, Inc.

The One Event for Metal Construction Products, Technologies & Solutions. | METALCON

Circle Reader Service #331

HYDROSwing®

Hydraulic Doors & Walls



Simple, Strong, Secure!

Hydroswing® ...the Ultimate Hydraulic Door System



Hydroswing® is a trademark™ "If it's not from Hydroswing® it's not a Hydroswing®"

Call us 800 404 4937 • Visit us www.hydroswing.com

Circle Reader Service #520